

AREA STATEMENT		VERSION NO: 18/01/2024	
PROJECT DETAIL			
Authority: Jhansi Development Authority	Plot Use: Residential		
Authority Class: Category D	Plot Sub Use: Plotted Res development / Plotted Housing		
Authority Grade: Development Authority (DA)	Development Plan: Master Plan		
Case Track: Regular	Land Use Zone: Residential Use Zone		
Project Type: Layout Development	Land Sub Use Zone: Residential Zone		
Nature of Development: NEW	Development Area: Undeveloped Area		
Development Area: Undeveloped Area	Layout Type: NA		
Sub Development Area: Other Town Area			
Special Project: NA			
Site Address: District: Jhansi, Tehsil: Jhansi, Village: Pali Pahari			
AREA DETAILS		Sq.Mts.	
1. Area of Plot As per record			
Document Area	2456.00		
Area as per site condition	2261.81		
Area of Plot Considered	2261.81		
2. Deduction for			
a) Proposed roads	0.00		
b) Dry reservations	0.00		
c) Total	0.00		
3. Net Area of plot (1 - 2) AREA OF PLOT	2261.81		
Plot Area For Coverage	2261.81		
Plot Area For FAR	2261.81		
Perm. FAR Area (1)	0.00		
Total Perm. FAR area	0.00		
8. Total Built up area permissible at			
Permissible Coverage area (%)	0.00		
Proposed Coverage Area (%)	0.00		
Total Prop. Coverage Area (%)	0.00		
Balance coverage area (%)	0.00		
Proposed Area at:			
Total Area	Proposed Built up	Existing Built up	Proposed FAR
	0.00	0.00	0.00
Total FAR Area:			0.00
Total Built up Area:			0.00
C: Tenement Statement			
4: Tenement Proposed At:			



MASTER Plan



SARZA Plan

Color Notes

COLOR INDEX

ABUTTING ROAD	Black
PROPOSED CONSTRUCTION	Green
COMMON PLOT	Yellow
ROAD ALIGNMENT (ROAD WIDENING AREA)	Orange
FUTURE T.P. SCHEME DEDUCTION AREA	Blue
EXISTING (To be retained)	Light Blue
EXISTING (To be demolished)	Dark Blue

Proposed Population Calculation

Plot Name	Use	Sub Use	Range	No.	Perm. Person/Plot	Perm. Person/Unit	Total Person/Plot	Total
12	Residential	Row House		2	10		20	
01	Residential	Row House		2	10		20	
02	Residential	Row House		2	10		20	
11	Residential	Row House		2	10		20	
03	Residential	Row House		2	10		20	
10	Residential	Row House	above 50 upto 150sq.mt.	12	5		60	120
14	Residential	Row House		2	10		20	
09	Residential	Row House		2	10		20	
05	Residential	Row House		2	10		20	
08	Residential	Row House		2	10		20	
07	Residential	Row House		2	10		20	
06	Residential	Row House		2	10		20	
Grand Total:								120

Number of EWS/LIG unit required

SI No.	Plot Type	No. of Plot	No. of unit in one plot	Total Number of units	Proposed LIG/EWS Unit
1.	Single Dwelling Unit	12	1	12	-
Total :		12		12	-
Number of EWS/LIG unit required (10% LIG)					
Total :				2.00	0
Number of EWS/LIG unit required (10% EWS)					
Total :				2.00	0

Tenements Density Check

Net housing density	No. Of Tenements		No. Of Persons	
	Reqd	Prop	Reqd	Prop
750/hec.	34	24	170	120

Land use analysis/Area distribution (Table 2c)

Area covered under	Proposed Area in sq. mt.	Percentage(%)
Plotted Area	1469.85	64.99
Road Area	791.96	35.01
Total net layout	2261.81	100.00

OWNER'S NAME AND SIGNATURE
 M/S SHIV VARDAN REAL ESTATE PARTNERS ARUN KUMAR PANDEY & SURESH KUMAR PREMCHANDANI,
 0015pandey@gmail.com, 9453877404

ARCHITECT'S NAME AND SIGNATURE
 SHUBHAM GUPTA
 AM17558775062019

Jhansi Development Authority

Building Plan Application Number
 JDALD/23-24/0581

Sanctioned On
 13 Feb 2024

Valid Till
 04 Mar 2029

Approved By
 Alok Yadav (Vice Chairman)

Examined By
 Vinet Kumar (Junior engineer)

Jhendra Singh Sahrawar (Town Planner)

Upma Pandey (Secretary)

Alok Yadav (Vice Chairman)

Upma Pandey (Secretary)

Alok Yadav (Vice Chairman)

Individual Plot Setback

Plot No.	Plot Area	Front	Side1	Side2	Rear	Coverage	FAR	FAR Area	
								Prop	Perm
01	12.00 MT WIDE MAINROAD	2.00	-	-	-	2.00	0.00	0.00	0.00
02	12.00 MT WIDE MAINROAD	2.00	-	-	-	2.00	0.00	0.00	0.00
03	12.00 MT WIDE MAINROAD	2.00	-	-	-	2.00	0.00	0.00	0.00
04	12.00 MT WIDE MAINROAD	2.00	-	-	-	2.00	0.00	0.00	0.00
05	12.00 MT WIDE MAINROAD	2.00	-	-	-	2.00	0.00	0.00	0.00
06	9.00 m.wide Internal Road	2.00	-	-	-	2.00	0.00	0.00	0.00
07	9.00 m.wide Internal Road	2.00	-	-	-	2.00	0.00	0.00	0.00
08	9.00 m.wide Internal Road	2.00	-	-	-	2.00	0.00	0.00	0.00
09	9.00 m.wide Internal Road	2.00	-	-	-	2.00	0.00	0.00	0.00
10	9.00 m.wide Internal Road	2.00	-	-	-	2.00	0.00	0.00	0.00
11	9.00 m.wide Internal Road	2.00	-	-	-	2.00	0.00	0.00	0.00
12	9.00 m.wide Internal Road	2.00	-	-	-	2.00	0.00	0.00	0.00

Individual Plot Area

Plot No.	Abutting Road	Plot Area	Frontage		Coverage		FAR Area		
			Reqd	Prop	Factor	Perm	Prop	Perm	
01	12.00 MT WIDE MAINROAD	40.00	-	142.43	3.50	9.50	0.00	0.00	0.00
02	12.00 MT WIDE MAINROAD	40.00	-	112.50	3.50	7.50	0.00	0.00	0.00
03	12.00 MT WIDE MAINROAD	40.00	-	112.50	3.50	7.50	0.00	0.00	0.00
04	12.00 MT WIDE MAINROAD	40.00	-	112.50	3.50	7.50	0.00	0.00	0.00
05	12.00 MT WIDE MAINROAD	40.00	-	112.50	3.50	7.50	0.00	0.00	0.00
06	9.00 m.wide Internal Road	40.00	-	142.50	3.50	9.50	0.00	0.00	0.00
07	9.00 m.wide Internal Road	40.00	-	142.50	3.50	24.50	0.00	0.00	0.00
08	9.00 m.wide Internal Road	40.00	-	112.50	3.50	7.50	0.00	0.00	0.00
09	9.00 m.wide Internal Road	40.00	-	112.50	3.50	7.50	0.00	0.00	0.00
10	9.00 m.wide Internal Road	40.00	-	112.50	3.50	7.50	0.00	0.00	0.00
11	9.00 m.wide Internal Road	40.00	-	112.50	3.50	7.50	0.00	0.00	0.00
12	9.00 m.wide Internal Road	40.00	-	142.43	3.50	9.50	0.00	0.00	0.00

Total Plot Area :- 2261.81
 Total FAR Area :- 0.00
 Total Coverage Area :- 0.00
 Total BUA Area :- 0.00



LAYOUT PLAN (Scale - 1:100)

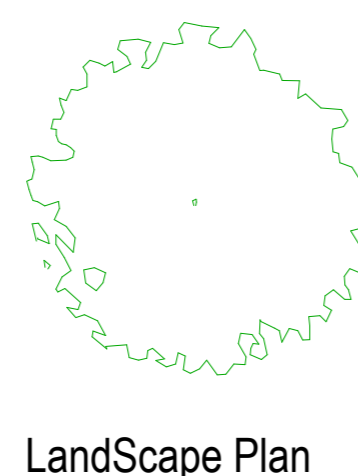

Landscape Plan

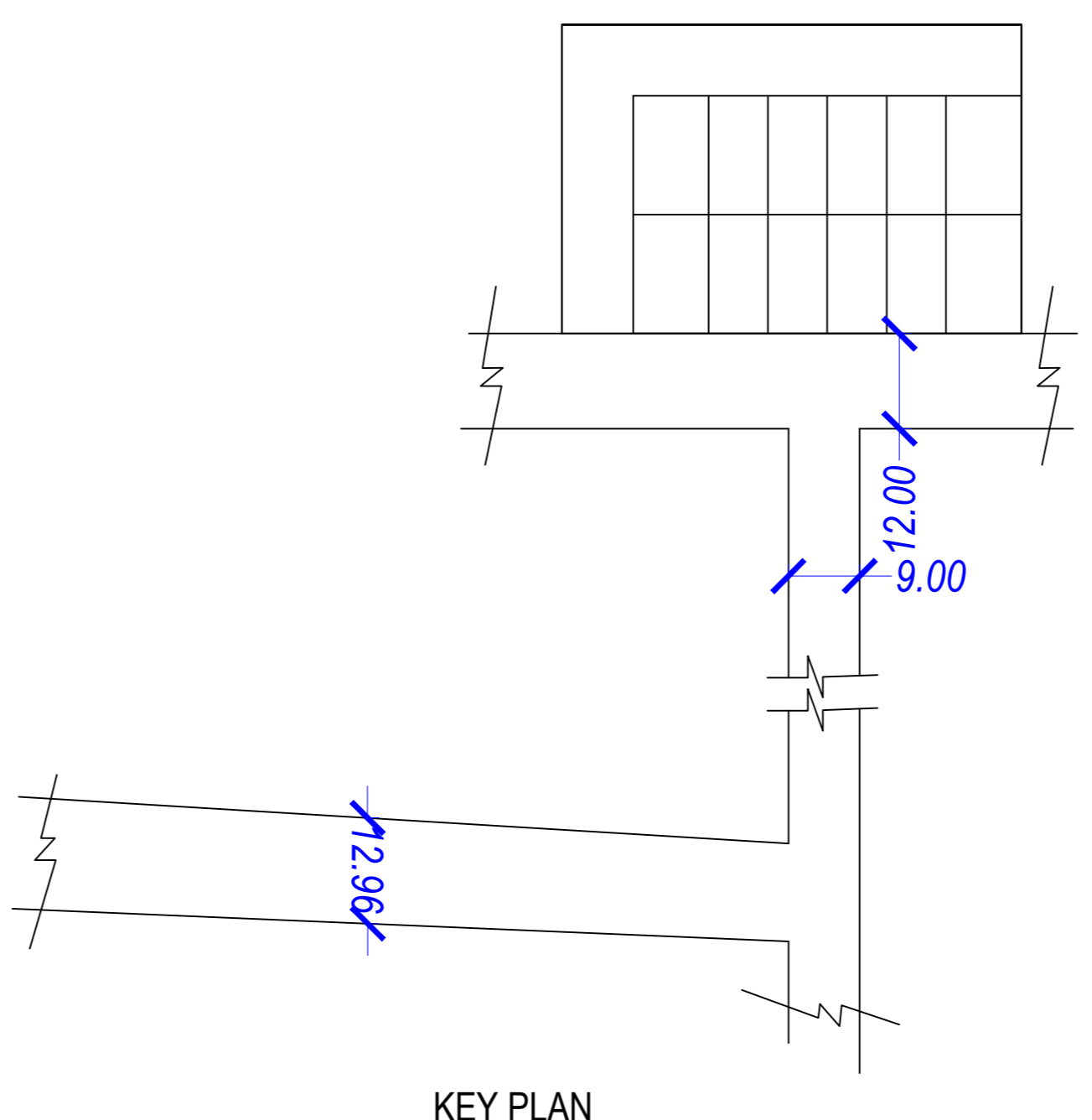

KEY PLAN

Note: - 1) This drawing is prepared as per the current prevailing Building Bye Laws.
 2) If Map sanctioned is used for purpose anything other than stated in application will lead to rejection of Map.

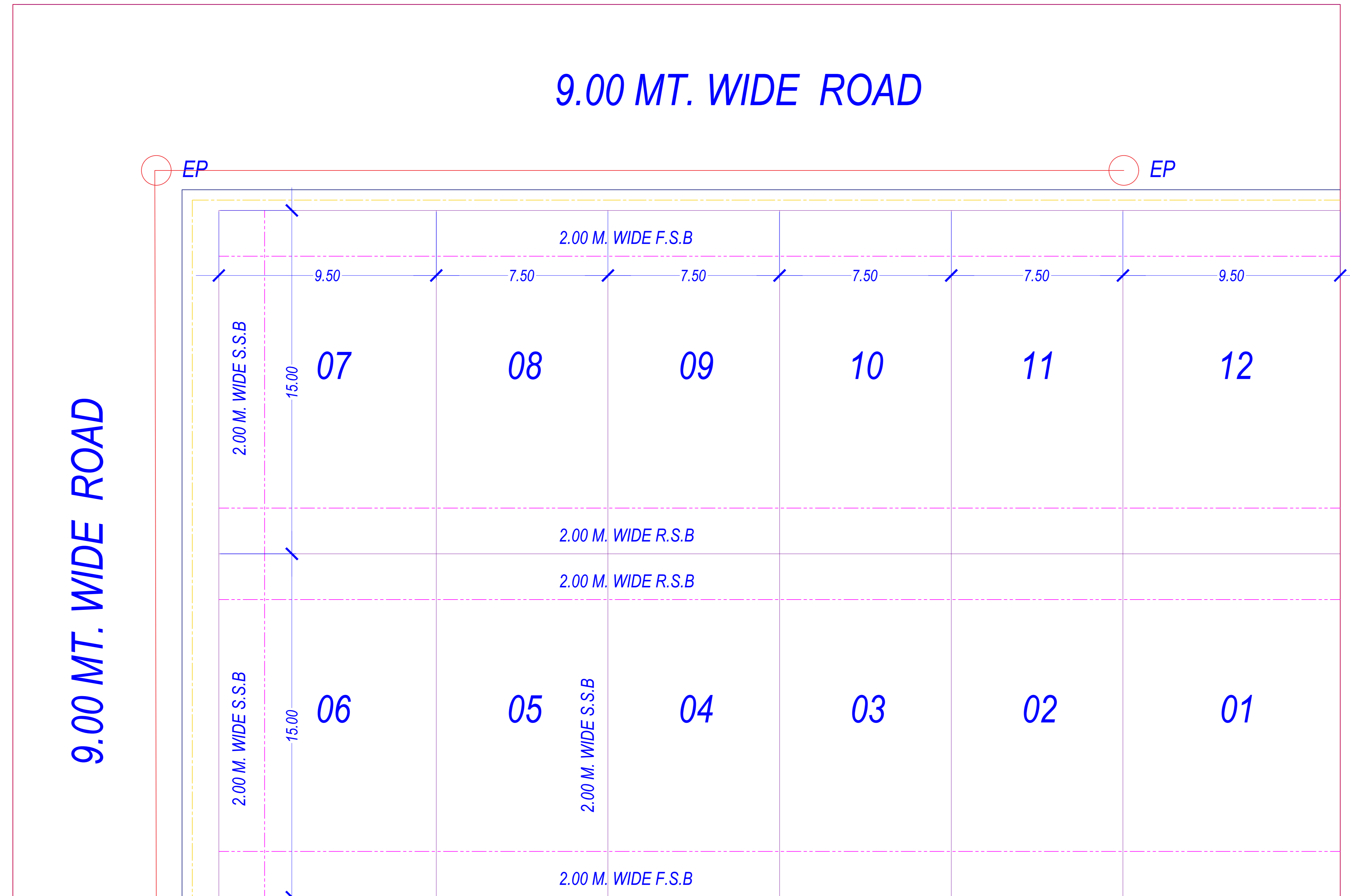

Project Title : PROPOSED LAYOUT PLAN FOR "SHIV VARDAN REAL ESTATE " ON ARAZI NO. - 896 ,MOUJA- PALI PAHARI,JHANSI.
 OWNERS: M/S SHIV VARDAN REAL ESTATE PARTNER-SHRI ARUN KUMAR PANDEY & SHRI SURESH KUMAR PREMCHANDANI

LAND AREA DETAILS :

TOTAL AREA OF LAND	2496.00 SQMT.	
BALANCE NET PLOT AREA =	2261.81 SQMT.	100%
AREA UNDER PLOTS	= 1469.85 SQMT.	64.98%
AREA UNDER ROADS	= 791.96 SQMT.	35.02%
GRAND TOTAL	= 2261.81 SQMT.	100.00%

LEGEND :-

- SCHEME BOUNDRY
- PROPOSED DRAIN
- PROPOSED TREE
- PROPOSED WATER LINE
- PROPOSED ELECTRIC POLE

12.00 MT. WIDE EXISTING ROAD

OWNER'S NAME AND SIGNATURE
 M/S SHIV VARDAN REAL ESTATE PARTNERS ARUN KUMAR PANDEY & SURESH KUMAR PREMCHANDANI,
 0015pandey@gmail.com, 9453877404

ARCHITECT'S NAME AND SIGNATURE
 SHUBHAM GUPTA
 AM175588725062019

Jhansi Development Authority

Building Plan Application Number
 JDALD/23-24/0581
 Sanctioned On
 13 Feb 2024
 Valid Till
 04 Mar 2029

Approved By
 Alok Yadav (Vice Chairman)

Examined By
 Vincet Kumar (Junior engineer)
 Jitendra Singh Sahrawar (Town Planner)
 Upma Pandey (Secretary)
 Alok Yadav (Vice Chairman)
 Upma Pandey (Secretary)

Note: - 1) This drawing is prepared as per the current prevailing Building Bye Laws.
 2) If Map sanctioned is used for purpose anything other than stated in application will lead to rejection of Map.

Total Plot Area: -	2261.81	Total FAR Area: -	0.00
Total Coverage Area: -	0.00	Total BUA Area: -	0.00