

CORNER & OTHER PLOTS AREA & SIZES

PLOT NO.	PLOT SIZE	PLOT AREA (sq.mt.)	PLOT NO.	PLOT SIZE	PLOT AREA (sq.mt.)	PLOT NO.	PLOT SIZE	PLOT AREA (sq.mt.)
A-001	15.50X7.50	116.25	B-012	16.00X9.50	152.00	C-001	17.50X9.00	157.50
A-002	15.50X7.50	116.25	B-012A	16.00X9.50	152.00	C-002	17.00X9.00	153.00
A-003	15.50X7.50	116.25	B-025	16.00X10.75	172.00	C-003	16.50X9.00	148.50
A-004	15.50X7.50	116.25	B-051	16.00X10.75	172.00	C-004	18.40X9.00	165.60
A-005	15.50X7.50	116.25	B-031	16.00X10.75	172.00	C-005	17.40X9.00	156.60
A-006	15.50X7.50	116.25	B-045	16.00X10.75	172.00	C-006	22.50X9.00	202.50
A-007	15.00X13.40	201.00	B-032	16.00X8.50	136.00	C-007	21.50X9.00	193.50
A-008	15.00X9.70	145.50	B-044	16.00X8.50	136.00	C-008	20.50X9.00	184.50
A-12A	15.00X9.70	145.50	B-057	16.00X9.50	152.00	C-009	20.00X9.00	180.00
A-014	15.00X9.70	145.50	B-069	16.00X9.50	152.00	C-010	19.00X9.00	171.00
A-019	15.00X9.70	145.50	B-064	16.00X8.75	140.00	C-011	18.00X10.50	189.00
A-020	20.10X7.50	150.75	B-069	16.00X8.75	140.00	C-021	18.00X10.50	189.00
A-021	20.10X7.50	150.75	B-083	16.00X8.75	140.00	C-037	18.00X10.50	189.00
A-022	20.10X7.50	150.75	B-088	16.00X8.75	140.00	C-038	18.00X10.50	189.00
A-023	20.10X7.50	150.75	B-099	16.00X8.75	140.00	C-034	18.00X10.50	189.00
A-024	20.10X7.50	150.75	B-094	16.00X8.75	140.00	TOTAL PLOTS = 15 NOS.		
A-025	20.10X7.50	150.75	B-115	16.00X8.75	140.00	PLOT NO.	PLOT SIZE	PLOT AREA (sq.mt.)
A-026	20.10X7.50	150.75	B-120	16.00X8.75	140.00	D-001	20.00X12.50	250.00
A-027	20.10X7.50	150.75	B-082	16.00X8.50	136.00	D-010	20.00X12.50	250.00
A-028	20.10X7.50	150.75	B-070	16.00X8.50	136.00	D-011	20.00X12.50	250.00
A-029	20.10X7.50	150.75	B-136	16.00X8.50	136.00	D-020	20.00X12.50	250.00
A-030	20.10X9.20	184.92	B-145	16.00X8.50	136.00	TOTAL PLOTS = 04 NOS.		
A-031	7.80X14.70	114.66	B-140	16.00X8.70	139.20			
A-032	7.50X14.80	111.00	B-141	16.00X11.90	190.40			
A-033	7.50X14.90	111.75	B-095	16.00X10.00	160.00			
A-035	7.50X15.10	113.25	B-104	16.00X10.00	160.00			
A-036	7.50X15.20	114.00	B-105	16.00X10.00	160.00			
A-037	7.50X15.30	114.75	B-114	16.00X10.00	160.00			
A-038	7.50X15.40	115.50	B-125	16.00X9.50	152.00			
A-039	7.50X15.50	116.25	B-126	16.00X9.50	152.00			
A-040	12.10X15.00	181.50	B-155	16.00X9.50	152.00			
A-041	15.00X9.50	142.50	B-156	16.00X9.50	152.00			
A-056	15.00X9.50	142.50	TOTAL PLOTS = 32 NOS.					
A-057	15.00X9.50	142.50						
A-072	15.00X9.50	142.50						
A-081	15.00X9.00	135.00						
A-082	15.00X9.00	135.00						
A-093	15.00X9.00	135.00						
A-094	15.00X9.00	135.00						
A-105	15.00X9.00	135.00						
A-106	15.00X9.00	135.00						
TOTAL PLOTS = 41 NOS.								

SETBACK DETAILS

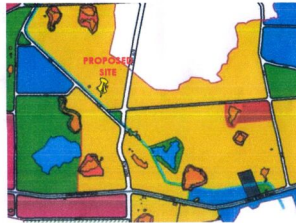
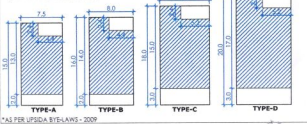

SITE LOCATION IN LIDA MASTER PLAN



LOCATION PLAN

GREEN AREA DETAIL:

S.NO.	DESCRIPTION	AREA(SQ.MT.)
1.	GREEN-01	462.90 sq.mt.
2.	GREEN-02	322.80 sq.mt.
3.	GREEN-03	360.00 sq.mt.
4.	GREEN-04	952.00 sq.mt.
5.	GREEN-05	608.30 sq.mt.
6.	GREEN-06	2520.00 sq.mt.
7.	GREEN-07	1186.00 sq.mt.
8.	GREEN-08	672.00 sq.mt.
9.	GREEN-09	468.00 sq.mt.
10.	GREEN-10	432.20 sq.mt.
11.	GREEN-11	752.00 sq.mt.
12.	GREEN-12	294.40 sq.mt.
13.	GREEN-13	770.70 sq.mt.
14.	GREEN-14	962.50 sq.mt.
15.	GREEN-15	424.50 sq.mt.
16.	GREEN-16	1321.80 sq.mt.
17.	GREEN-17	788.30 sq.mt.
18.	GREEN-18	966.80 sq.mt.
19.	GREEN-19	937.70 sq.mt.
TOTAL GREEN AREA		16172.60 sq.mt.

NOTE: PLANTATION & GREEN COVER

- Park area = 15172.60 sq.mt.
- Green area shall be provided as well maintained park. Total no. of 123 trees/plants @ 125 trees per ha., shall be part of this residential colony planted along roads & inside parks.
- 18/12.9 mt. wide road shall be lined with eucalyptus trees @ 7.5mt.C/C.
- A Separate Landscape plan is attached showing plantation layout with the categories of trees.
- Refer landscape layout for trees/plants location.

ROAD AREA DETAIL:

S.NO.	DESCRIPTION	LENGTH (MT.)	WIDTH (MT.)	AREA (SQ.MT.)
1.	18.0 MT. ROAD			
R1		68.07	18.0	1225.26
TOTAL				1225.26
2.	12.0 MT. ROAD			
R2		243.96	12.0	2926.32
R19		212.73	12.0	2552.76
R27		224.78	12.0	2697.36
TOTAL				8176.30
3.	9.0 MT. ROAD			
R3		198.64	9.0	1787.80
R4		235.00	9.0	2115.00
R5		105.00	9.0	945.00
R6		105.00	9.0	945.00
R8		105.00	9.0	945.00
R9		105.00	9.0	945.00
R10		61.50	9.0	553.50
R11		61.50	9.0	553.50
R12		61.50	9.0	553.50
R13		61.50	9.0	553.50
R14		49.50	9.0	445.50
R16		49.50	9.0	445.50
R17		45.78	9.0	412.10
R20		162.40	9.0	1461.50
R22		153.77	9.0	1383.93
R25		124.03	9.0	1116.30
R28		80.28	9.0	722.50
R29		49.25	9.0	443.30
R30		68.47	9.0	586.30
TOTAL				17593.40
4.	7.5 MT. ROAD			
R11		50.00	7.5	375.00
R15		82.00	7.5	615.00
R18		55.40	7.5	415.50
R21		81.22	7.5	609.20
R22		61.67	7.5	462.50
R24		71.00	7.5	532.50
R31		49.41	7.5	370.50
TOTAL				3380.30
5.	5.0 MT. PATHWAY			
R26		38.00	5.0	190.00
R32		18.44	5.0	92.20
TOTAL				282.20
TOTAL AREA OF ROAD				30572.90



LAND DETAIL OF VILLAGE - MAKHDOOMPUR KAITHI PARGANA BIJNAOR, LUCKNOW

S.NO.	COMPANY NAME	KHASRA NO.	AREA(HECT.)
1.	KRISHNA BIZ SOLUTIONS PRIVATE LIMITED	607KH	0.078
2.	TANKISH INFRA TECH PVT. LTD.	590	2.629
3.	TANKISH INFRA TECH PVT. LTD.	581	0.915
4.	TANKISH INFRA TECH PVT. LTD.	587	0.115
5.	TANKISH INFRA TECH PVT. LTD.	588	0.11
6.	SUSHMA REAL ESTATE TRADERS INDIA PVT. LTD.	598	3.308
7.	SUSHMA REAL ESTATE TRADERS INDIA PVT. LTD.	595	0.095
8.	SUSHMA REAL ESTATE TRADERS INDIA PVT. LTD.	596	0.805
9.	TIARA HOLDING PVT. LTD.	607Ka	2.312
10.	TANYA MODERATORS PVT. LTD.	593	0.025
11.	TANYA MODERATORS PVT. LTD.	594	0.164
TOTAL LAND AREA(AS PER RECORD)			10.356 Hect. or 25.57932 Acres

DENSITY CALCULATION

PLOTTED DEVELOPMENT					
PLOT TYPE	PLOT SIZE/ TYPE	NOS.	TOTAL NOS.	PERSONS/PLOT	PERSONS
TYPE A	7.50X15.00	73	114	10 NOS.	1140
CORNER & OTHERS PLOTS	TYPE A	41			
TYPE B	8.00X16.00	128	160	10 NOS.	1600
CORNER & OTHERS PLOTS	TYPE B	32			
TYPE C	9.00X18.00	39	54	10 NOS.	540
CORNER & OTHERS PLOTS	TYPE C	15			
TYPE D	10.00X20.00	16	20	10 NOS.	200
CORNER & OTHERS PLOTS	TYPE D	04			
TOTAL		348	348		3480

ACHIEVED POPULATION = 3480 PERSONS
PROVISION FOR E.W.S. & L.I.G.
 35 UNITS OF E.W.S. & 35 UNITS OF L.I.G. HAVE BEEN PROVIDED AGAINST 348 NOS. RESIDENTIAL PLOTS.

AREA STATEMENT (AS PER SITE)

S.NO.	DESCRIPTION	AREA(sq.mt.)	AREA(hect.)
1.	TOTAL LAND AREA(AS PER SITE)	10104.40	10.01044
2.	AREA UNDER ROAD WIDENING	1024.00	0.10240
3.	NET LAND AREA	9980.40	9.98084

LAND USE DISTRIBUTION AS PER LAYOUT PLAN

S.NO.	DESCRIPTION	PLOTTED E.W.S. & L.I.G.	AREA		
			in sq.mt.	in hect.	% achieved
1.	RESIDENTIAL AREA		48246.00		
			1921.30		
			50167.30	5.0167	50.63%
2.	COMMERCIAL	SHOPPING	688.40		
		SUB TOTAL	688.40	0.0688	0.70%
3.	CLUB	CLUB BUILDING	911.70		
		SUB TOTAL	911.70	0.0912	0.92%
4.	SCHOOL	SCHOOL	1018.60		
		SUB TOTAL	1018.60	0.1019	1.03%
5.	GREEN COVER	GREEN/GREEN BELT	15172.60		
		SUB TOTAL	15172.60	1.5173	15.31%
6.	SERVICES	E.S.S.	187.90		
		S.T.P.	361.30		
		SUB TOTAL	549.20	0.0549	0.55%
7.	ROAD AREA	ROAD AREA	30572.60		
		SUB TOTAL	30572.60	3.0573	30.86%

NOTE:
 Refer MEP drawing for details of R.W.H., Septic Tank, Recharge Pit etc.
 Total Required Electrical load = 1545.19 KW.

PROJECT:
PROPOSED MINI TOWNSHIP FOR LJK CONSTRUCTION INDIA PVT. LTD. AT MAKHDOOMPUR KAITHI, LUCKNOW

NOTES:
 PROFILE AND LAND OWNERSHIP DETAILS PROVIDED & VERIFIED BY THE DEVELOPER.
 THIS DRAWING IS VALID ONLY IF SIGNED BY THE DEVELOPER.
 SIZR PLAN DETAILS IS BEING VERIFIED BY THE DEVELOPER FOR ITS ACCURACY. ARCHITECT IS NOT RESPONSIBLE FOR THE SAME.

TITLE:
SUBMISSION DRAWING

SCALE: 1:1000
DATE: 16.12.2022

DEVELOPER/PROMOTER:
 For LJK CONSTRUCTION INDIA PVT. LTD.
 LJK CONSTRUCTION INDIA PVT. LTD.

ARCHITECT:
 AR. SANJAY KR. GUPTA
 espaces

जोड़ित ब्रह्म एम्-टी. के प्लॉट में बंधक है। इनका सिद्ध एम्-टी. डबल अनुमति किसे जोन के उपर ही किया जाएगा।

स्वीकृत
 20/11/2023
 अधिकारी का नाम: 05 ब्रह्म
 जमीन का नाम: जयसिंहपुर

राजेश कुमार
 परियोजना अधिकारी
 जमीनी लखनऊ (एम्-टी.डी.) लखनऊ

CORNER & OTHER PLOTS AREA & SIZES

PLOT NO.	PLOT SIZE	PLOT AREA (sq.mt.)	PLOT NO.	PLOT SIZE	PLOT AREA (sq.mt.)	PLOT NO.	PLOT SIZE	PLOT AREA (sq.mt.)
A-001	15.50X7.50	116.25	B-012	16.00X9.50	152.00	C-001	17.50X9.00	157.50
A-002	15.50X7.50	116.25	B-012A	16.00X9.50	152.00	C-002	17.00X9.00	153.00
A-003	15.50X7.50	116.25	B-025	16.00X10.75	172.00	C-003	16.50X9.00	148.50
A-004	15.50X7.50	116.25	B-051	16.00X10.75	172.00	C-004	18.60X9.00	167.40
A-005	15.50X7.50	116.25	B-031	16.00X10.75	172.00	C-005	17.60X9.00	158.40
A-006	15.50X7.50	116.25	B-045	16.00X10.75	172.00	C-006	22.50X9.00	202.50
A-007	15.00X13.40	201.00	B-032	16.00X8.50	136.00	C-007	21.50X9.00	193.50
A-008	15.00X9.70	145.50	B-044	16.00X8.50	136.00	C-008	20.50X9.00	184.50
A-009	15.00X9.70	145.50	B-057	16.00X9.50	152.00	C-009	20.00X9.00	180.00
A-010	15.00X9.70	145.50	B-058	16.00X9.50	152.00	C-010	19.00X9.00	171.00
A-011	15.00X9.70	145.50	B-064	16.00X8.75	140.00	C-011	18.00X10.50	189.00
A-020	20.10X7.50	150.75	B-069	16.00X8.75	140.00	C-021	18.00X10.50	189.00
A-021	20.10X7.50	150.75	B-083	16.00X8.75	140.00	C-037	18.00X10.50	189.00
A-022	20.10X7.50	150.75	B-088	16.00X8.75	140.00	C-038	18.00X10.50	189.00
A-023	20.10X7.50	150.75	B-089	16.00X8.75	140.00	C-054	18.00X10.50	189.00
A-024	20.10X7.50	150.75	B-094	16.00X8.75	140.00			
A-025	20.10X7.50	150.75	B-115	16.00X8.75	140.00			
A-026	20.10X7.50	150.75	B-120	16.00X8.75	140.00			
A-027	20.10X7.50	150.75	B-082	16.00X8.50	136.00			
A-028	20.10X7.50	150.75	B-070	16.00X8.50	136.00			
A-029	20.10X7.50	150.75	B-136	16.00X8.50	136.00			
A-030	20.10X9.20	184.92	B-145	16.00X8.50	136.00			
A-031	7.80X14.70	114.66	B-140	16.00X8.70	139.20			
A-032	7.50X14.80	111.00	B-141	16.00X11.90	190.40			
A-033	7.50X14.90	111.75	B-095	16.00X10.00	160.00			
A-035	7.50X15.10	113.25	B-104	16.00X10.00	160.00			
A-036	7.50X15.20	114.00	B-105	16.00X10.00	160.00			
A-037	7.50X15.30	114.75	B-114	16.00X10.00	160.00			
A-038	7.50X15.40	115.50	B-125	16.00X9.50	152.00			
A-039	7.50X15.00	112.50	B-126	16.00X9.50	152.00			
A-040	12.10X15.00	181.50	B-155	16.00X9.50	152.00			
A-041	15.00X9.50	142.50	B-156	16.00X9.50	152.00			
A-056	15.00X9.50	142.50						
A-057	15.00X9.50	142.50						
A-072	15.00X9.50	142.50						
A-081	15.00X9.00	135.00						
A-082	15.00X9.00	135.00						
A-093	15.00X9.00	135.00						
A-094	15.00X9.00	135.00						
A-105	15.00X9.00	135.00						
A-106	15.00X9.00	135.00						
TOTAL PLOTS = 41 NOS.								

ROAD AREA DETAIL:

S.NO.	DESCRIPTION	LENGTH (MT.)	WIDTH (MT.)	AREA (SQ.MT.)
1.	18.0 MT. ROAD			
	R1	68.07	18.0	1225.20
	TOTAL			1225.20
2.	12.0 MT. ROAD			
	R2	243.86	12.0	2926.30
	R19	212.73	12.0	2552.70
	R27	224.78	12.0	2697.30
	TOTAL			8176.30
3.	9.0 MT. ROAD			
	R3	198.64	9.0	1787.80
	R4	235.00	9.0	2115.00
	R5	105.00	9.0	945.00
	R6	105.00	9.0	945.00
	R7	105.00	9.0	945.00
	R8	105.00	9.0	945.00
	R9	105.00	9.0	945.00
	R10	61.50	9.0	553.50
	R12	61.50	9.0	553.50
	R13	67.88	9.0	610.90
	R14	49.50	9.0	445.50
	R16	49.50	9.0	445.50
	R17	45.78	9.0	412.10
	R20	182.40	9.0	1641.50
	R23	150.37	9.0	1341.70
	R25	124.03	9.0	1116.30
	R28	80.28	9.0	722.50
	R29	49.25	9.0	443.30
	R30	68.47	9.0	589.30
	TOTAL			17503.40
4.	7.5 MT. ROAD			
	R11	50.00	7.5	375.00
	R15	82.00	7.5	615.00
	R18	55.40	7.5	415.50
	R21	81.22	7.5	609.20
	R22	61.67	7.5	462.50
	R24	71.00	7.5	532.50
	R31	49.41	7.5	370.60
	TOTAL			3380.30
5.	5.0 MT. PATHWAY			
	R26	39.00	5.0	195.00
	R32	18.44	5.0	92.20
	TOTAL			287.40
	TOTAL AREA OF ROAD			30572.60

Rain Water Harvesting with Recharge Pit(09 Nos.)

NOTE:
 · Refer MEP drawing for details of R.W.H., Septic Tank, Recharge Pit etc.
 · Total Required Electrical load = 1545.19 KW.

PROJECT:
PROPOSED MINI TOWNSHIP FOR LJK CONSTRUCTION INDIA PVT. LTD. AT MAKHDOOMPUR KAITHI, LUCKNOW

NOTES:
 · PROFILE AND LAND OWNERSHIP DETAILS PROVIDED & VERIFIED BY THE DEVELOPER.
 · THIS DRAWING IS VALID ONLY IF SIGNED BY THE DEVELOPER.
 · SIZR PLAN DETAILS IS BEING VERIFIED BY THE DEVELOPER FOR ITS ACCURACY. ARCHITECT IS NOT RESPONSIBLE FOR THE SAME.

SETBACK DETAILS

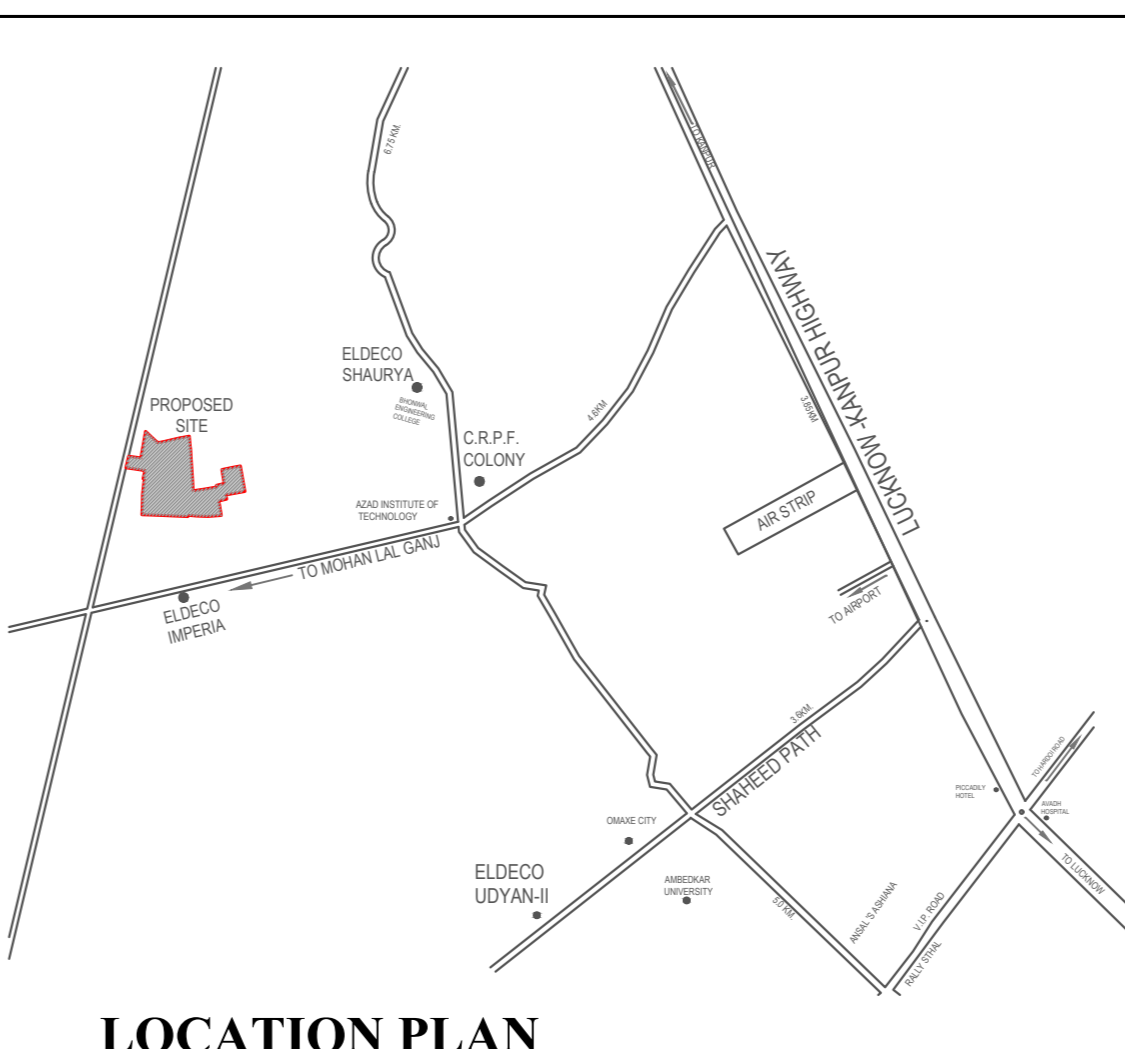
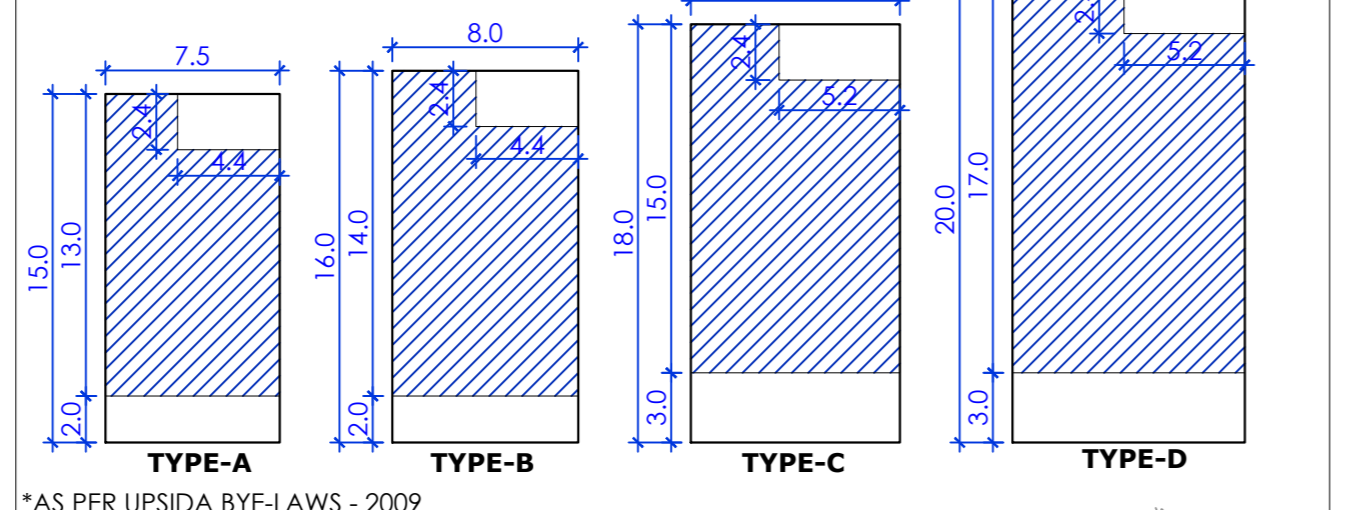

GREEN AREA DETAIL:

S.NO.	DESCRIPTION	AREA(SQ.MT.)
1.	GREEN-01	462.90 sq.mt.
2.	GREEN-02	322.50 sq.mt.
3.	GREEN-03	360.00 sq.mt.
4.	GREEN-04	952.00 sq.mt.
5.	GREEN-05	608.30 sq.mt.
6.	GREEN-06	2520.00 sq.mt.
7.	GREEN-07	1166.00 sq.mt.
8.	GREEN-08	672.00 sq.mt.
9.	GREEN-09	468.00 sq.mt.
10.	GREEN-10	432.20 sq.mt.
11.	GREEN-11	752.00 sq.mt.
12.	GREEN-12	294.40 sq.mt.
13.	GREEN-13	770.70 sq.mt.
14.	GREEN-14	952.50 sq.mt.
15.	GREEN-15	424.50 sq.mt.
16.	GREEN-16	1321.80 sq.mt.
17.	GREEN-17	788.30 sq.mt.
18.	GREEN-18	966.80 sq.mt.
19.	GREEN-19	937.70 sq.mt.
	TOTAL GREEN AREA	15172.60 sq.mt.

NOTE: PLANTATION & GREEN COVER
 · Park area = 15172.60 sq.mt.
 · Green area shall be provided as well maintained park. Total no. of 1239 trees/plants @ 125 trees per hac., shall be part of this residential colony planted along roads & inside parks.
 · 18/12/9 mt. wide road shall be lined with evergreen trees @ 7.5mt.C/C.
 · A Separate Landscape plan is attached showing plantation layout with the categories of trees.
 · Refer landscape layout for trees/plants location.

LAND DETAIL OF VILLAGE - MAKHDOOMPUR KAITHI PARGANA BIJNAOR, LUCKNOW

S.NO.	COMPANY NAME	KHASRA NO.	AREA(HECT.)
1.	KRISHNA BIZ SOLUTIONS PRIVATE LIMITED	607KH	0.078
2.	TANKISH INFRA TECH PVT. LTD.	590	2.629
3.	TANKISH INFRA TECH PVT. LTD.	581	0.915
4.	TANKISH INFRA TECH PVT. LTD.	587	0.115
5.	TANKISH INFRA TECH PVT. LTD.	588	0.11
6.	SUSHMA REAL ESTATE TRADERS INDIA PVT. LTD.	598	3.308
7.	SUSHMA REAL ESTATE TRADERS INDIA PVT. LTD.	595	0.605
8.	SUSHMA REAL ESTATE TRADERS INDIA PVT. LTD.	596	0.095
9.	TIARA HOLDING PVT. LTD.	607Ka	2.312
10.	TANYA MODERATORS PVT. LTD.	593	0.025
11.	TANYA MODERATORS PVT. LTD.	594	0.164
TOTAL LAND AREA(AS PER RECORD)			10.356 Hect. or 25.57932 Acres

DENSITY CALCULATION

PLOT TYPE	PLOT SIZE/ TYPE	NOS.	TOTAL NOS.		PERSONS		SETBACKS		
			PERSONS/PLOT	PERSONS	FRONT	REAR	SIDE		
CORNER & OTHERS PLOTS	TYPE A	41	114	10 NOS.	1140				
CORNER & OTHERS PLOTS	TYPE B	32	160	10 NOS.	1600				
CORNER & OTHERS PLOTS	TYPE C	39	54	10 NOS.	540				
CORNER & OTHERS PLOTS	TYPE D	16	20	10 NOS.	200				
	TOTAL	348	348		3480				

SET BACKS WILL BE AS PER TABLE NO.1 ON PAGE 33 OF LUCKNOW INDUSTRIAL DEVELOPMENT AUTHORITY BYE LAWS-2009.

ACHIEVED POPULATION = 3480 PERSONS
PROVISION FOR E.W.S. & L.I.G.
 35 UNITS OF E.W.S. & 35 UNITS OF L.I.G. HAVE BEEN PROVIDED AGAINST 348 NOS. RESIDENTIAL PLOTS.

AREA STATEMENT(AS PER SITE)

S.NO.	DESCRIPTION	AREA(sq.mt.)	AREA(hect.)
1.	TOTAL LAND AREA(AS PER SITE)	100104.40	10.01044
2.	AREA UNDER ROAD WIDENING	1024.00	0.10240
3.	NET LAND AREA	99080.40	9.90804

LAND USE DISTRIBUTION AS PER LAYOUT PLAN

S.NO.	DESCRIPTION	PLOTTED	AREA		
			in sq.mt.	in hect.	% achieved
1	RESIDENTIAL AREA	PLOTTED	48246.00		
		E.W.S. & L.I.G.	1921.30		
		SUB TOTAL	50167.30	5.0167	50.63%
2	COMMERCIAL	SHOPPING	688.40		
		SUB TOTAL	688.40	0.0688	0.70%
3	CLUB	CLUB BUILDING	911.70		
		SUB TOTAL	911.70	0.0912	0.92%
4	SCHOOL	SCHOOL	1018.60		
		SUB TOTAL	1018.60	0.1019	1.03%
5	GREEN COVER	GREEN/GREEN BELT	15172.60		
		SUB TOTAL	15172.60	1.5173	15.31%
6	SERVICES	E.S.S.	187.90		
		S.T.P.	361.30		
		SUB TOTAL	549.20	0.0549	0.55%
7	ROAD AREA	ROAD AREA	30572.60		
		SUB TOTAL	30572.60	3.0573	30.86%

TITLE: SUBMISSION DRAWING
SCALE: 1:1000
DATE: 16.12.2022
NORTH: [North Arrow]
DEVELOPER/PROMOTER: LJK CONSTRUCTION INDIA PVT. LTD.
ARCHITECT: AR. SANJAY KR. GUPTA
espaces