

KEY PLAN (N.T.S.)

Plot No.	Front	Side	Depth	Area	Coverage
738	1.50	-	-	1.50	0.00
739	1.50	-	-	1.50	0.00
740	1.50	-	-	1.50	0.00
741	1.50	-	-	1.50	0.00
742	1.50	-	-	1.50	0.00
743	1.50	-	-	1.50	0.00
744	1.50	-	-	1.50	0.00
745	1.50	-	-	1.50	0.00
746	1.50	-	-	1.50	0.00
747	1.50	-	-	1.50	0.00
748	1.50	-	-	1.50	0.00
749	1.50	-	-	1.50	0.00
750	1.50	-	-	1.50	0.00
751	1.50	-	-	1.50	0.00
752	1.50	-	-	1.50	0.00
753	1.50	-	-	1.50	0.00
754	1.50	-	-	1.50	0.00
755	1.50	-	-	1.50	0.00
756	1.50	-	-	1.50	0.00
757	1.50	-	-	1.50	0.00
758	1.50	-	-	1.50	0.00
759	1.50	-	-	1.50	0.00
760	1.50	-	-	1.50	0.00
761	1.50	-	-	1.50	0.00
762	1.50	-	-	1.50	0.00
763	1.50	-	-	1.50	0.00
764	1.50	-	-	1.50	0.00
765	1.50	-	-	1.50	0.00
766	1.50	-	-	1.50	0.00
767	1.50	-	-	1.50	0.00
768	1.50	-	-	1.50	0.00
769	1.50	-	-	1.50	0.00
770	1.50	-	-	1.50	0.00
771	1.50	-	-	1.50	0.00
772	1.50	-	-	1.50	0.00
773	1.50	-	-	1.50	0.00
774	1.50	-	-	1.50	0.00
775	1.50	-	-	1.50	0.00
776	1.50	-	-	1.50	0.00
777	1.50	-	-	1.50	0.00
778	1.50	-	-	1.50	0.00
779	1.50	-	-	1.50	0.00
780	1.50	-	-	1.50	0.00
781	1.50	-	-	1.50	0.00
782	1.50	-	-	1.50	0.00
783	1.50	-	-	1.50	0.00
784	1.50	-	-	1.50	0.00
785	1.50	-	-	1.50	0.00
786	1.50	-	-	1.50	0.00
787	1.50	-	-	1.50	0.00
788	1.50	-	-	1.50	0.00
789	1.50	-	-	1.50	0.00
790	1.50	-	-	1.50	0.00
791	1.50	-	-	1.50	0.00
792	1.50	-	-	1.50	0.00
793	1.50	-	-	1.50	0.00
794	1.50	-	-	1.50	0.00
795	1.50	-	-	1.50	0.00
796	1.50	-	-	1.50	0.00
797	1.50	-	-	1.50	0.00
798	1.50	-	-	1.50	0.00
799	1.50	-	-	1.50	0.00
800	1.50	-	-	1.50	0.00

OWNER'S NAME AND SIGNATURE
 MANMOHAN SINGH
 CHHABRA, vickyhabra2009@gmail.com, 9359101677
 SATNAM KAUR, vickyhabra2009@gmail.com, 9359101677
 MANPREET KAUR, vickyhabra2009@gmail.com, 9359101677

ARCHENG'S NAME AND SIGNATURE
 SUMIT AGARWAL
 CA/1999/24025

Bareilly Development Authority

Building Plan Application Number
 BDA/LD/22-23/0147
 Sanctioned On
 23 Aug 2023
 Valid Till
 24 Aug 2028
 Approved By
 Jogindra Singh (Vice Chairman)
 Examined By
 Arvind Kumar Srivastava (Junior engineer)
 Rankumar Chaudhary (Assistant Engineer)
 Ashu Mittal (Supriendant/Executive Engineer)
 ASHU MITTAL (Chief Town Planner)
 Yogendra Kumar (Secretary)
 Jogindra Singh (Vice Chairman)

Note: - 1) This drawing is prepared as per the current prevailing Building Bye Laws.
 2) If Map sanctioned is used for purpose anything other than stated in application will lead to rejection of Map.

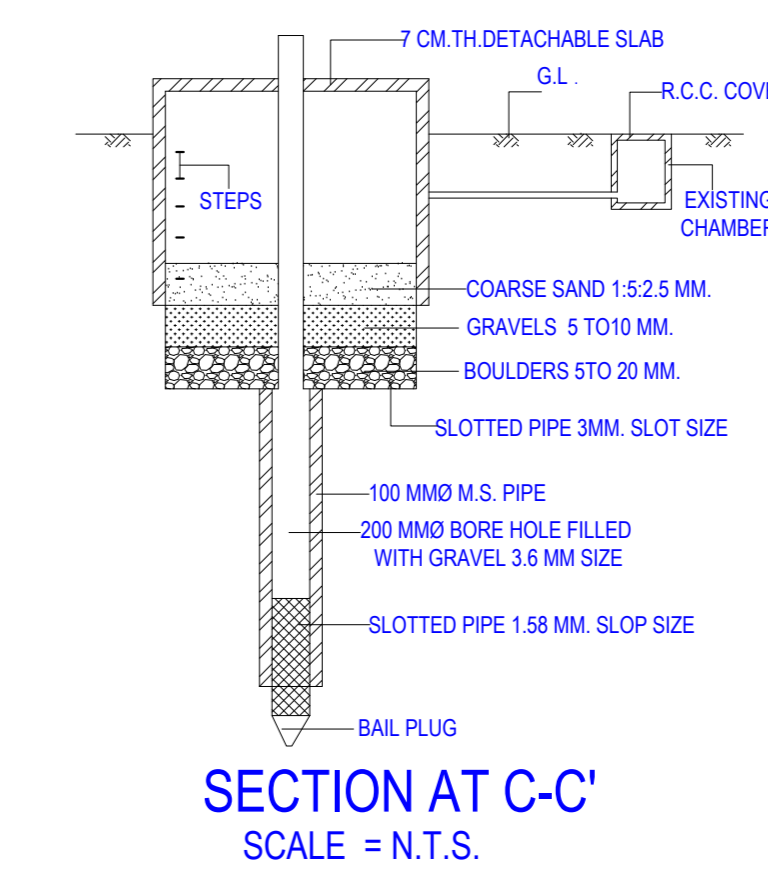
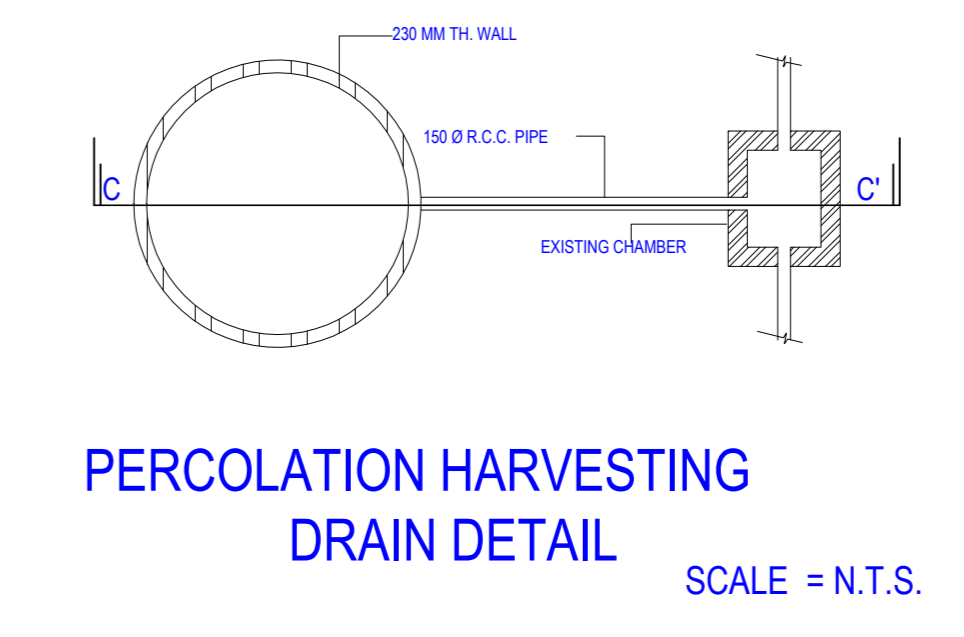
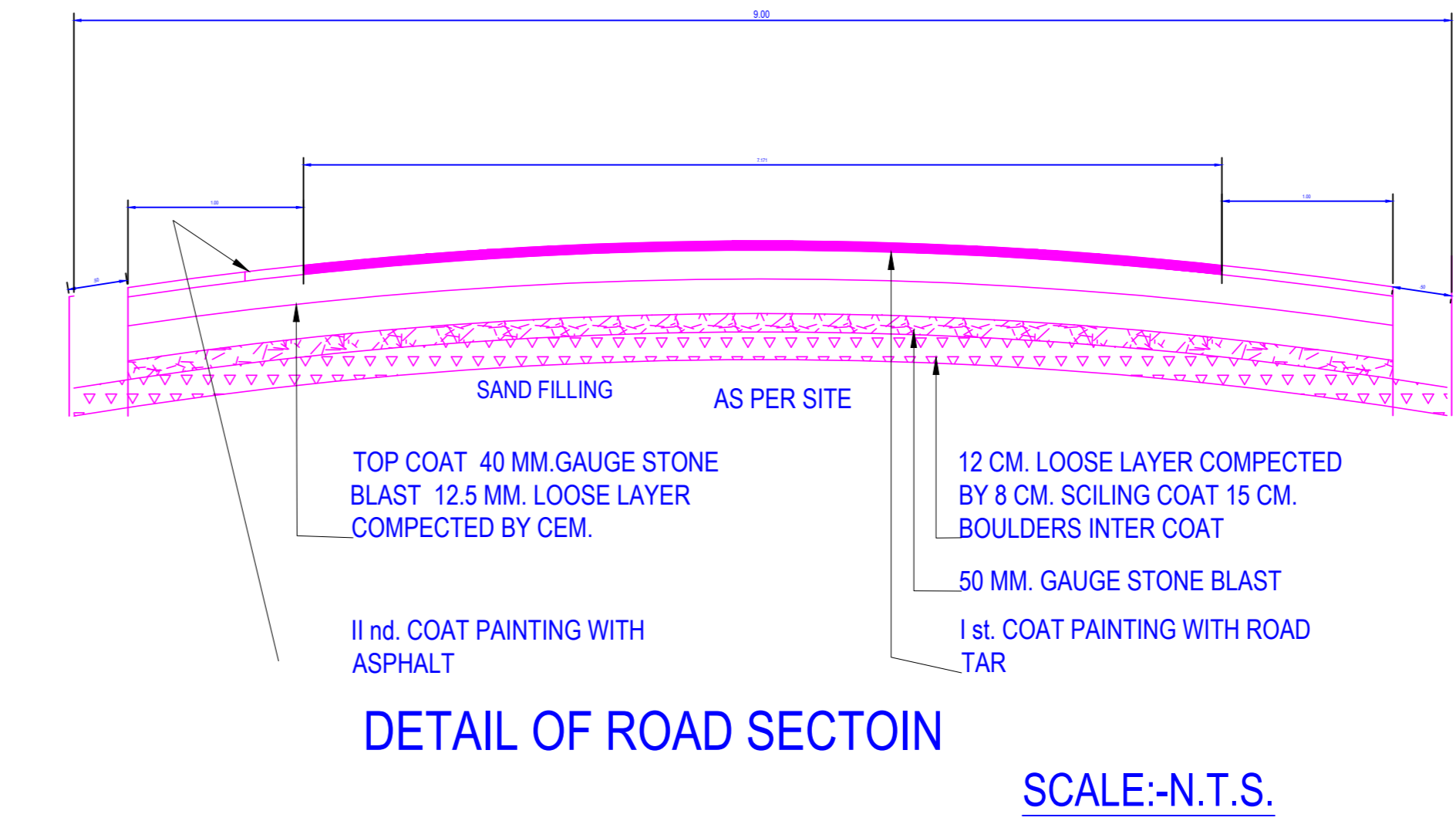
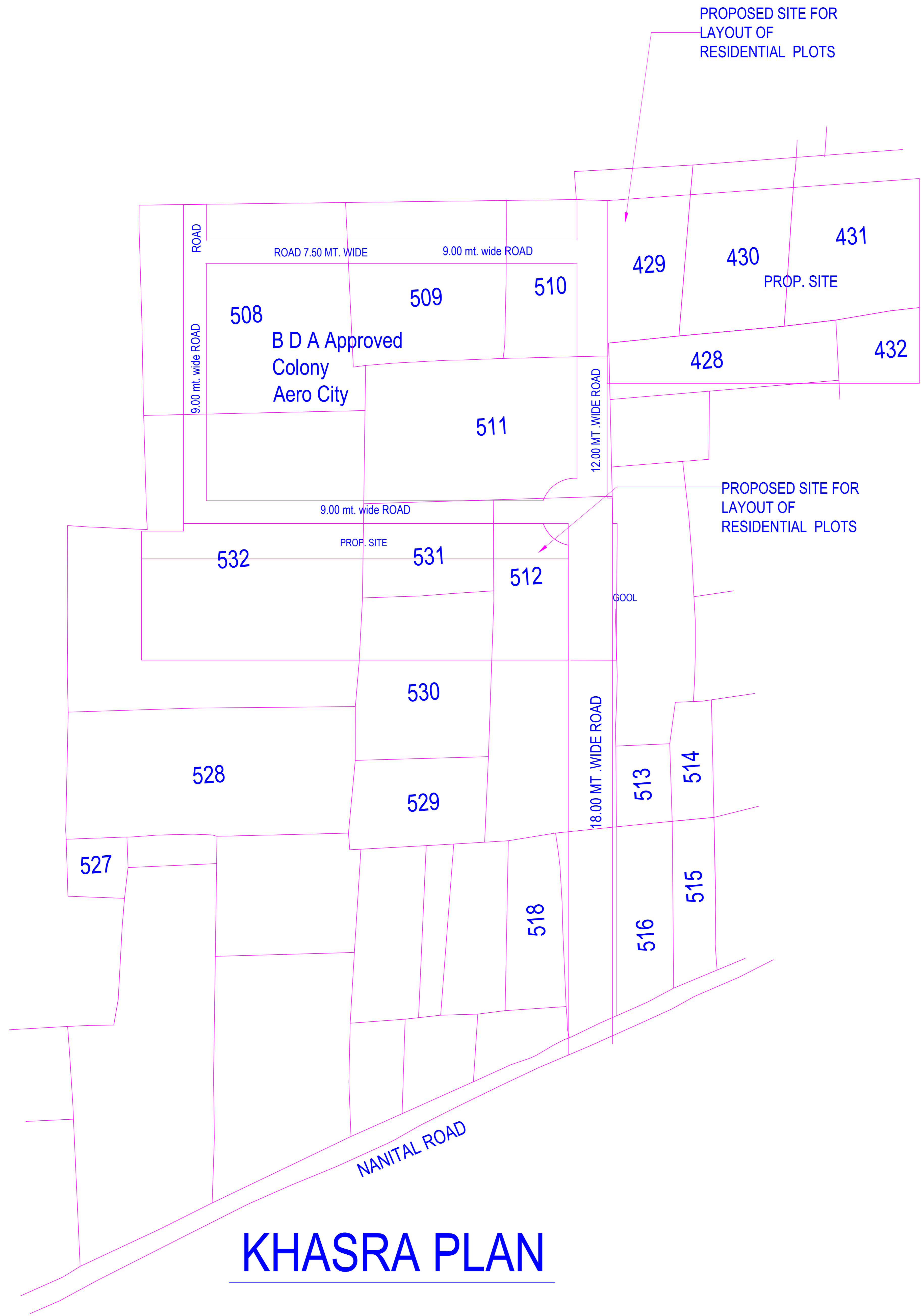

OWNER'S NAME AND SIGNATURE
MANMOHAN SINGH CHHABRA, vickychhabra2009@gmail.com, 9359101677
SATNAM KAUR, vickychhabra2009@gmail.com, 9359101677
MANPREET KAUR, vickychhabra2009@gmail.com, 9359101677

ARCHENGE'S NAME AND SIGNATURE
SUNIT AGARWAL
CA/1999/24025



Building Plan Application Number
BDA/LD/22-23/0147

Sanctioned On
23 Aug 2023

Valid Till
24 Aug 2028

Approved By
Jogindra Singh (Vice Chairman)

Examined By
Arvind Kumar Srivastava (Junior engineer)

Ramkumar Chaudhary (Assistant Engineer)

Ashu Mittal (Supriendant/Executive Engineer)

ASHU MITTAL (Chief Town Planner)

Yogendra Kumar (Secretary)

Jogindra Singh (Vice Chairman)

Note: - 1) This drawing is prepared as per the current prevailing Building Bye Laws.
2) If Map sanctioned is used for purpose anything other than stated in application will lead to rejection of Map.

Total Plot Area :-	11211.55	Total FAR Area :-	0.00
Total Coverage Area :-	0.00	Total BUA Area :-	0.00