

FOR OFFICE :-

PROJECT TITLE-

**PROPOSED RESIDENTIAL
SUBMISSION DRAWING FOR THE
VILLA ON PLOT NO - 299 P1
POCKET - L TYPE- E OMAXE HI-TECH
CITY AT LUCKNOW**

AREA STATEMENT

S.NO.	PARTICULARS	SQ.MTR.
1.	PLOT AREA	162.0
2.	PERMISSIBLE GROUND FLOOR COVERAGE (65%)	105.300
3.	PROPOSED GROUND COVERAGE(64.19%)	104.00
4.	PROPOSED FIRST FLOOR AREA	97.166
5.	PROPOSED SECOND FLOOR AREA	56.865
6.	PROPOSED TERRACE FLOOR AREA	0.0
7.	PROPOSED PORCH AREA	10.08
8.	PERMISSIBLE F. A. R. (2.0)	324.00
9.	PROPOSED F. A. R. = [G.F. + F.F.+S.F](1.592)	258.031
10.	TOTAL COVERED AREA (3+4+5+6+7)	268.11

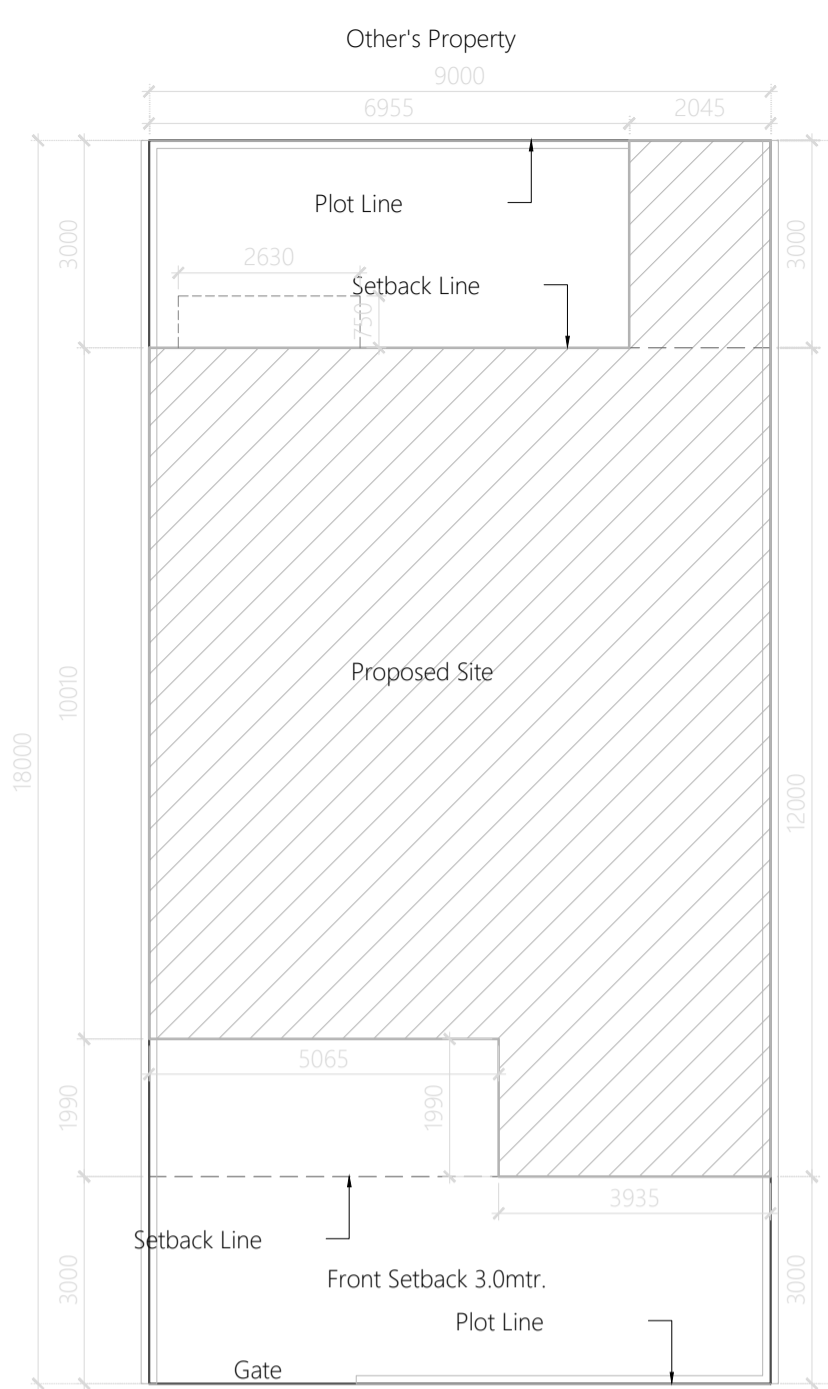

Site Plan
SCALE -1:100

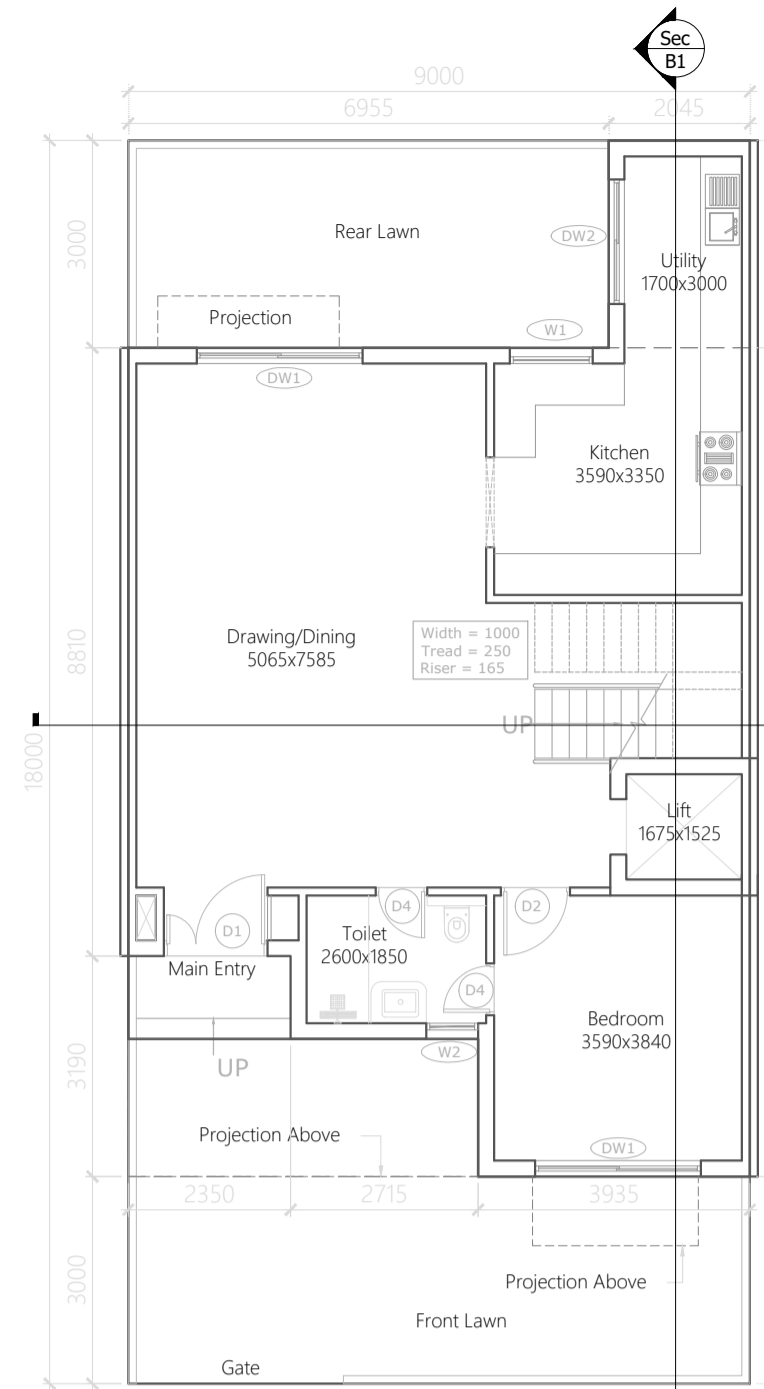

Ground Floor Plan
SCALE -1:100

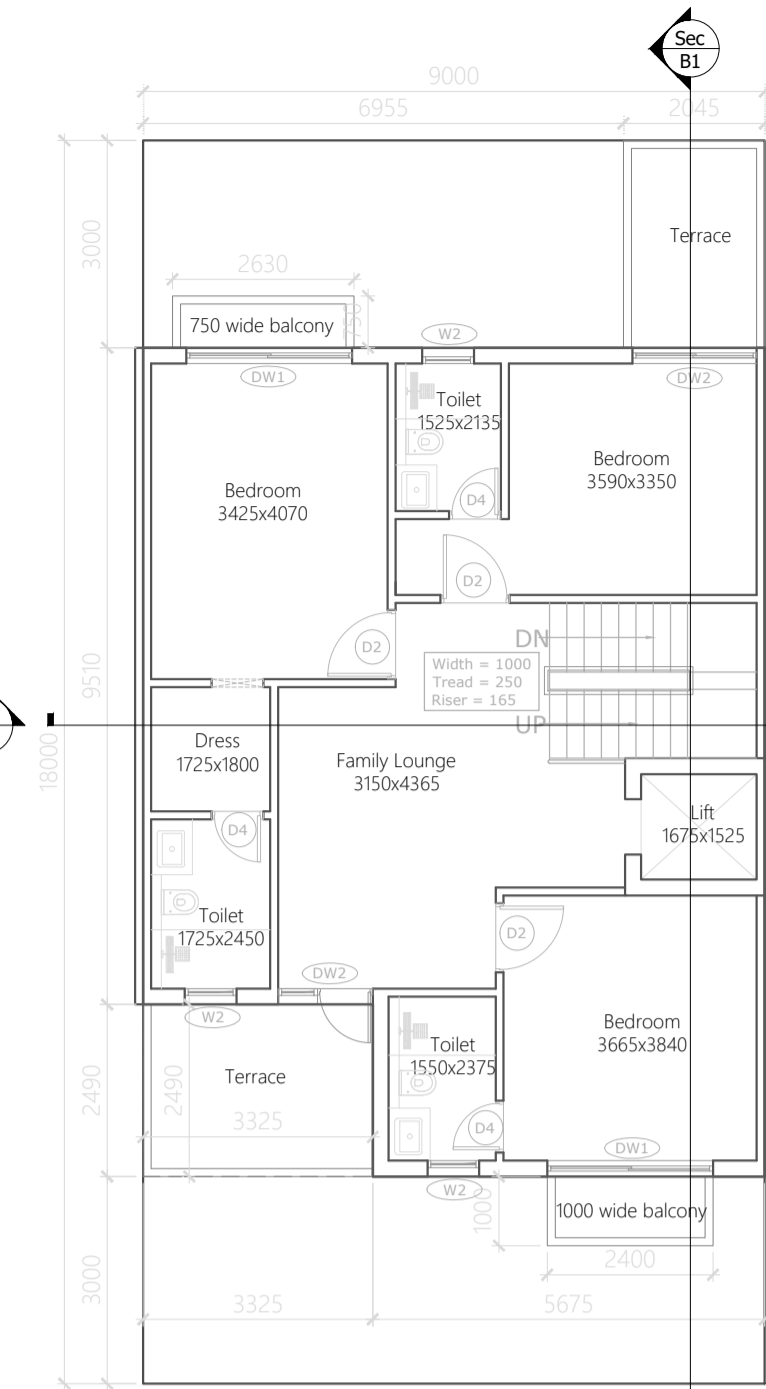

First Floor Plan
SCALE -1:100

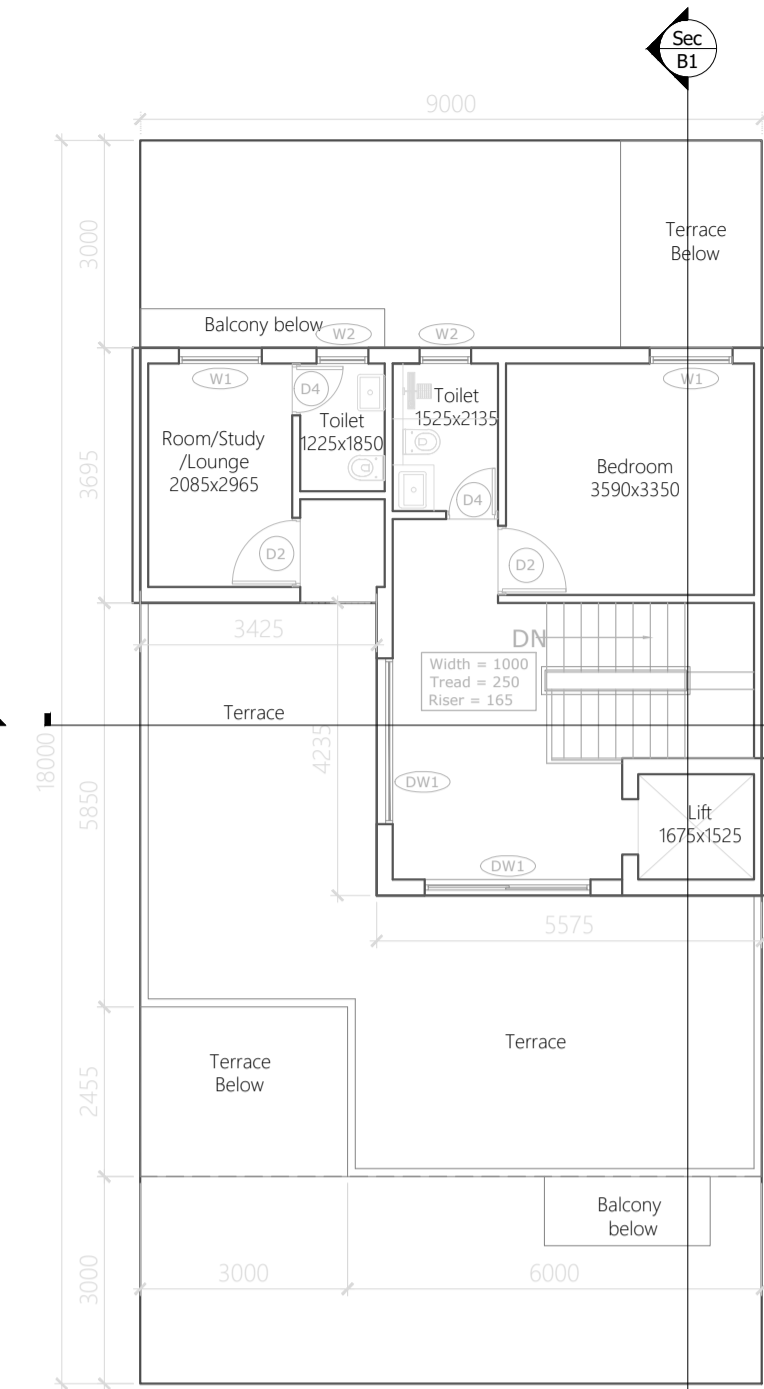

Second Floor Plan
SCALE -1:100

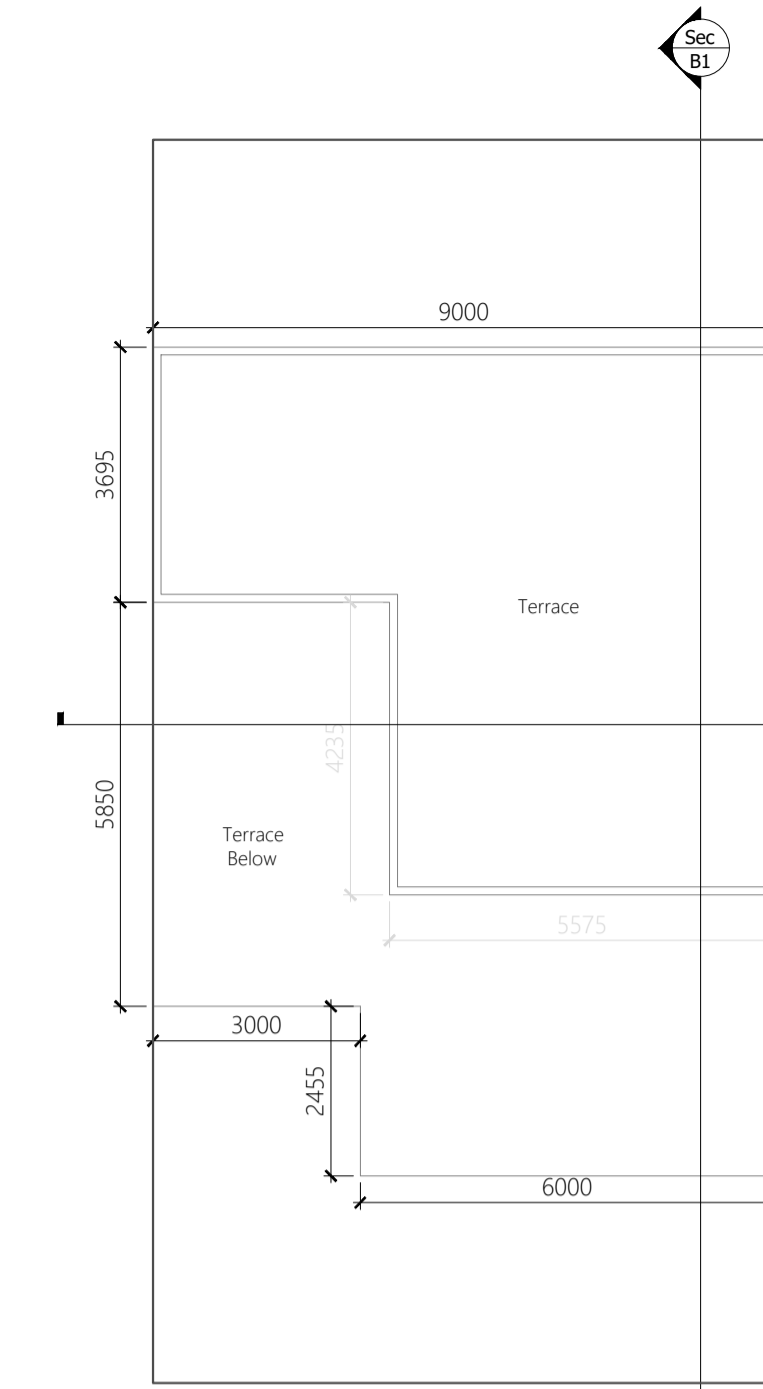

TERRACE Floor Plan
SCALE -1:100



Front Elevation
SCALE -1:100



Section-B1
SCALE -1:100

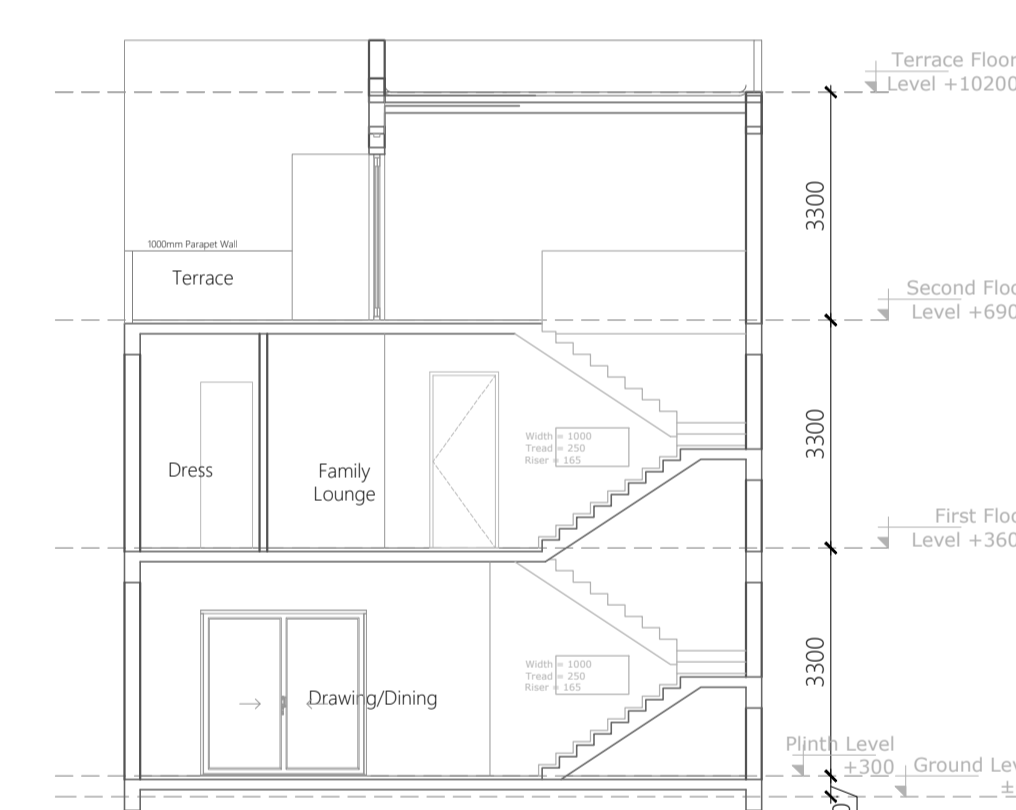

Section-A1
SCALE -1:100

Ground Floor Area Calculation				
Tag	Description	Size	Nos.	Area Sq. mtr.
1	Rectangle	2.045	3.000	6.135 Sq.mtr
2	Rectangle	9.000	10.100	90.900 Sq.mtr
3	Rectangle	3.935	1.990	7.831 Sq.mtr
Total				104.866 Sq.mtr

First Floor Area Calculation				
Tag	Description	Size	Nos.	Area Sq. mtr.
1	Rectangle	9.000	9.510	85.590 Sq.mtr
2	Rectangle	5.675	2.490	14.131 Sq.mtr
Total				99.721 Sq.mtr

Second Floor Area Calculation				
Tag	Description	Size	Nos.	Area Sq. mtr.
1	Rectangle	5.575	7.930	44.210 Sq.mtr
2	Rectangle	3.425	3.695	12.655 Sq.mtr
Total				56.865 Sq.mtr

NOTE :- ALL DIMENSIONS ARE IN MM

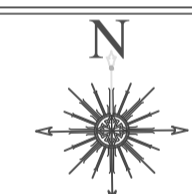

PROJECT ADDRESS:-

VILLA (9.0MX18.0M) IN
OMAXE HITECH CITY , LUCKNOW U.P.

OWNER NAME:-

OMAXE GARV BUILDTECH PVT LIMITED

This drawing is a "COPYRIGHT" contents of this drawing or part thereof may not be used or reproduced without the permission of the Architect

OWNER SIGNATURE



ARCHITECT SIGNATURE

Ar. Sachin Yadav
CA/2021/140419

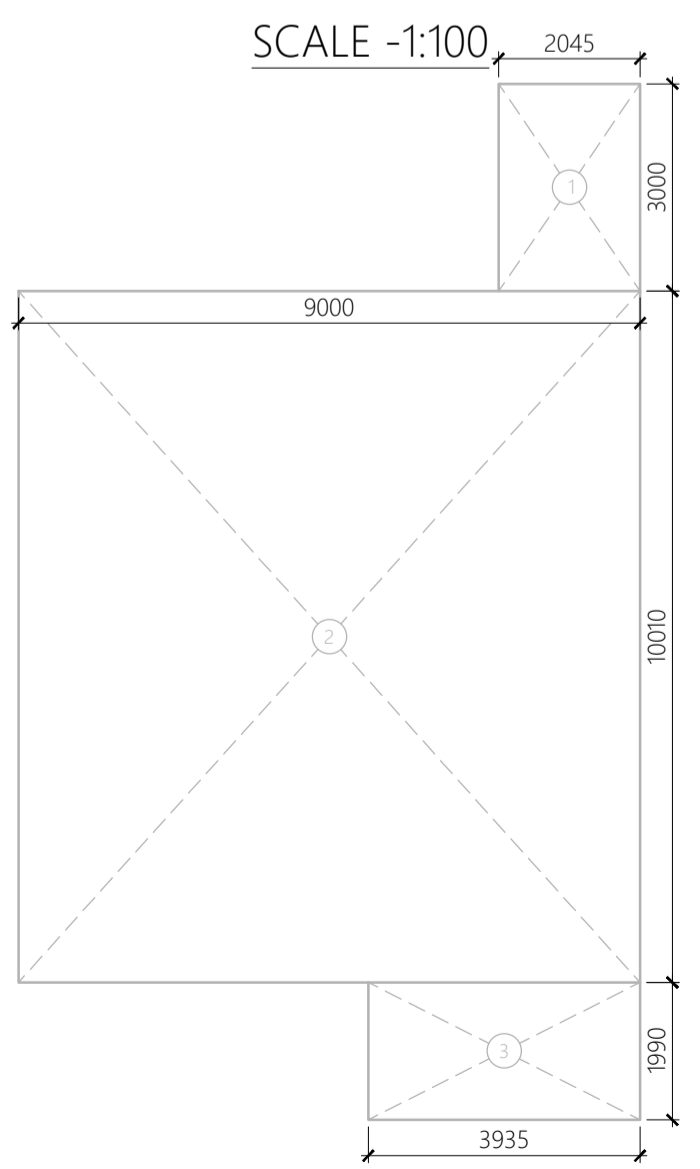

Area Envelope Plan of
Ground Floor

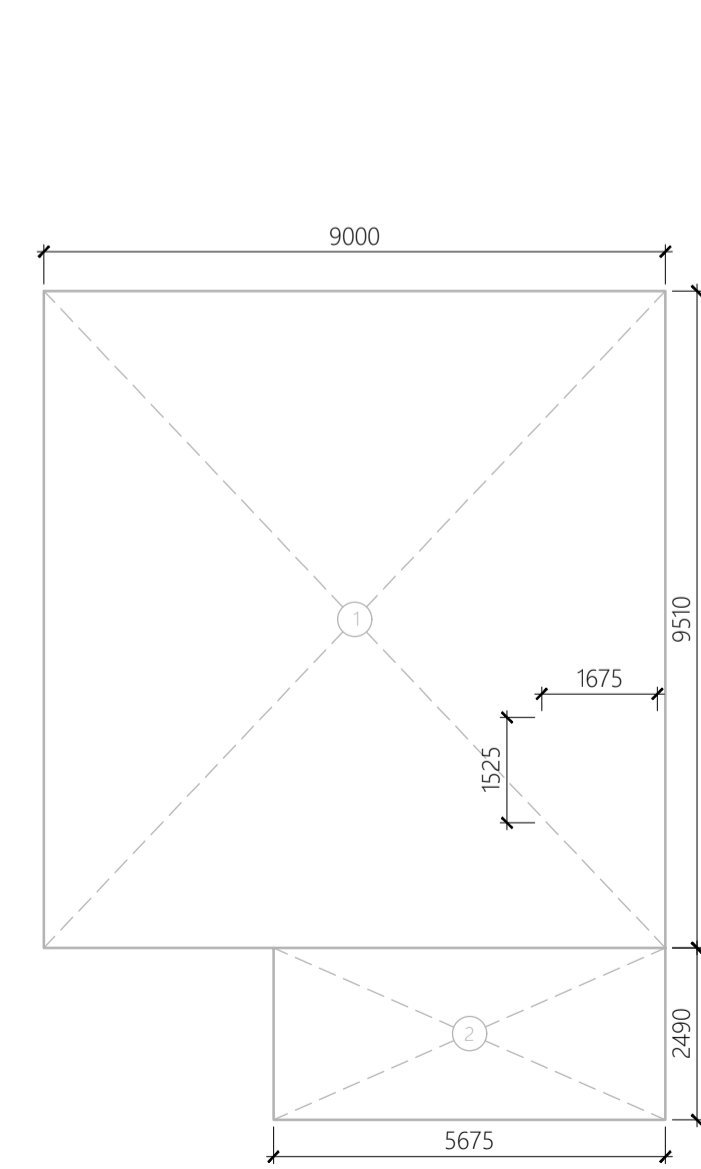

Area Envelope Plan of
First Floor

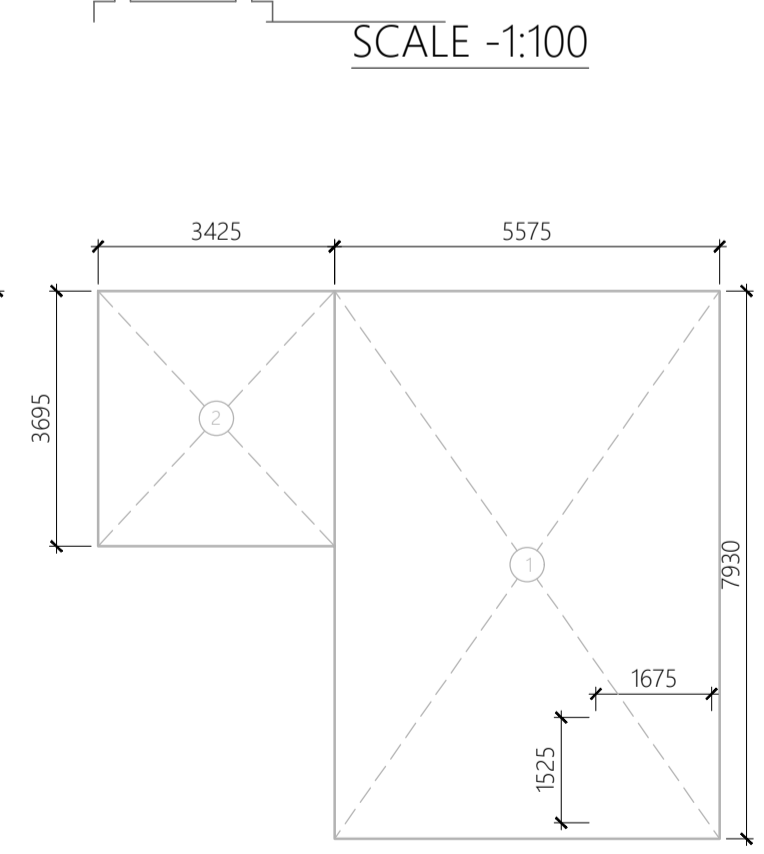

Area Envelope Plan of
Second Floor

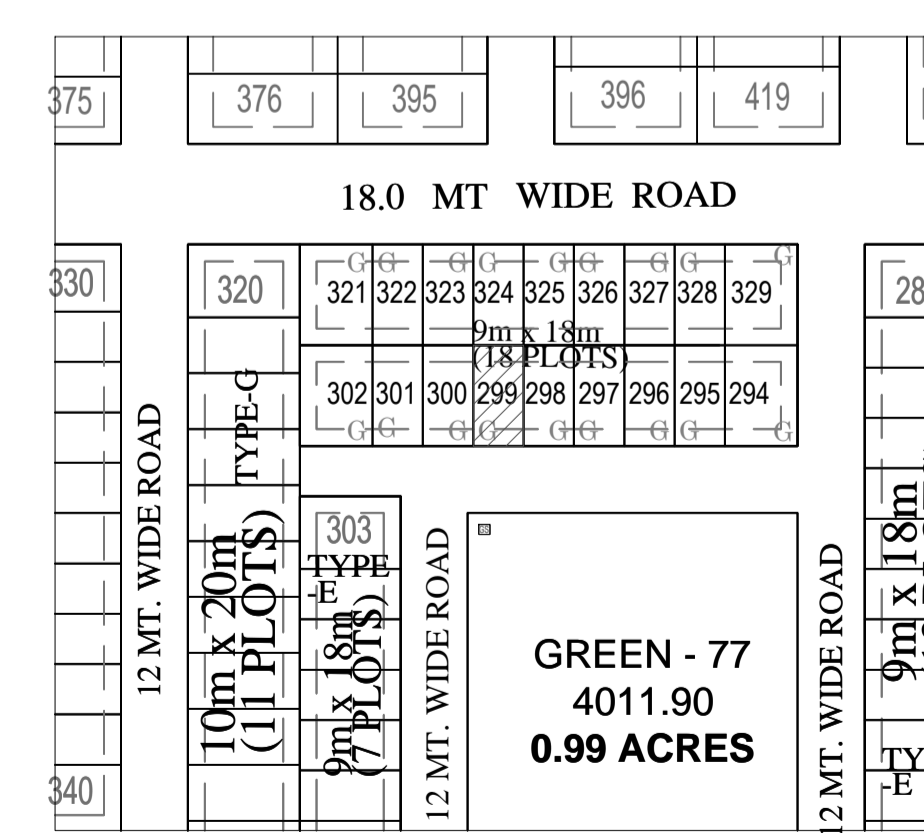

KEY PLAN
SCALE -1:100

DOOR - WINDOW SCHEDULE			
S. No.	Type	Size	Remark
1	DW1	2400x2400	Door/ Window
2	DW2	1800x2400	Door/ Window
3	DW2	1370x2400	Door/ Window
4	D1	1500x2400	Door
5	D2	1000x2400	Door
6	D3	900x2400	Door
7	D4	750x2400	Door
8	W1	1200x1500	Window
9	W2	750x1200	Window



FOR OFFICE :-

PROJECT TITLE-

PROPOSED RESIDENTIAL
SUBMISSION DRAWING FOR THE
VILLA ON PLOT NO - 323 P1
POCKET - L TYPE- E OMAXE HI-TECH
CITY AT LUCKNOW

AREA STATEMENT

S.NO.	PARTICULARS	SQ.MTR.
1.	PLOT AREA	162.0
2.	PERMISSIBLE GROUND FLOOR COVERAGE (65%)	105.300
3.	PROPOSED GROUND COVERAGE(64.19%)	104.00
4.	PROPOSED FIRST FLOOR AREA	97.166
5.	PROPOSED SECOND FLOOR AREA	56.865
6.	PROPOSED TERRACE FLOOR AREA	0.0
7.	PROPOSED PORCH AREA	10.08
8.	PERMISSIBLE F. A. R. (2.0)	324.00
9.	PROPOSED F. A. R. = [G.F. + F.F.+S.F](1.592)	258.031
10.	TOTAL COVERED AREA (3+4+5+6+7)	268.11

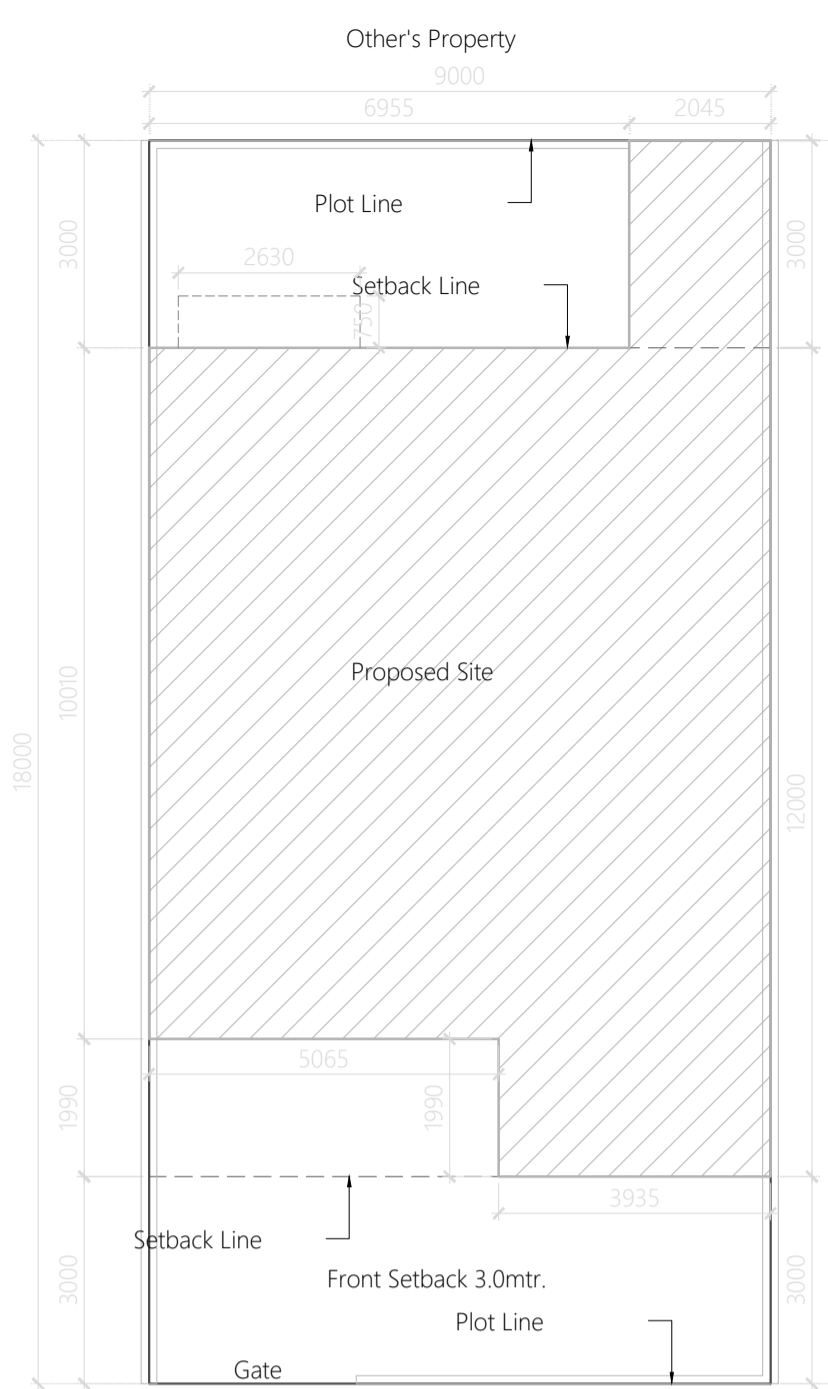

Site Plan
SCALE -1:100

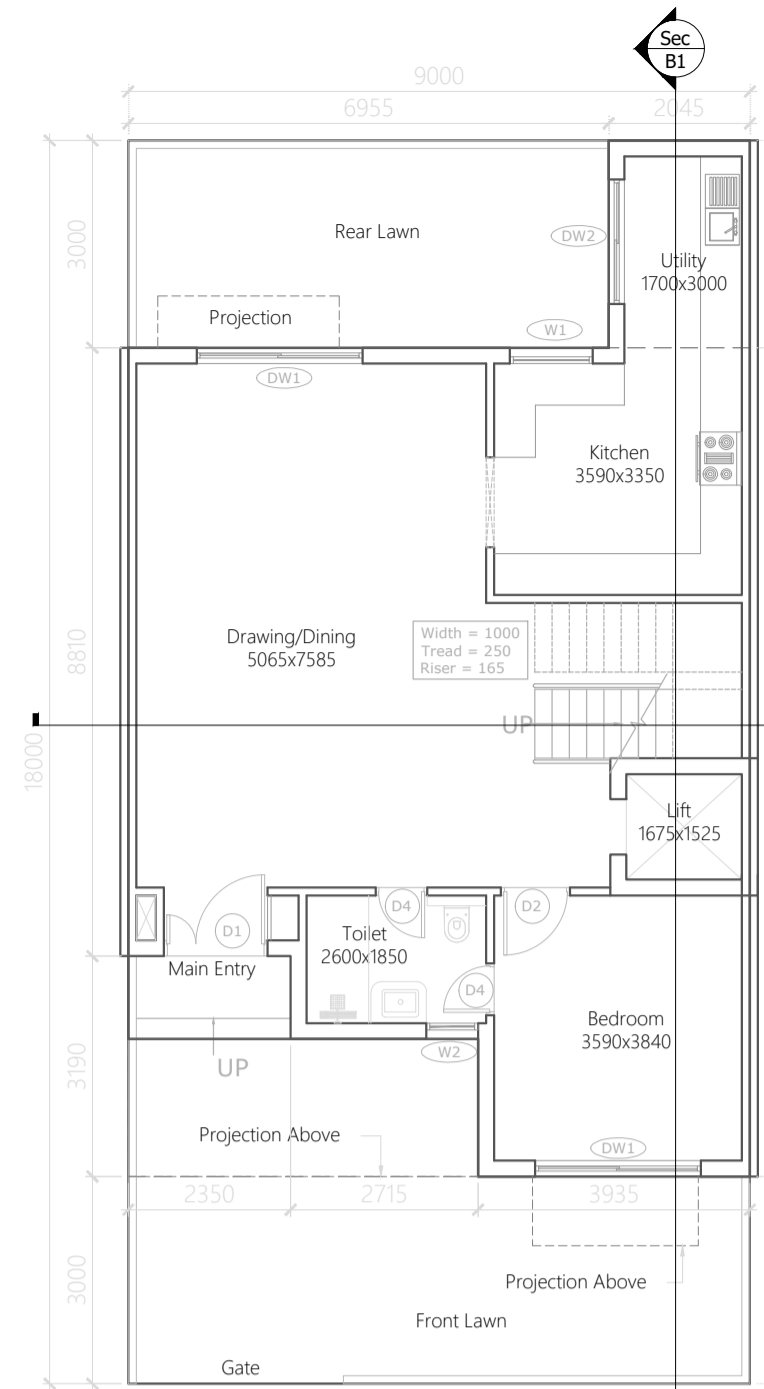

Ground Floor Plan
SCALE -1:100

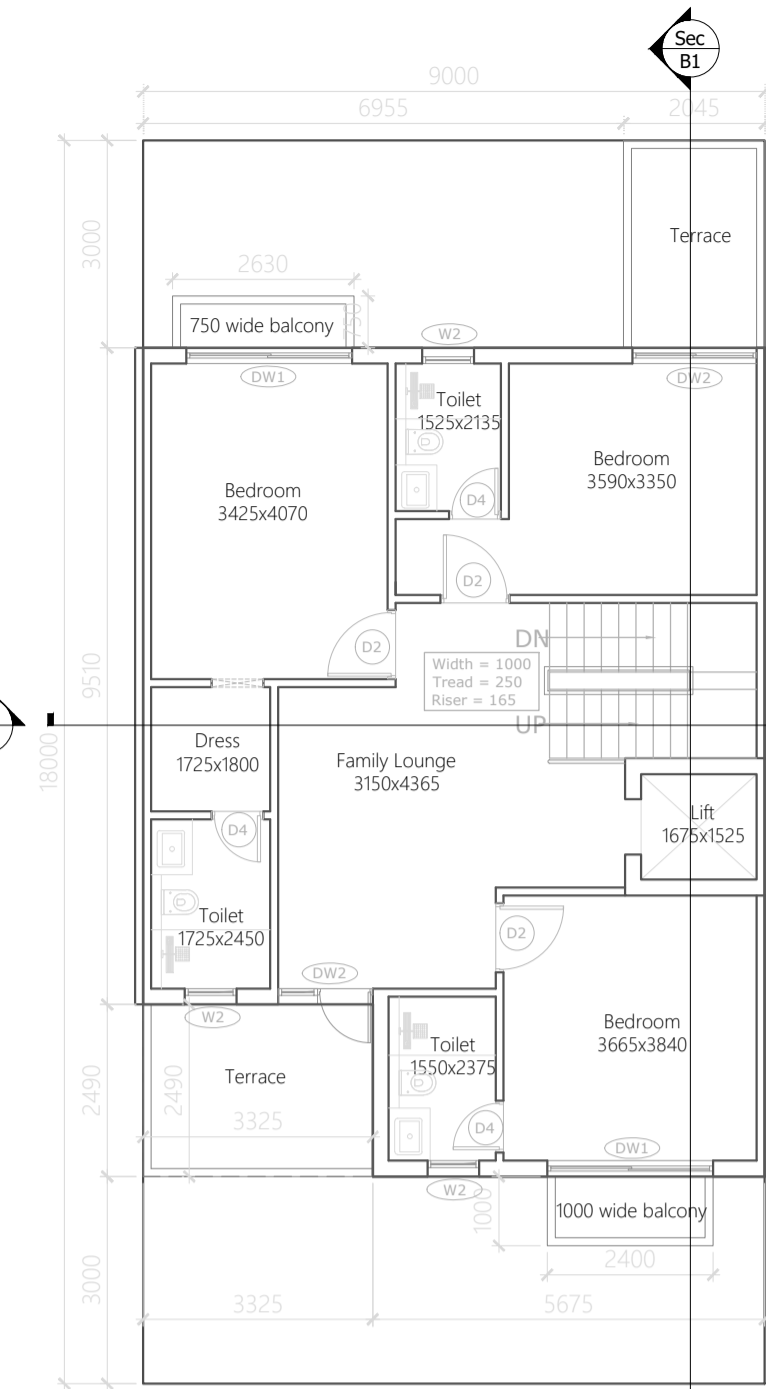

First Floor Plan
SCALE -1:100

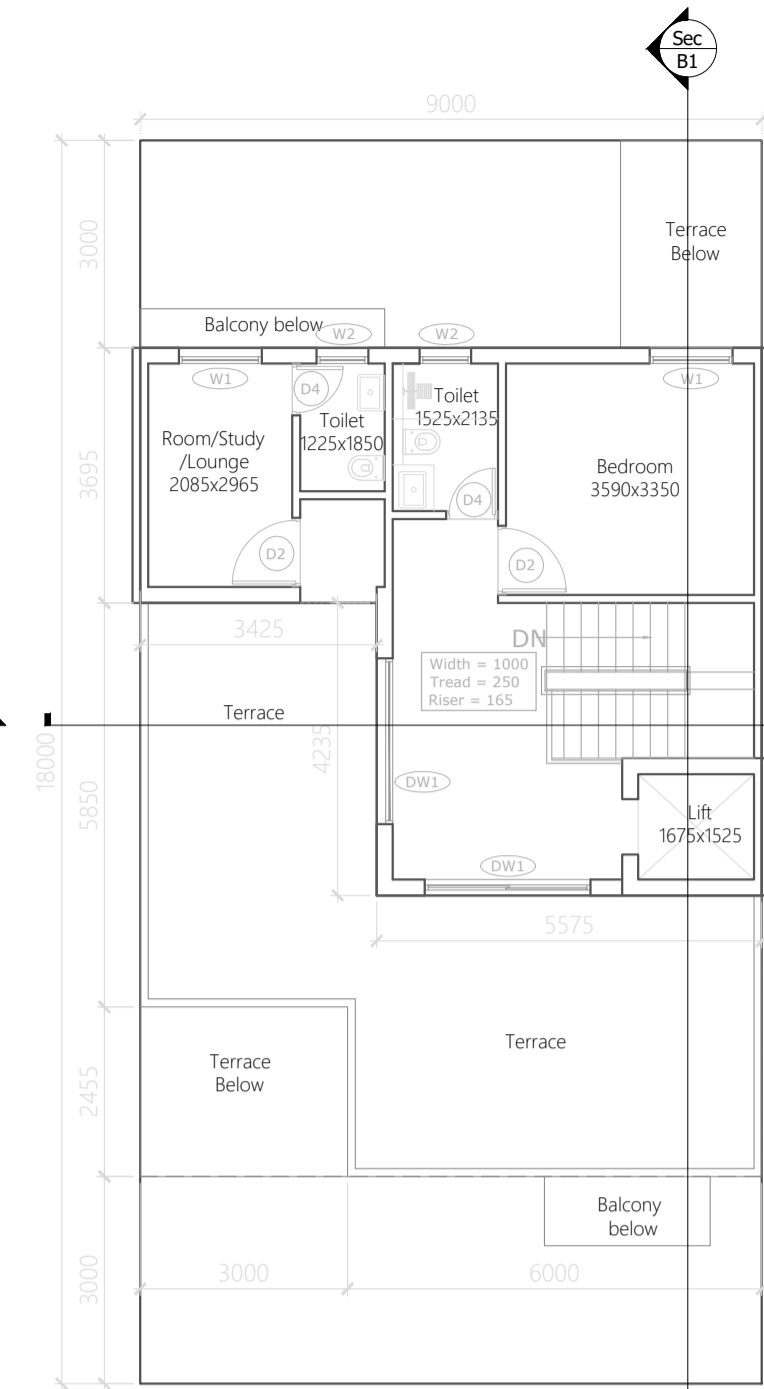

Second Floor Plan
SCALE -1:100

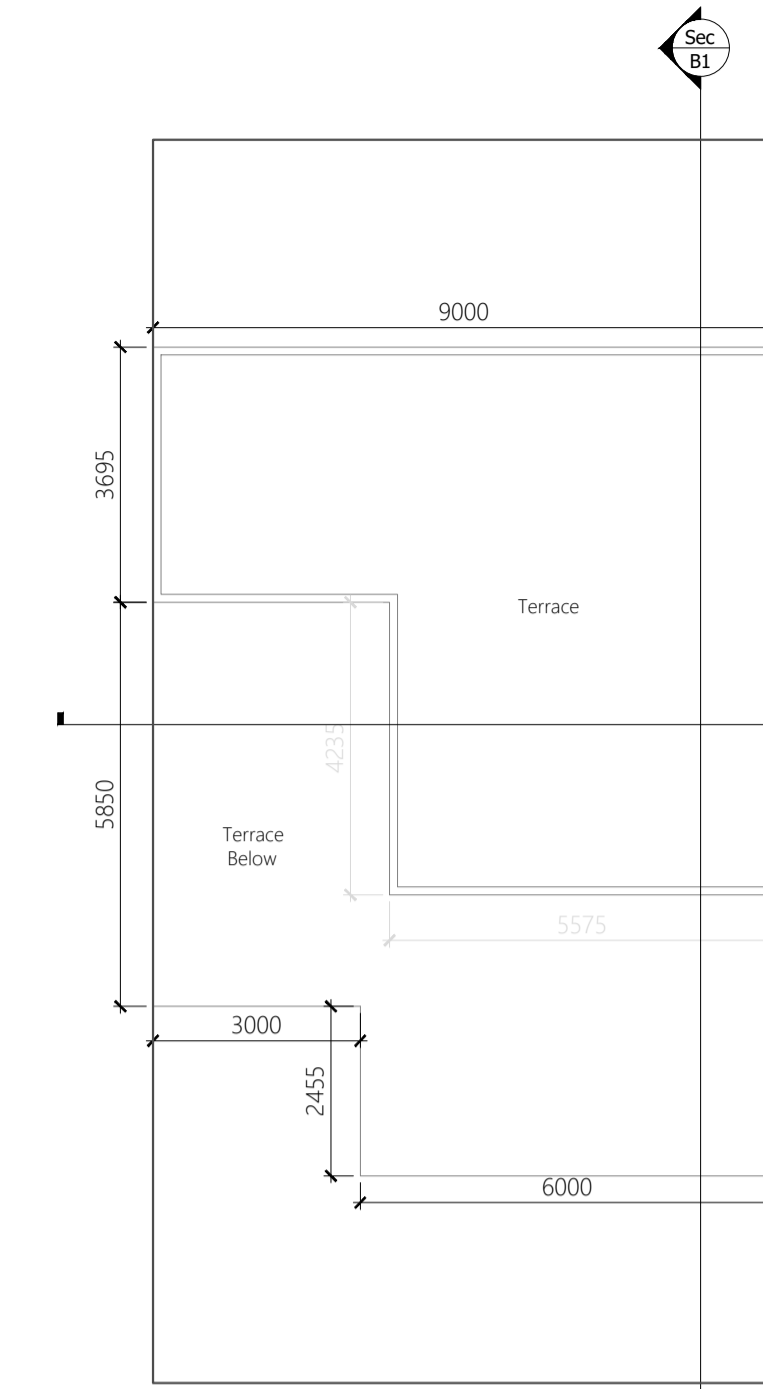

TERRACE Floor Plan
SCALE -1:100



Front Elevation
SCALE -1:100



Section-B1
SCALE -1:100

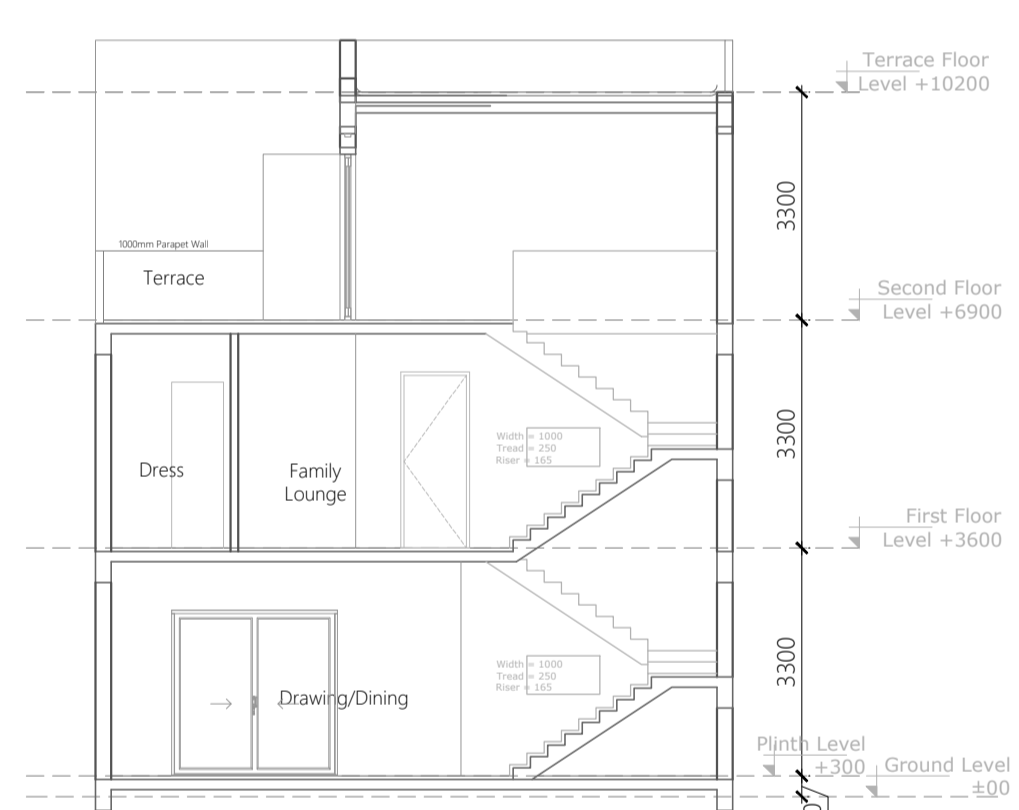

Section-A1
SCALE -1:100

Tag	Description	Size	Nos.	Area Sq.mtr.	Remark
1	Rectangle	2.045	3.000	6.135	Sq.mtr
2	Rectangle	9.000	10.100	90.900	Sq.mtr
3	Rectangle	3.935	1.990	7.831	Sq.mtr
Total				104.866	Sq.mtr X1

Tag	Description	Size	Nos.	Area Sq.mtr.	Remark
1	Rectangle	9.000	9.510	85.590	Sq.mtr
2	Rectangle	5.675	2.490	14.131	Sq.mtr
Total				99.721	Sq.mtr X1

Tag	Description	Size	Nos.	Area Sq.mtr.	Remark
1	Rectangle	5.575	7.930	44.210	Sq.mtr
2	Rectangle	3.425	3.695	12.655	Sq.mtr
Total				56.865	Sq.mtr X1

NOTE :- ALL DIMENSIONS ARE IN MM

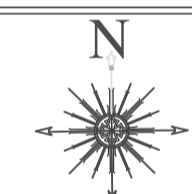

PROJECT ADDRESS:-

VILLA (9.0MX18.0M) IN
OMAXE HITECH CITY , LUCKNOW U.P.

OWNER NAME:-

OMAXE GARV BUILDTECH PVT LIMITED

This drawing is a "COPYRIGHT" contents of this drawing or part thereof may not be used or reproduced without the permission of the Architect

OWNER SIGNATURE



ARCHITECT SIGNATURE

Ar. Sachin Yadav
CA/2021/140419

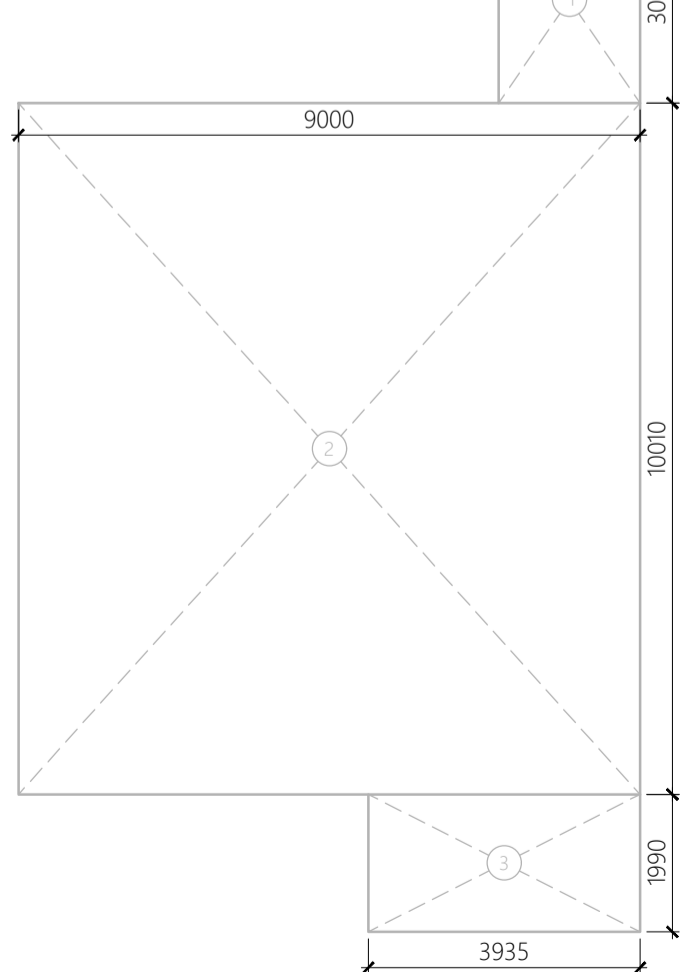

Area Envelope Plan of
Ground Floor

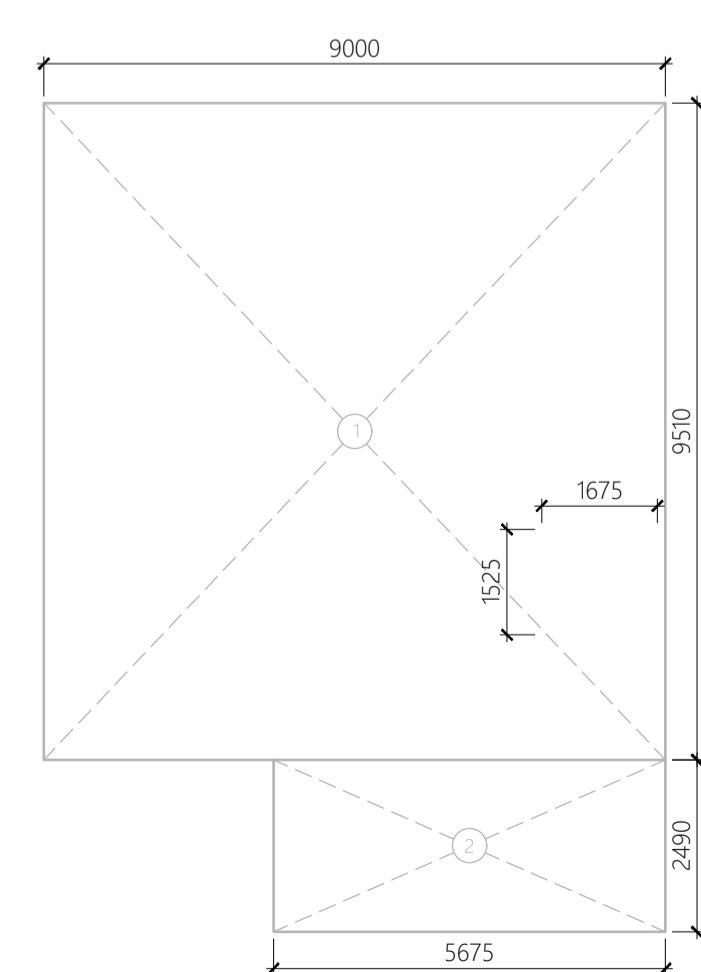

Area Envelope Plan of
First Floor

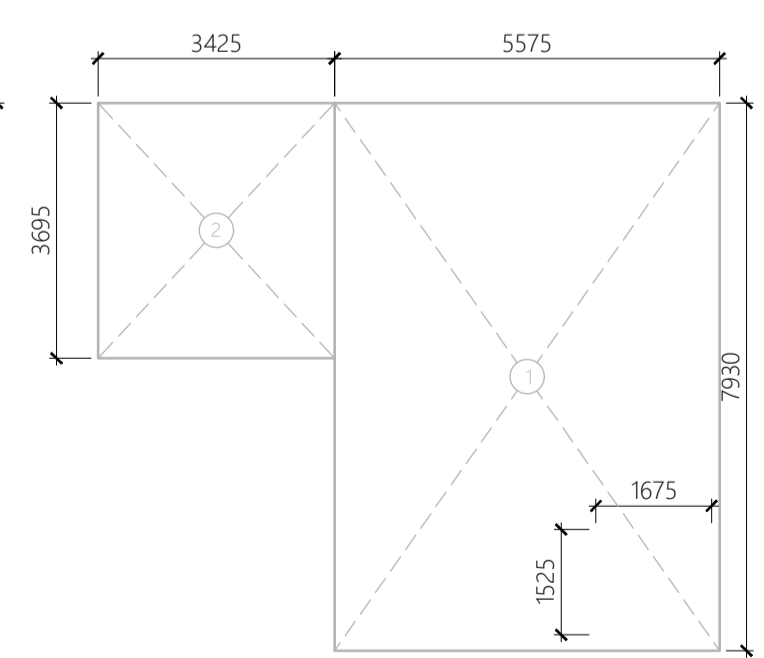

Area Envelope Plan of
Second Floor

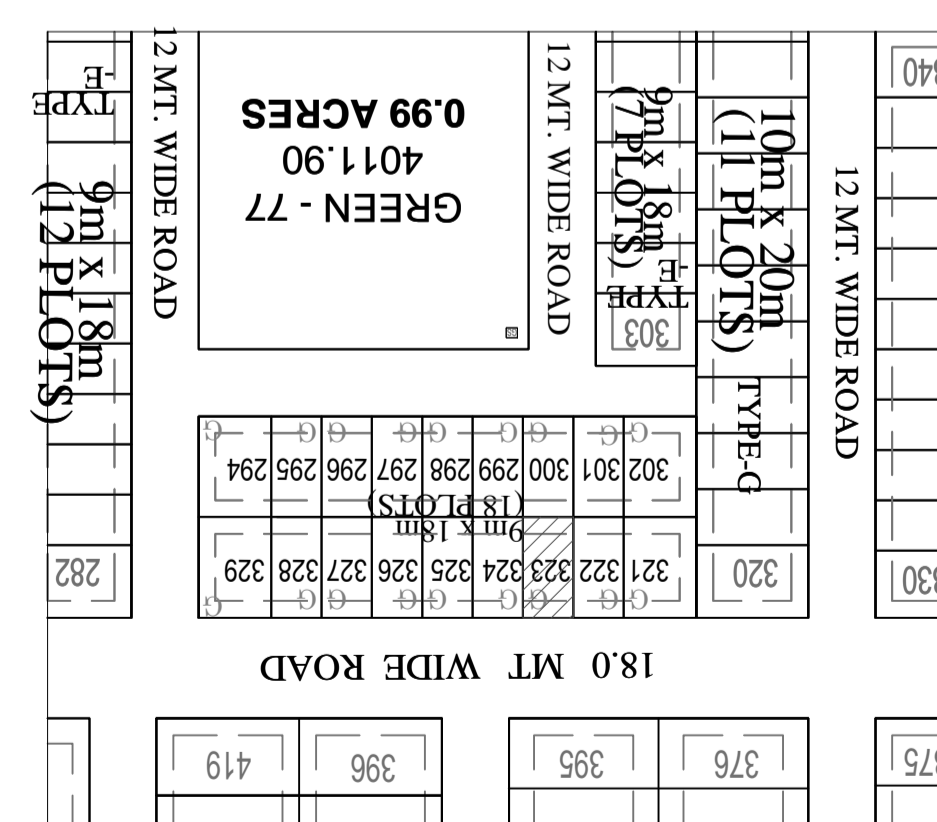

KEY PLAN
SCALE -1:100

S. No.	Type	Size	Remark
1	DW1	2400x2400	Door/ Window
2	DW2	1800x2400	Door/ Window
3	DW2	1370x2400	Door/ Window
4	D1	1500x2400	Door
5	D2	1000x2400	Door
6	D3	900x2400	Door
7	D4	750x2400	Door
8	W1	1200x1500	Window
9	W2	750x1200	Window



FOR OFFICE :-

PROJECT TITLE-

**PROPOSED RESIDENTIAL
SUBMISSION DRAWING FOR THE
VILLA ON PLOT NO - 324 P1
POCKET - L TYPE- E OMAXE
HI-TECH CITY AT LUCKNOW**

AREA STATEMENT

S.NO.	PARTICULARS	SQ.MTR.
1.	PLOT AREA	162.0
2.	PERMISSIBLE GROUND FLOOR COVERAGE (65%)	105.300
3.	PROPOSED GROUND COVERAGE(64.19%)	104.00
4.	PROPOSED FIRST FLOOR AREA	97.166
5.	PROPOSED SECOND FLOOR AREA	56.865
6.	PROPOSED TERRACE FLOOR AREA	0.0
7.	PROPOSED PORCH AREA	10.08
8.	PERMISSIBLE F. A. R. (2.0)	324.00
9.	PROPOSED F. A. R. = [G.F. + F.F.+S.F.](1.592)	258.031
10.	TOTAL COVERED AREA (3+4+5+6+7)	268.11

NOTE :- ALL DIMENSIONS ARE IN MM

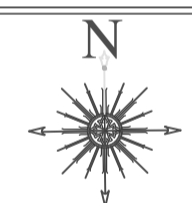

PROJECT ADDRESS:-

**VILLA (9.0MX18.0M) IN
OMAXE HITECH CITY , LUCKNOW U.P.**

OWNER NAME:-

OMAXE GARV BUILDTech PVT LIMITED

This drawing is a "COPYRIGHT" contents of this drawing or part thereof may not be used or reproduced without the permission of the Architect

OWNER SIGNATURE



ARCHITECT SIGNATURE

Sachin Yadav
Ar. Sachin Yadav
CA/2021/140419

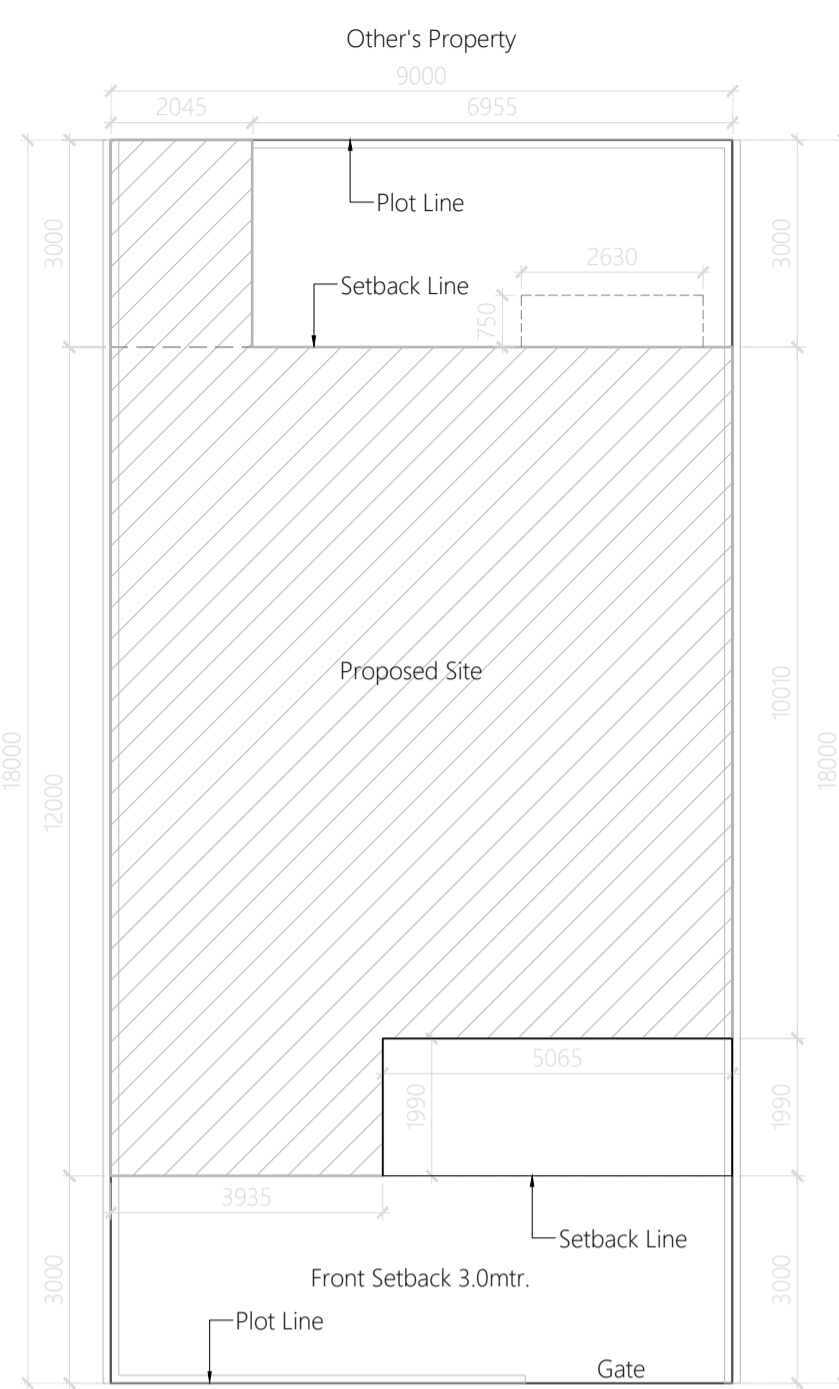

Site Plan
SCALE -1:100

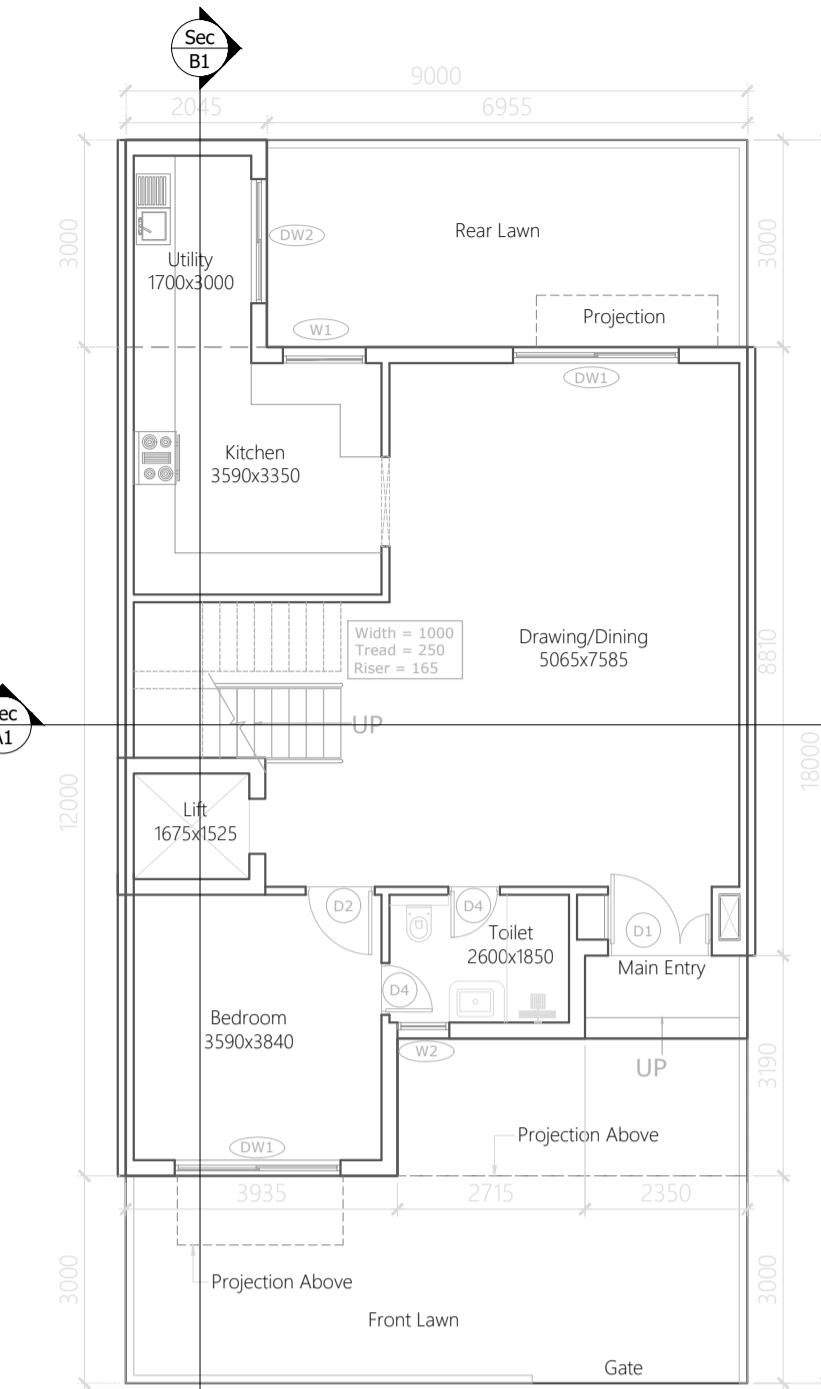

Ground Floor Plan
SCALE -1:100

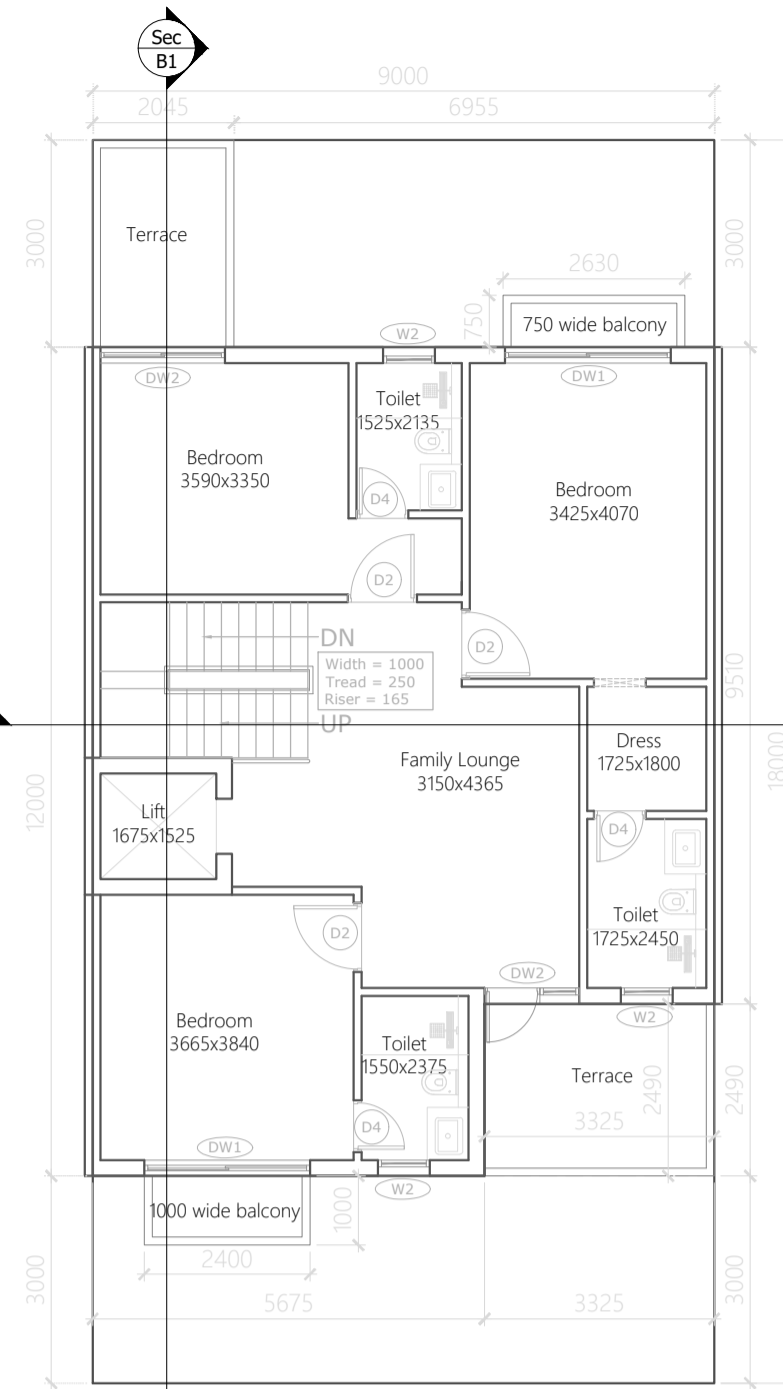

First Floor Plan
SCALE -1:100

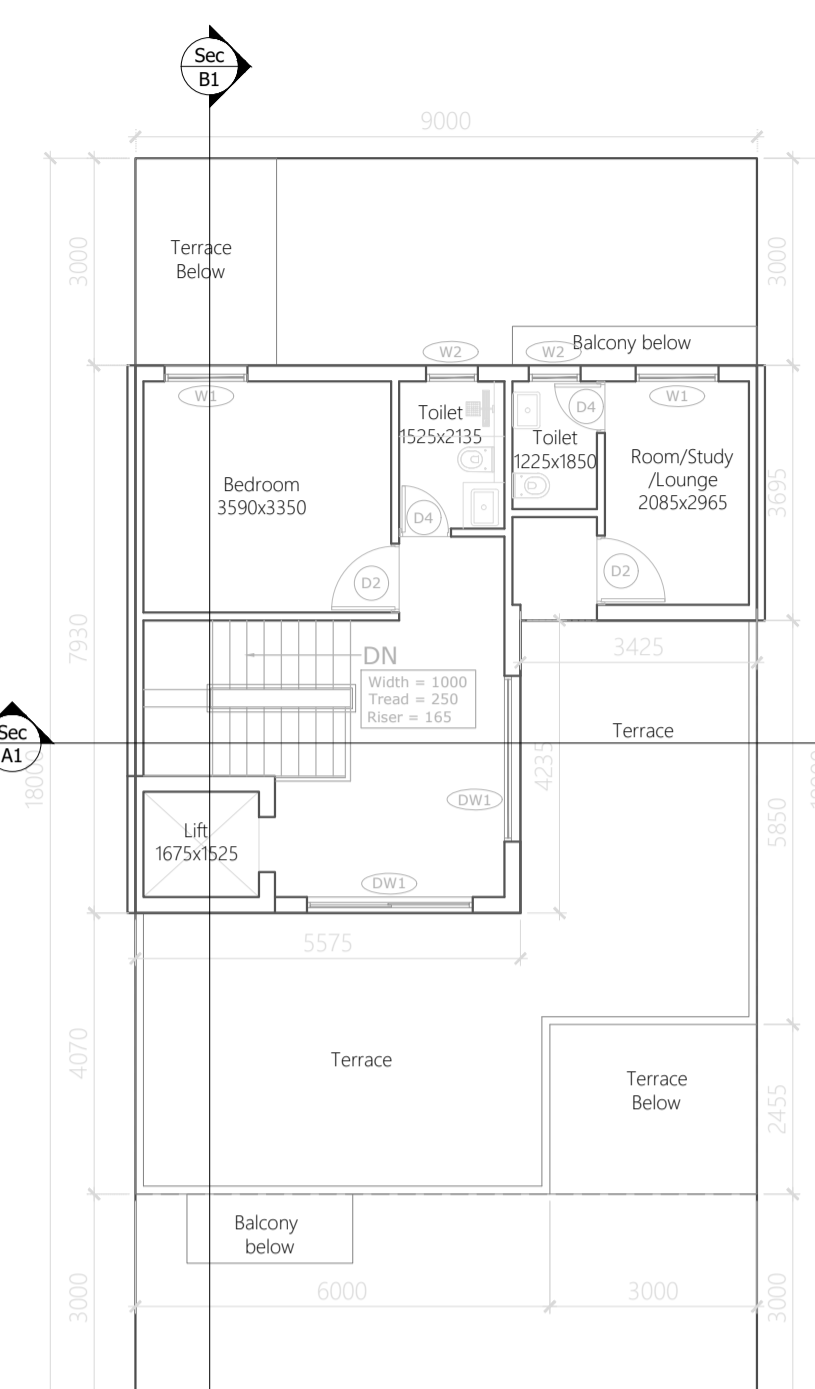

Second Floor Plan
SCALE -1:100

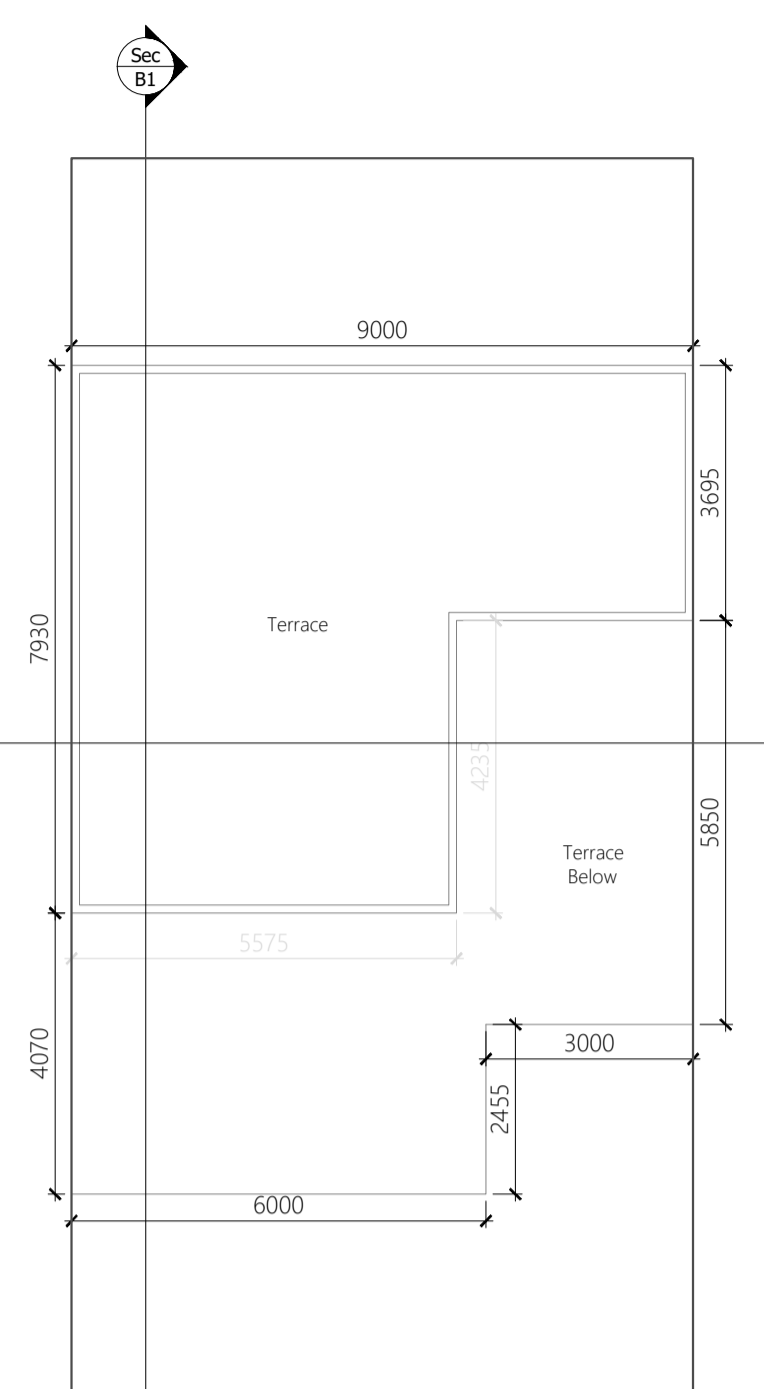

TERRACE Floor Plan
SCALE -1:100



Front Elevation
SCALE -1:100



Section-B1
SCALE -1:100

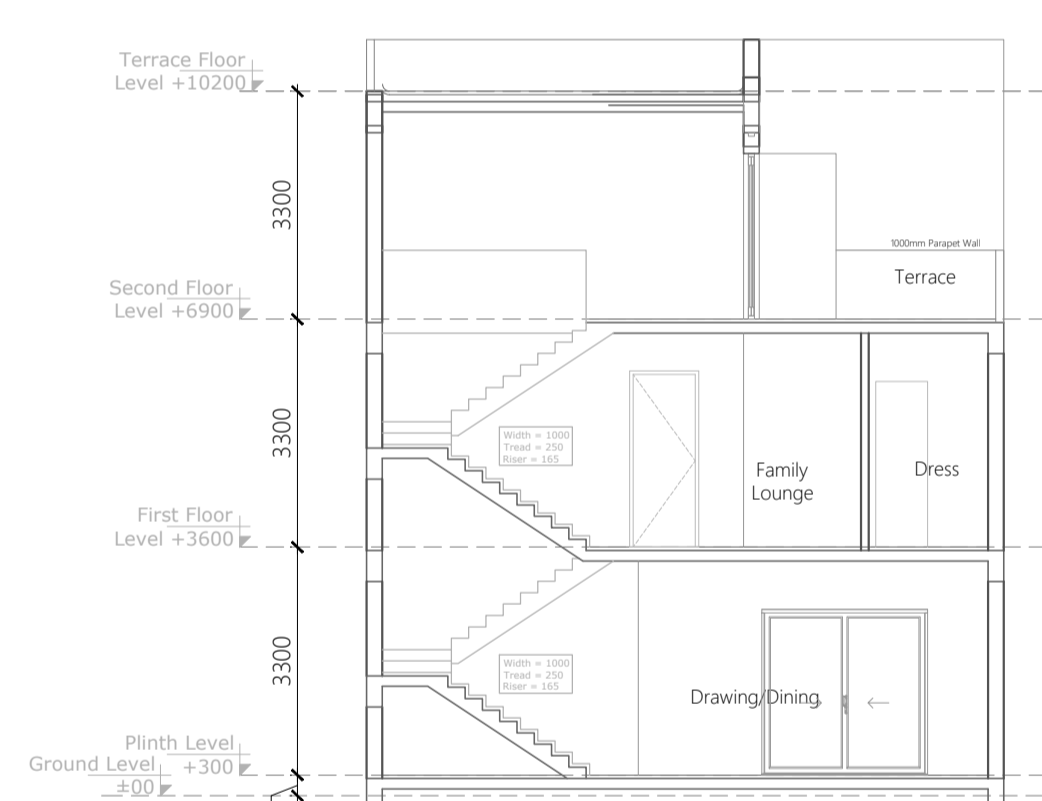

Section-A1
SCALE -1:100

Ground Floor Area Calculation

Tag	Description	Size	No.	Area Sq.mtr.	Remark
1	Rectangle	2.045 x 3.000	1	6.135	Sq.mtr.
2	Rectangle	3.000 x 3.000	1	9.000	Sq.mtr.
3	Rectangle	3.025 x 3.000	1	9.075	Sq.mtr.
Total				15.210	Sq.mtr.

First Floor Area Calculation

Tag	Description	Size	No.	Area Sq.mtr.	Remark
1	Rectangle	3.000 x 2.400	1	7.200	Sq.mtr.
2	Rectangle	3.025 x 2.400	1	7.260	Sq.mtr.
Total				14.460	Sq.mtr.

Second Floor Area Calculation

Tag	Description	Size	No.	Area Sq.mtr.	Remark
1	Rectangle	3.025 x 3.025	1	9.151	Sq.mtr.
2	Rectangle	3.025 x 3.025	1	9.151	Sq.mtr.
Total				18.302	Sq.mtr.

Area For Deduction

Tag	Description	Size	No.	Area Sq.mtr.	Remark
1	Rectangle	3.025 x 3.025	1	9.151	Sq.mtr.
Total				9.151	Sq.mtr.

Total F.A.R. Area at Ground Floor (G.F.)

Tag	Description	Size	No.	Area Sq.mtr.	Remark
1	Rectangle	3.025 x 3.025	1	9.151	Sq.mtr.
2	Rectangle	3.025 x 3.025	1	9.151	Sq.mtr.
Total				18.302	Sq.mtr.

Total F.A.R. Area at First Floor (F.F.)

Tag	Description	Size	No.	Area Sq.mtr.	Remark
1	Rectangle	3.025 x 3.025	1	9.151	Sq.mtr.
2	Rectangle	3.025 x 3.025	1	9.151	Sq.mtr.
Total				18.302	Sq.mtr.

Total F.A.R. Area at Second Floor (S.F.)

Tag	Description	Size	No.	Area Sq.mtr.	Remark
1	Rectangle	3.025 x 3.025	1	9.151	Sq.mtr.
2	Rectangle	3.025 x 3.025	1	9.151	Sq.mtr.
Total				18.302	Sq.mtr.

DOOR - WINDOW SCHEDULE

S. No.	Type	Size	Remark
1	DW1	2400x2400	Door/ Window
2	DW2	1800x2400	Door/ Window
3	DW2	1370x2400	Door/ Window
4	D1	1500x2400	Door
5	D2	1000x2400	Door
6	D3	900x2400	Door
7	D4	750x2400	Door
8	W1	1200x1500	Window
9	W2	750x1200	Window

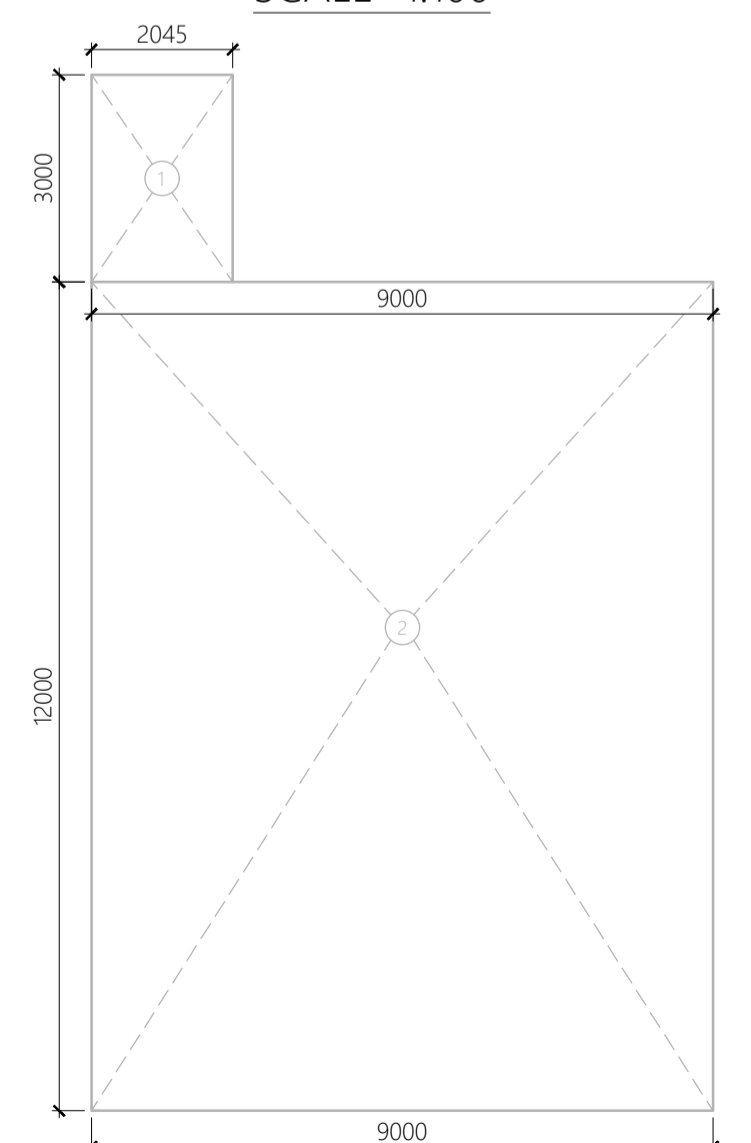

Area Envelope Plan of
Ground Floor

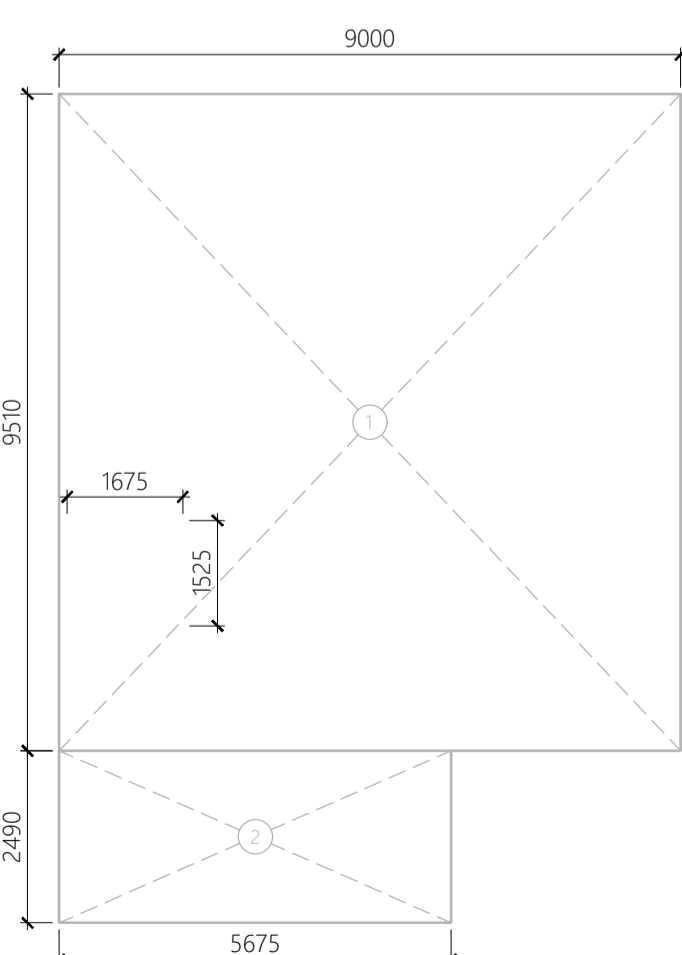

Area Envelope Plan of
First Floor

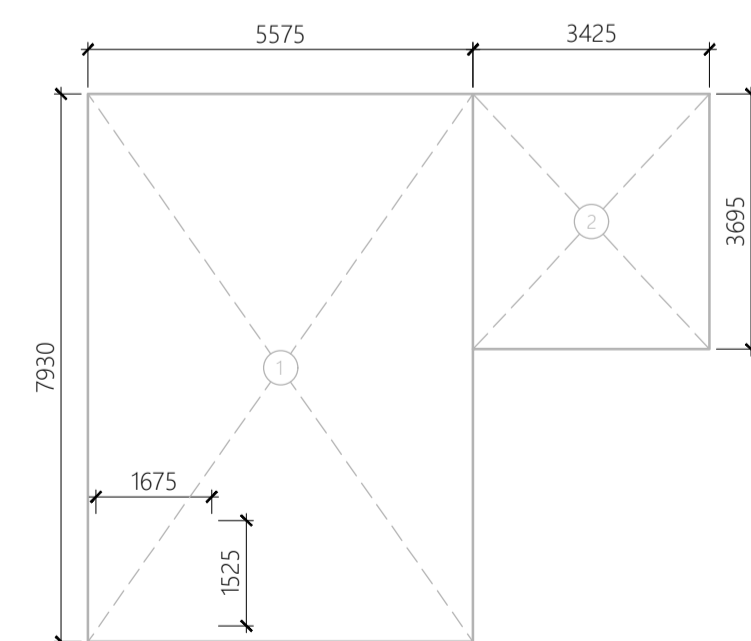

Area Envelope Plan of
Second Floor

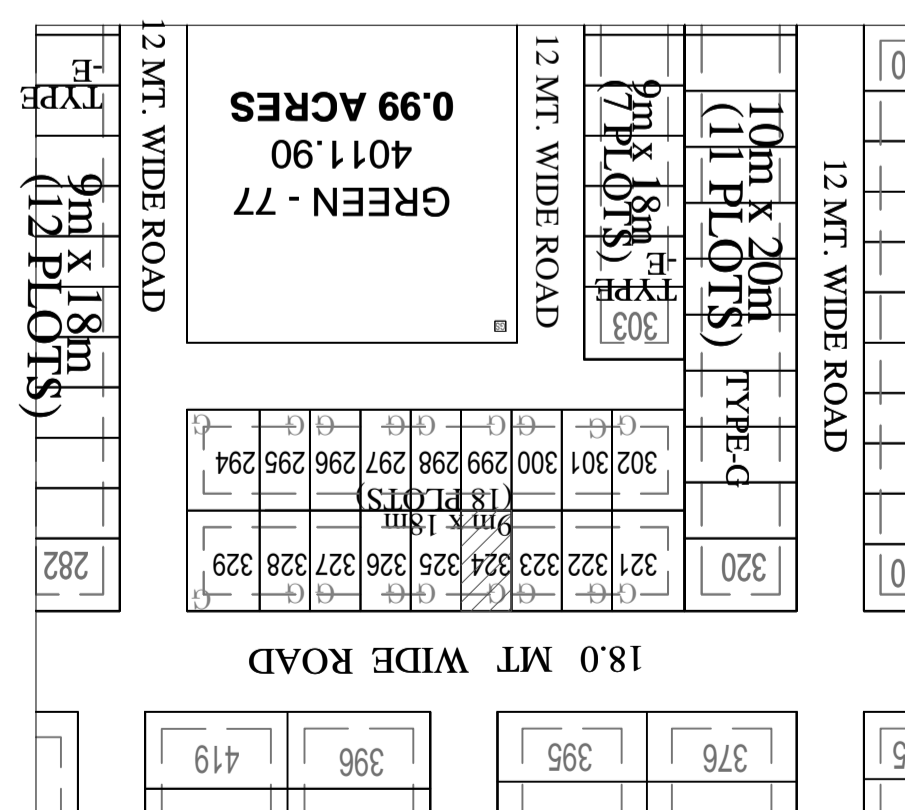

KEY PLAN
SCALE -1:100



Lucknow Development Authority

FOR OFFICE :-

PROJECT TITLE-

PROPOSED RESIDENTIAL
SUBMISSION DRAWING FOR THE
VILLA ON PLOT NO - 325 P1
POCKET - L TYPE- E OMAXE HI-TECH
CITY AT LUCKNOW

AREA STATEMENT

S.NO.	PARTICULARS	SQ.MTR.
1.	PLOT AREA	162.0
2.	PERMISSIBLE GROUND FLOOR COVERAGE (65%)	105.300
3.	PROPOSED GROUND COVERAGE(64.19%)	104.00
4.	PROPOSED FIRST FLOOR AREA	97.166
5.	PROPOSED SECOND FLOOR AREA	56.865
6.	PROPOSED TERRACE FLOOR AREA	0.0
7.	PROPOSED PORCH AREA	10.08
8.	PERMISSIBLE F. A. R. (2.0)	324.00
9.	PROPOSED F. A. R. = [G.F. + F.F.+S.F](1.592)	258.031
10.	TOTAL COVERED AREA (3+4+5+6+7)	268.11

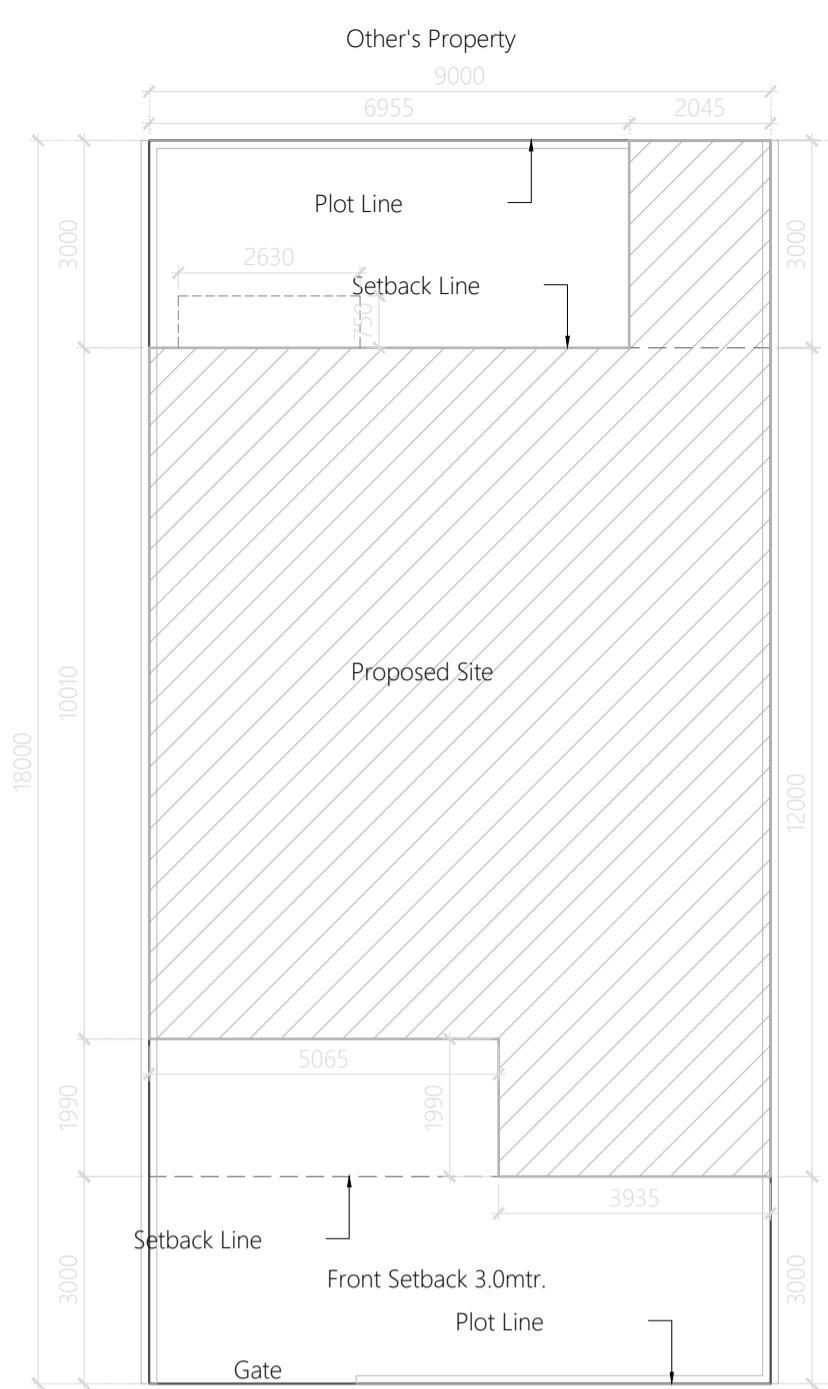

Site Plan
SCALE -1:100

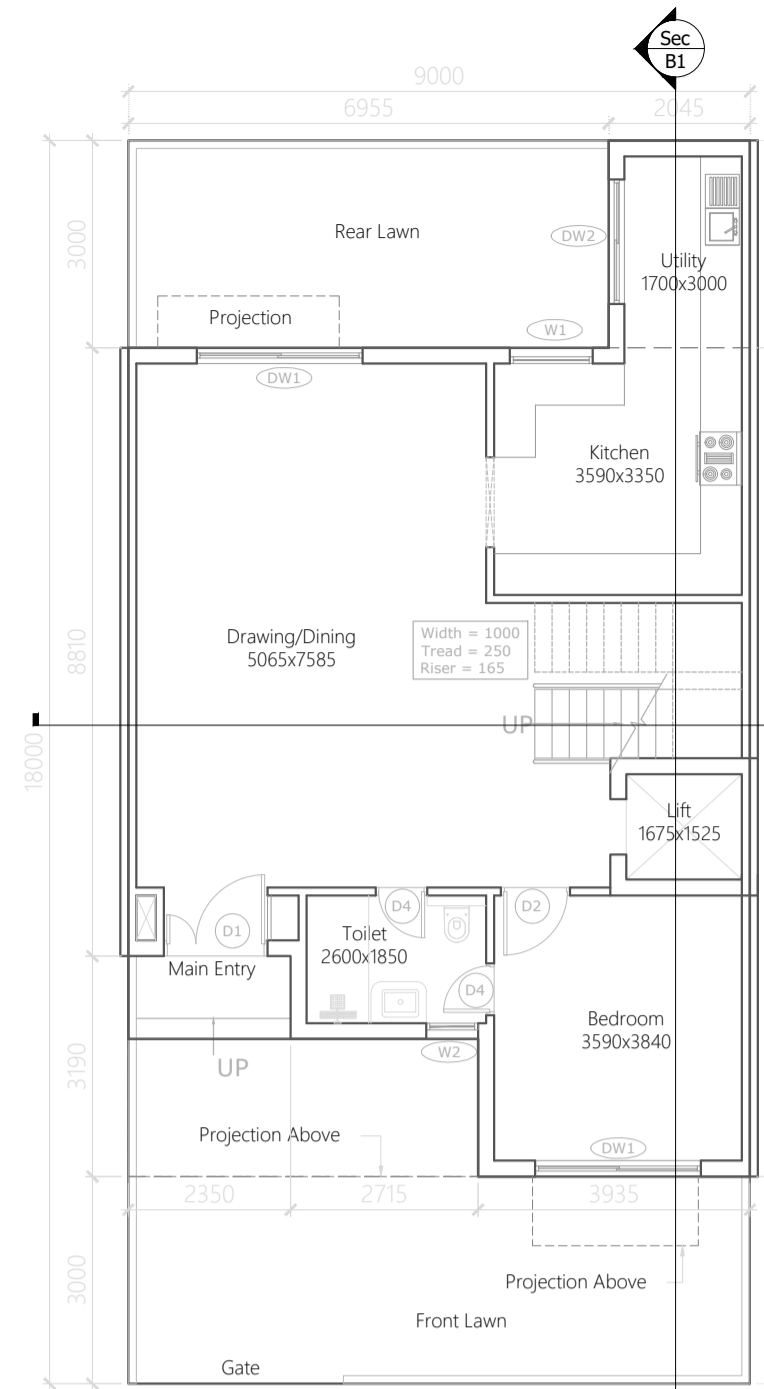

Ground Floor Plan
SCALE -1:100

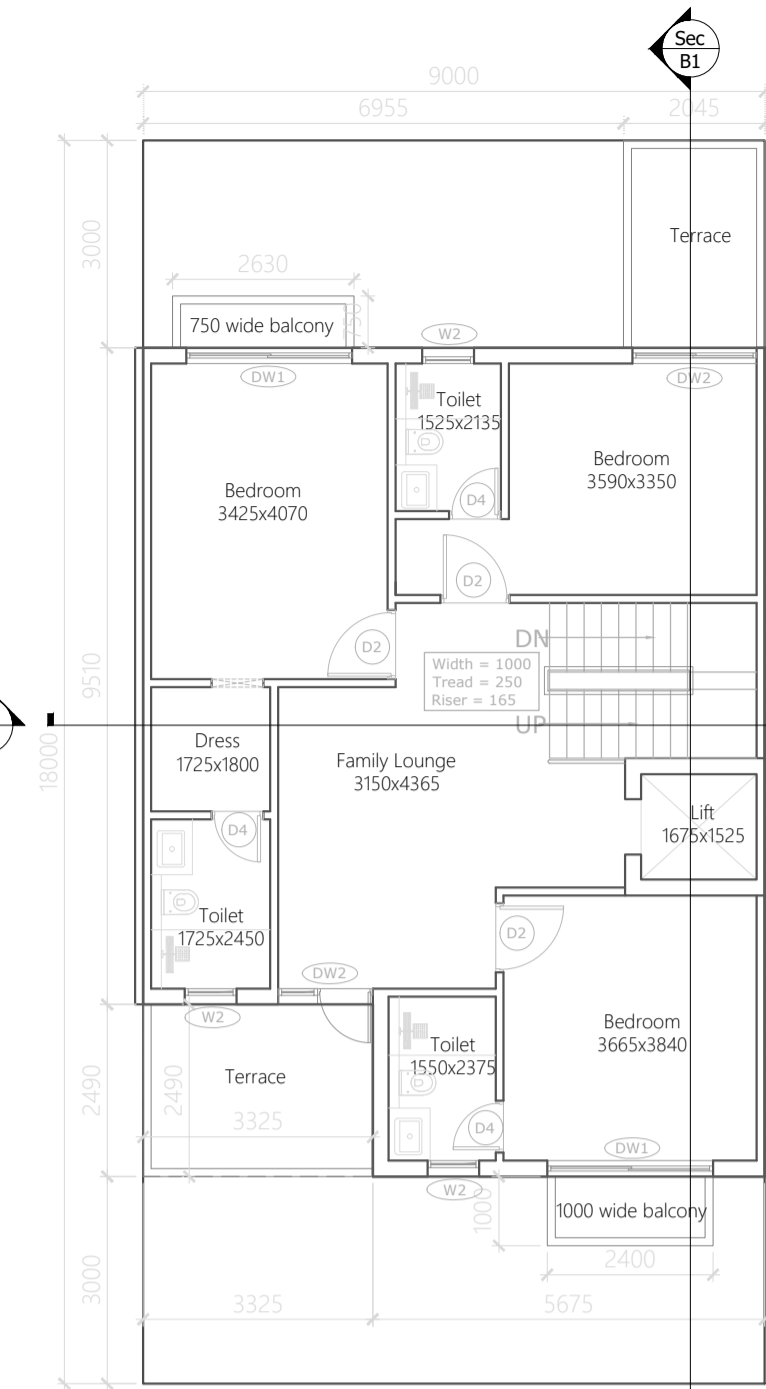

First Floor Plan
SCALE -1:100

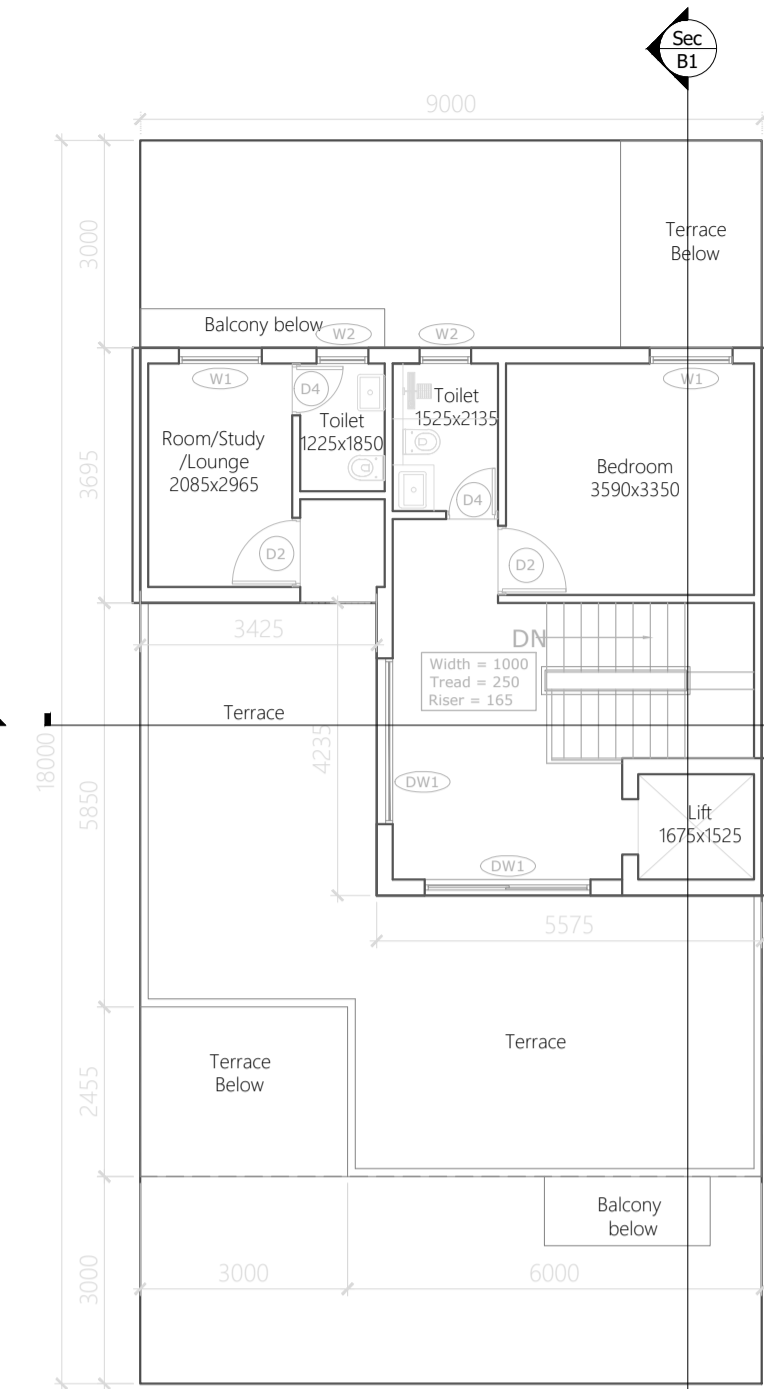

Second Floor Plan
SCALE -1:100

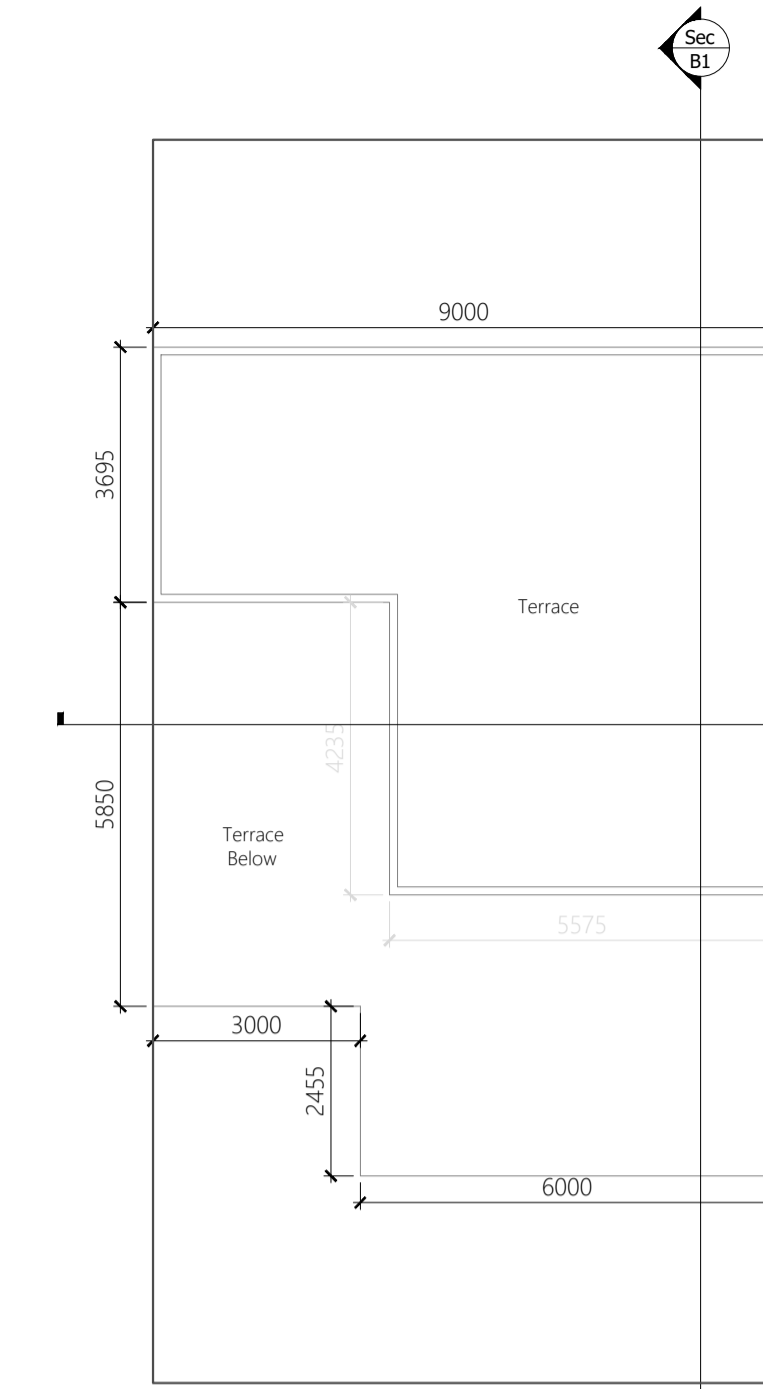

TERRACE Floor Plan
SCALE -1:100



Front Elevation
SCALE -1:100



Section-B1
SCALE -1:100

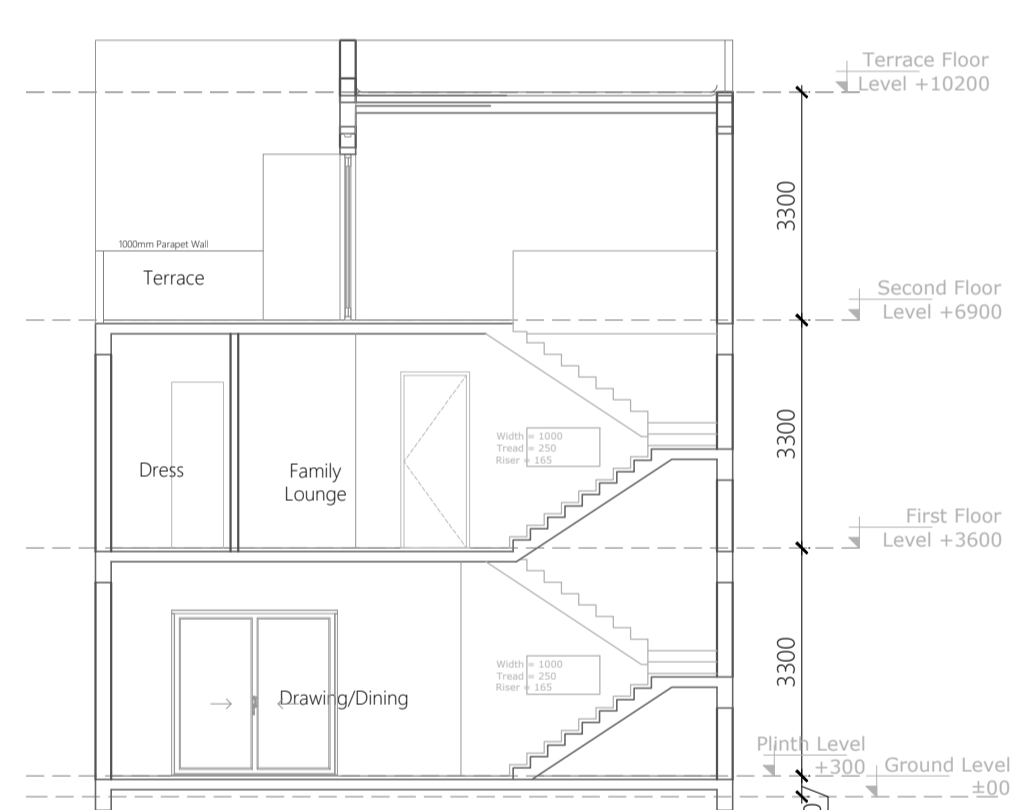

Section-A1
SCALE -1:100

Ground Floor Area Calculation				
Tag	Description	Size	Nos.	Area Sq.mtr.
1	Rectangle	2.045	3.000	6.135 Sq.mtr
2	Rectangle	9.000	10.100	90.900 Sq.mtr
3	Rectangle	3.935	1.990	7.831 Sq.mtr
Total				104.866 Sq.mtr

First Floor Area Calculation				
Tag	Description	Size	Nos.	Area Sq.mtr.
1	Rectangle	9.000	9.510	85.590 Sq.mtr
2	Rectangle	5.675	2.490	14.131 Sq.mtr
Total				99.721 Sq.mtr

Second Floor Area Calculation				
Tag	Description	Size	Nos.	Area Sq.mtr.
1	Rectangle	5.575	7.930	44.210 Sq.mtr
2	Rectangle	3.425	3.695	12.655 Sq.mtr
Total				56.865 Sq.mtr

NOTE :- ALL DIMENSIONS ARE IN MM

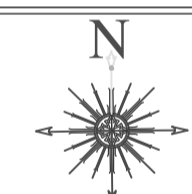

PROJECT ADDRESS:-

VILLA (9.0MX18.0M) IN
OMAXE HITECH CITY , LUCKNOW U.P.

OWNER NAME:-

OMAXE GARV BUILDTECH PVT LIMITED

This drawing is a "COPYRIGHT" contents of this drawing or part thereof may not be used or reproduced without the permission of the Architect

OWNER SIGNATURE

ARCHITECT SIGNATURE



Ar. Sachin Yadav
CA/2021/140419

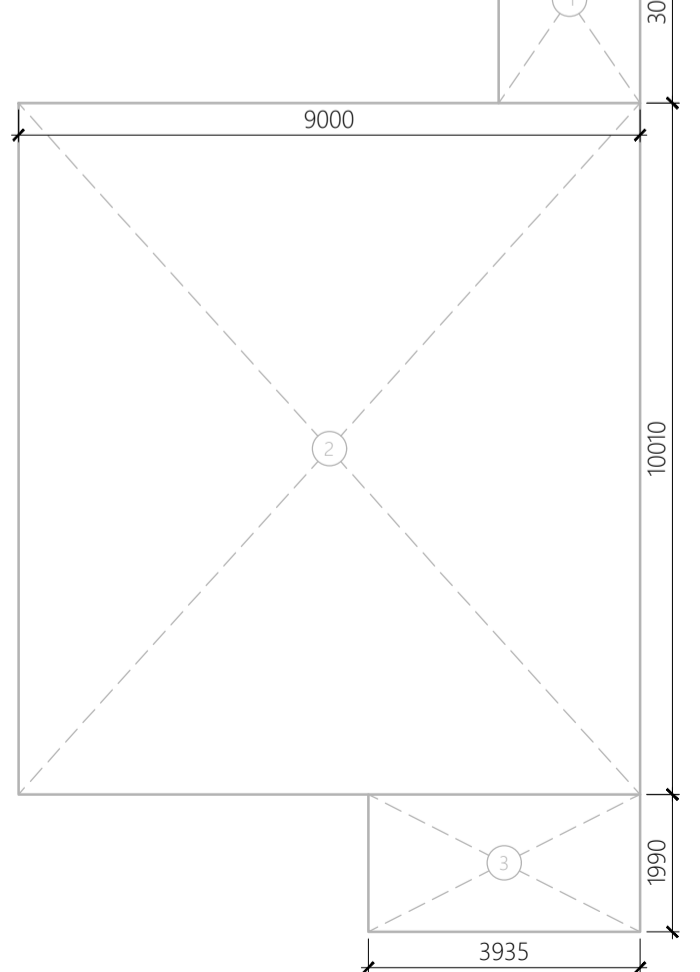

Area Envelope Plan of
Ground Floor

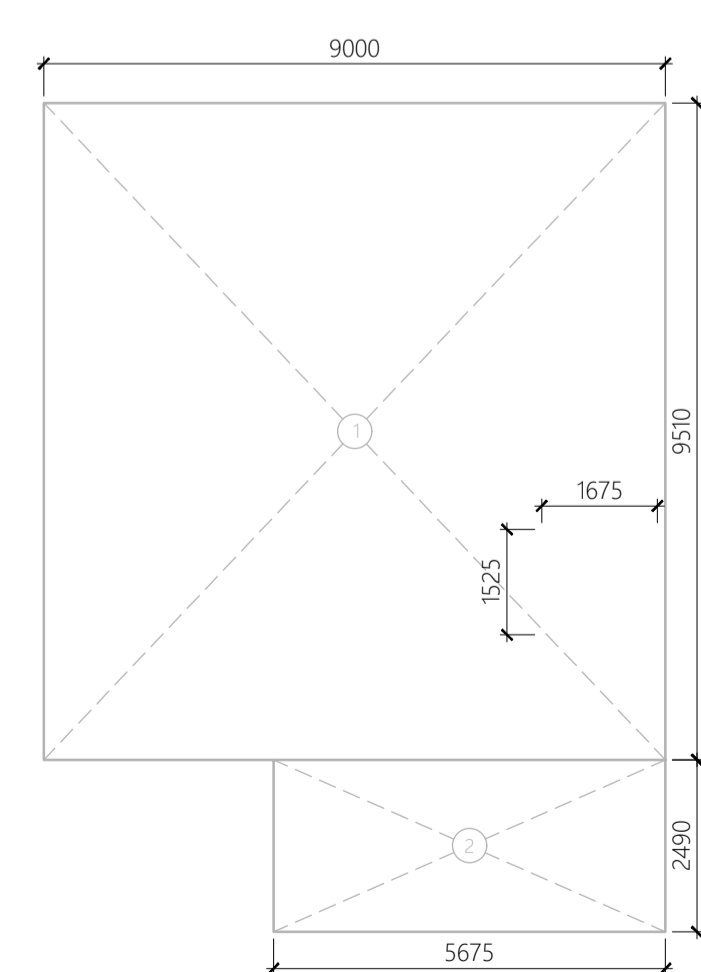

Area Envelope Plan of
First Floor

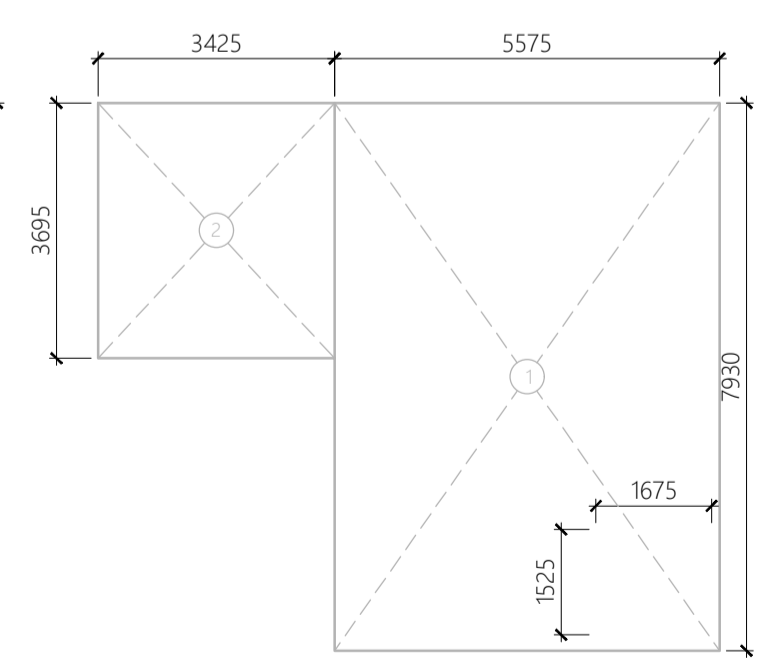

Area Envelope Plan of
Second Floor

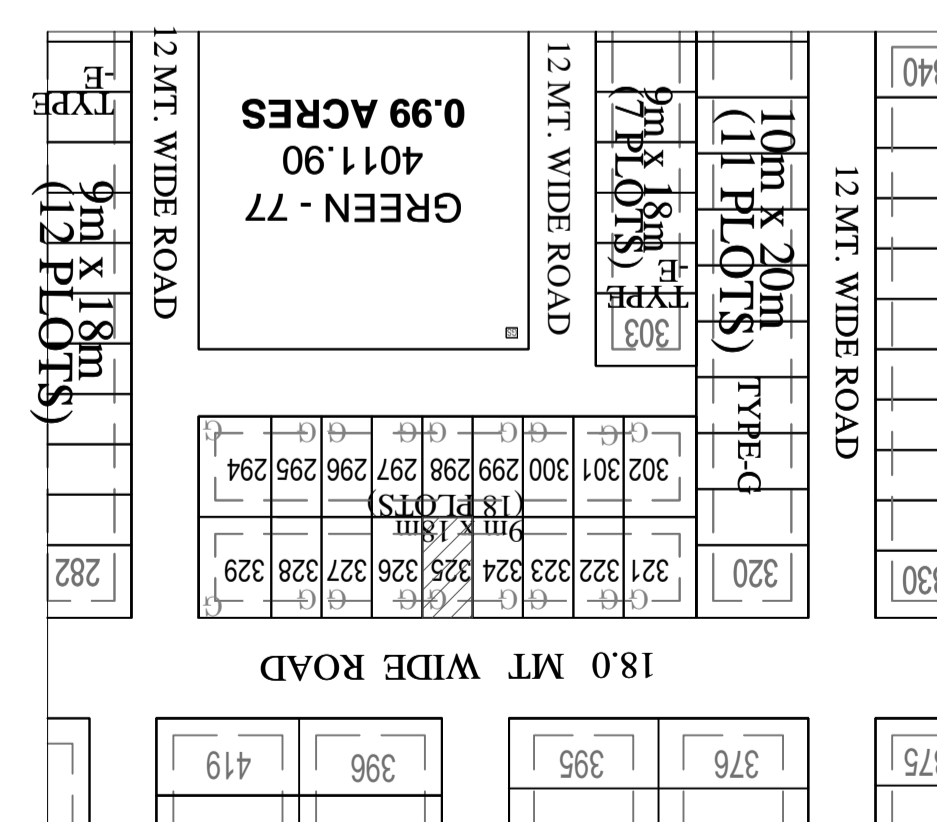

KEY PLAN
SCALE -1:100

DOOR - WINDOW SCHEDULE			
S. No.	Type	Size	Remark
1	DW1	2400x2400	Door/ Window
2	DW2	1800x2400	Door/ Window
3	DW2	1370x2400	Door/ Window
4	D1	1500x2400	Door
5	D2	1000x2400	Door
6	D3	900x2400	Door
7	D4	750x2400	Door
8	W1	1200x1500	Window
9	W2	750x1200	Window



FOR OFFICE :-

PROJECT TITLE-

**PROPOSED RESIDENTIAL
SUBMISSION DRAWING FOR THE
VILLA ON PLOT NO - 326 P1
POCKET - L TYPE- E OMAXE
HI-TECH CITY AT LUCKNOW**

AREA STATEMENT

S.NO.	PARTICULARS	SQ.MTR.
1.	PLOT AREA	162.0
2.	PERMISSIBLE GROUND FLOOR COVERAGE (65%)	105.300
3.	PROPOSED GROUND COVERAGE(64.19%)	104.00
4.	PROPOSED FIRST FLOOR AREA	97.166
5.	PROPOSED SECOND FLOOR AREA	56.865
6.	PROPOSED TERRACE FLOOR AREA	0.0
7.	PROPOSED PORCH AREA	10.08
8.	PERMISSIBLE F. A. R. (2.0)	324.00
9.	PROPOSED F. A. R. = [G.F. + F.F.+S.F.](1.592)	258.031
10.	TOTAL COVERED AREA (3+4+5+6+7)	268.11

NOTE :- ALL DIMENSIONS ARE IN MM

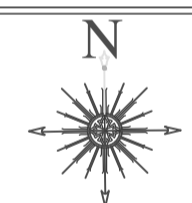

PROJECT ADDRESS:-

**VILLA (9.0MX18.0M) IN
OMAXE HITECH CITY , LUCKNOW U.P.**

OWNER NAME:-

OMAXE GARV BUILTECH PVT LIMITED

This drawing is a "COPYRIGHT" contents of this drawing or part thereof may not be used or reproduced without the permission of the Architect

OWNER SIGNATURE



ARCHITECT SIGNATURE

Sachin Yadav
Ar. Sachin Yadav
CA/2021/140419

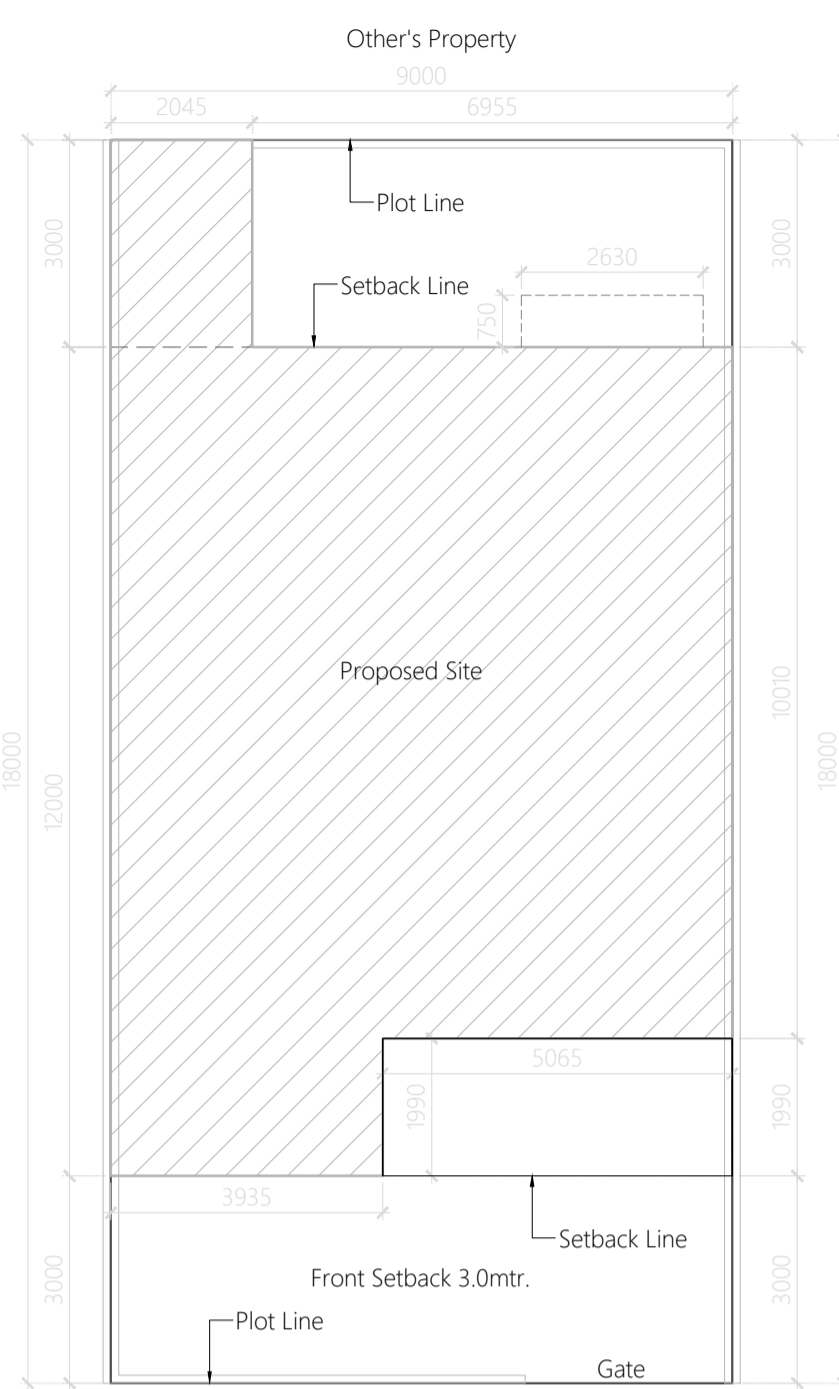

Site Plan
SCALE -1:100

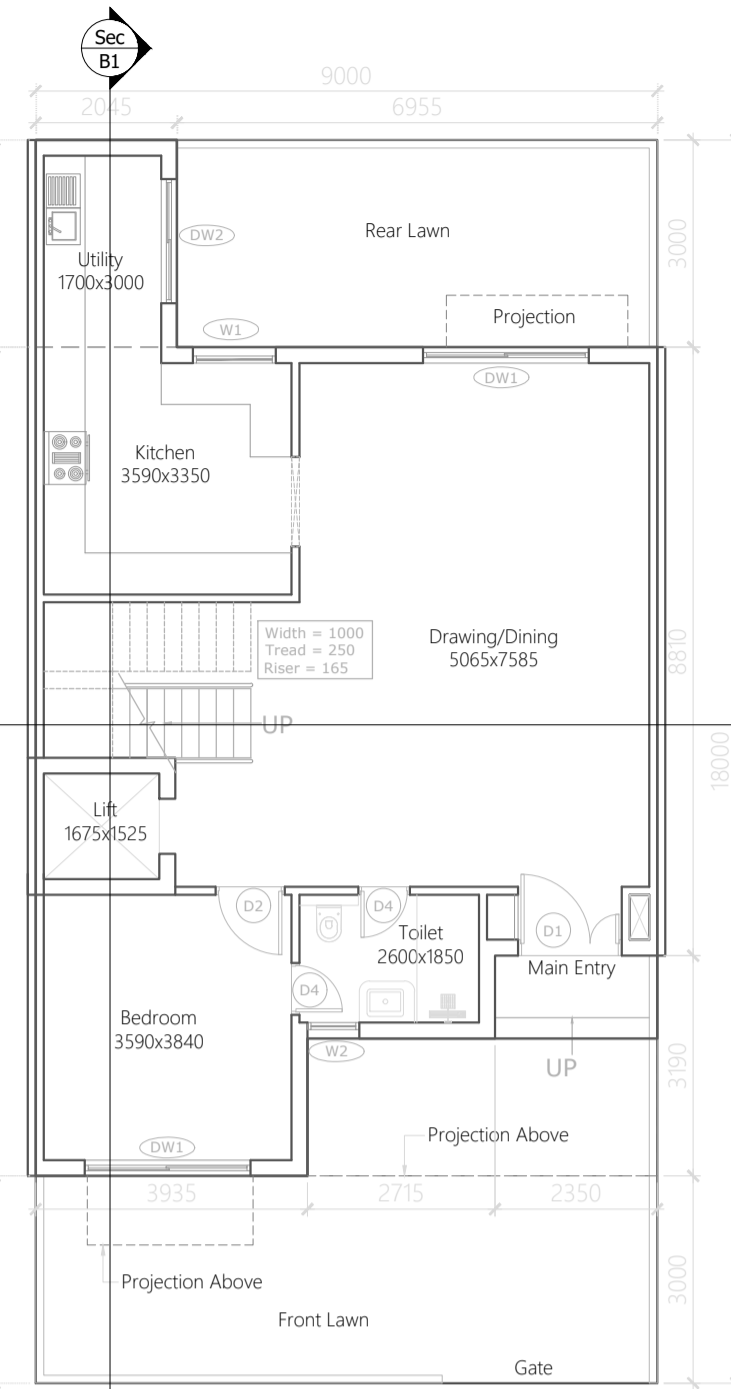

Ground Floor Plan
SCALE -1:100

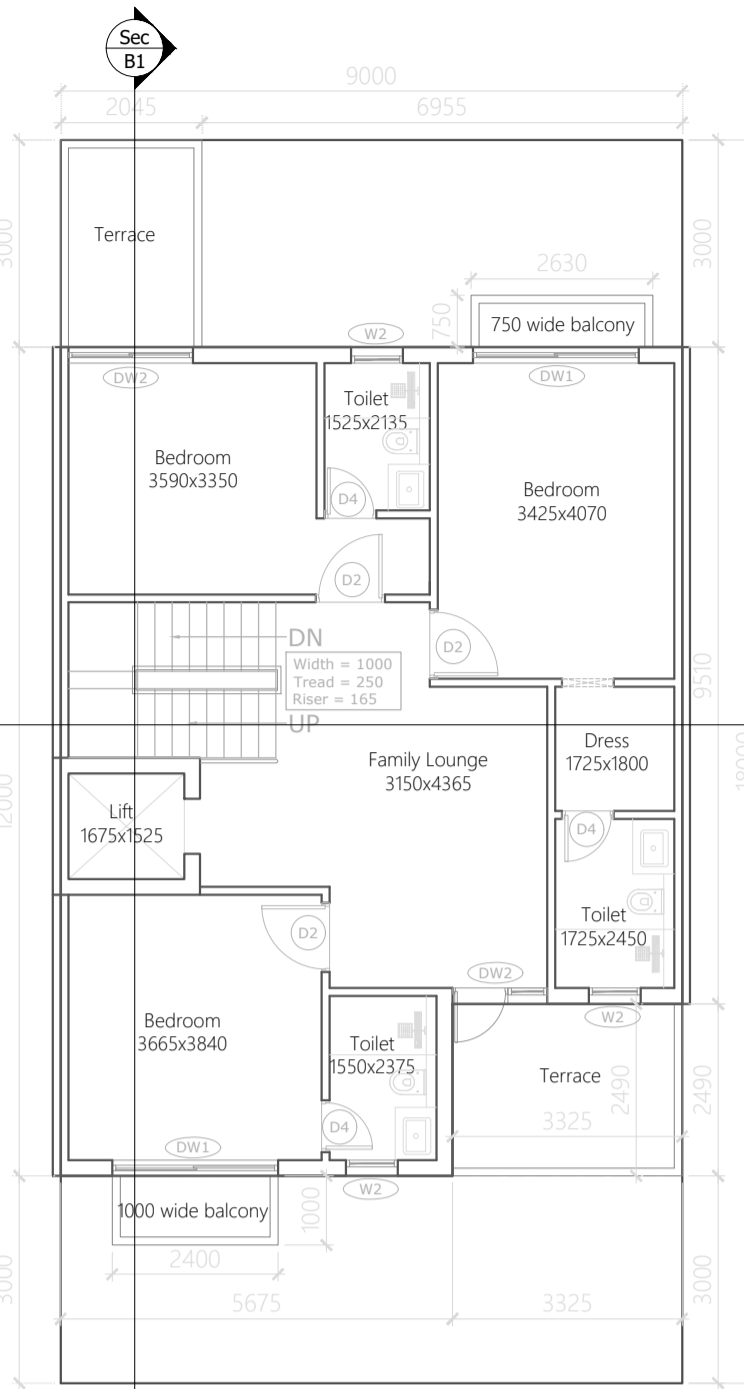

First Floor Plan
SCALE -1:100

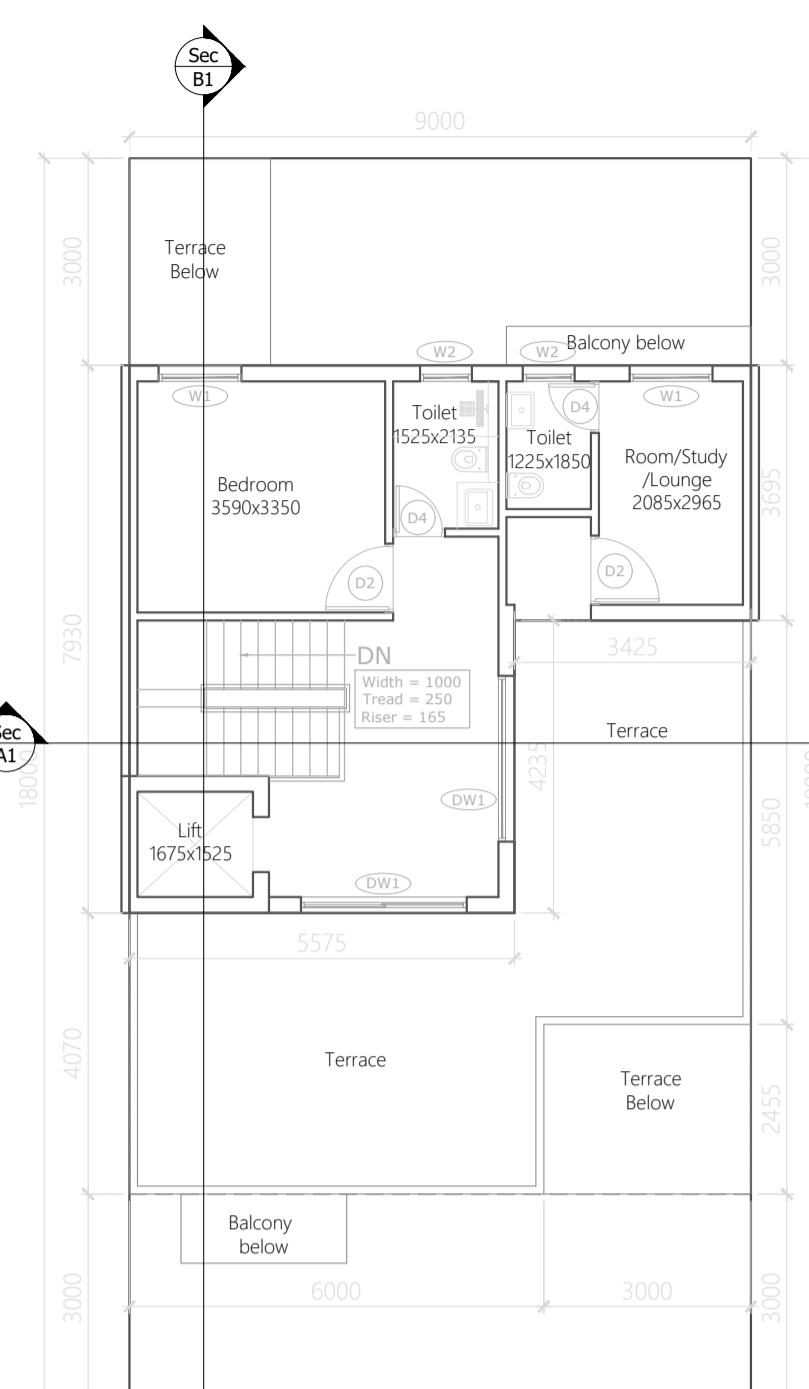

Second Floor Plan
SCALE -1:100

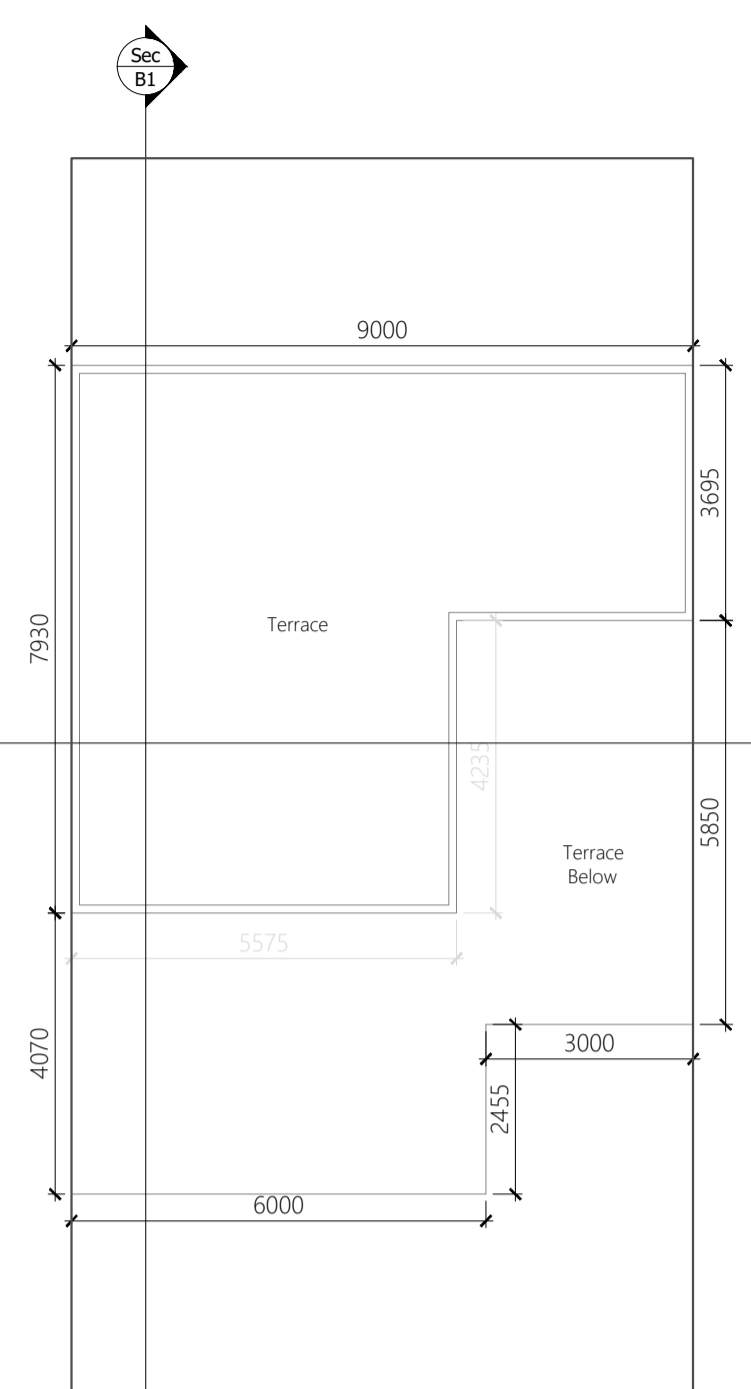

TERRACE Floor Plan
SCALE -1:100



Front Elevation
SCALE -1:100

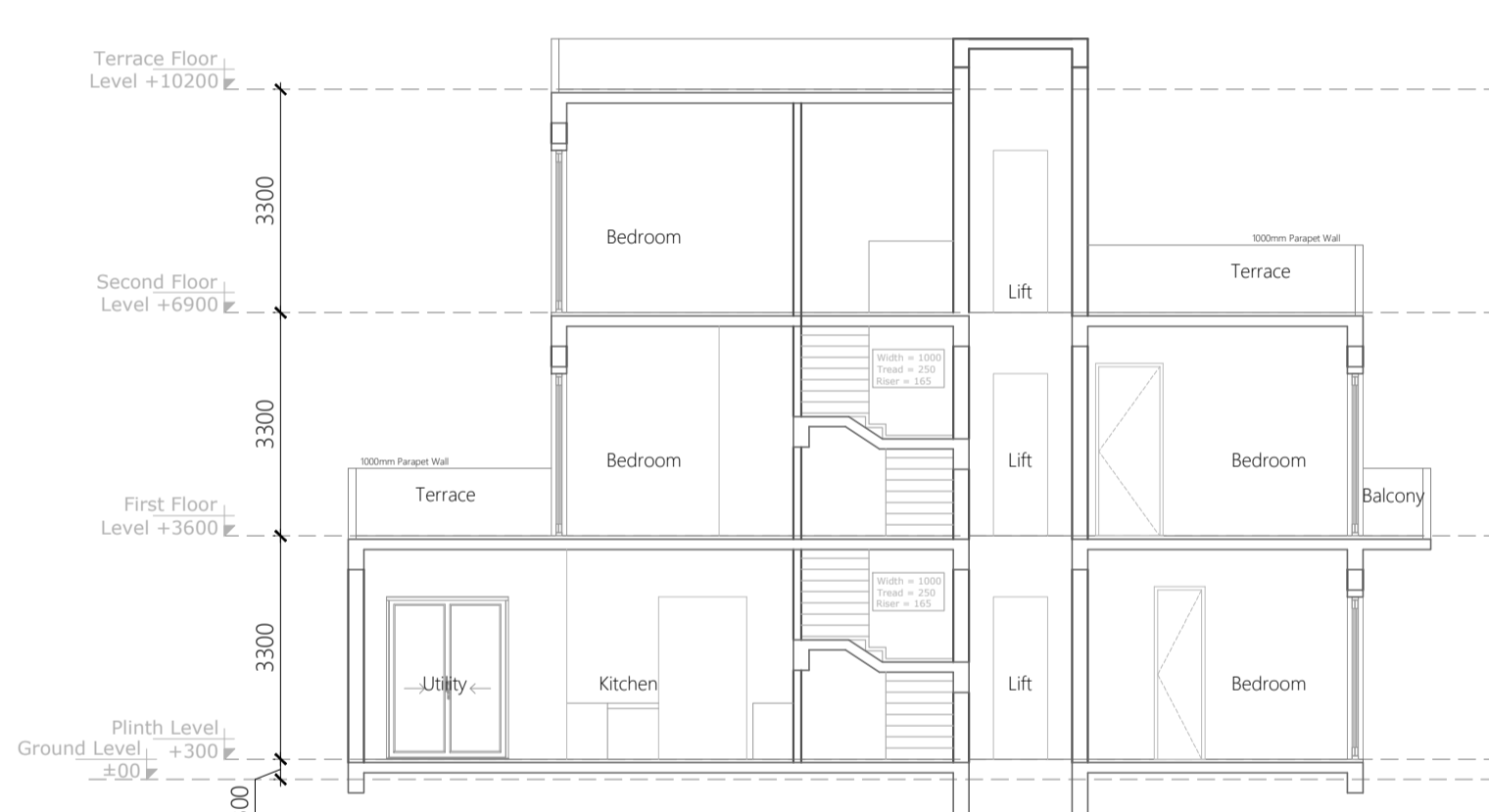

Section-B1
SCALE -1:100

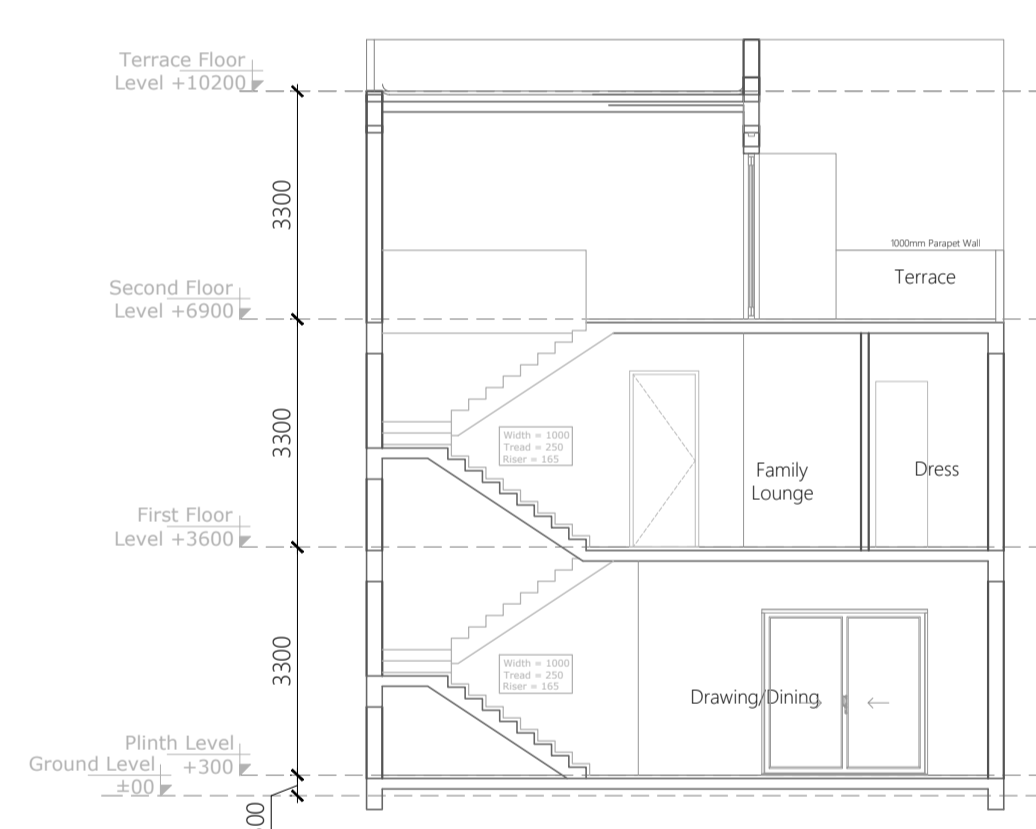

Section-A1
SCALE -1:100

Ground Floor Area Calculation

Tag	Description	Size	No.	Area Sq.mtr.	Remark
1	Rectangle	2.045 x 1.000	1	2.045	X1
2	Rectangle	3.000 x 1.000	1	3.000	X1
3	Rectangle	3.000 x 1.000	1	3.000	X1
4	Rectangle	3.000 x 1.000	1	3.000	X1
Total				12.045	

First Floor Area Calculation

Tag	Description	Size	No.	Area Sq.mtr.	Remark
1	Rectangle	3.000 x 2.400	1	7.200	X1
2	Rectangle	3.000 x 2.400	1	7.200	X1
Total				14.400	

Second Floor Area Calculation

Tag	Description	Size	No.	Area Sq.mtr.	Remark
1	Rectangle	3.000 x 1.875	1	5.625	X1
2	Rectangle	3.000 x 1.875	1	5.625	X1
Total				11.250	

Area for Deduction

Tag	Description	Size	No.	Area Sq.mtr.	Remark
1	Rectangle	3.000 x 1.000	1	3.000	X1
2	Rectangle	3.000 x 1.000	1	3.000	X1
Total				6.000	

Area for Deduction

Tag	Description	Size	No.	Area Sq.mtr.	Remark
1	Rectangle	3.000 x 1.000	1	3.000	X1
2	Rectangle	3.000 x 1.000	1	3.000	X1
Total				6.000	

Area for Deduction

Tag	Description	Size	No.	Area Sq.mtr.	Remark
1	Rectangle	3.000 x 1.000	1	3.000	X1
2	Rectangle	3.000 x 1.000	1	3.000	X1
Total				6.000	

DOOR - WINDOW SCHEDULE

S. No.	Type	Size	Remark
1	DW1	2400x2400	Door/ Window
2	DW2	1800x2400	Door/ Window
3	DW2	1370x2400	Door/ Window
4	D1	1500x2400	Door
5	D2	1000x2400	Door
6	D3	900x2400	Door
7	D4	750x2400	Door
8	W1	1200x1500	Window
9	W2	750x1200	Window

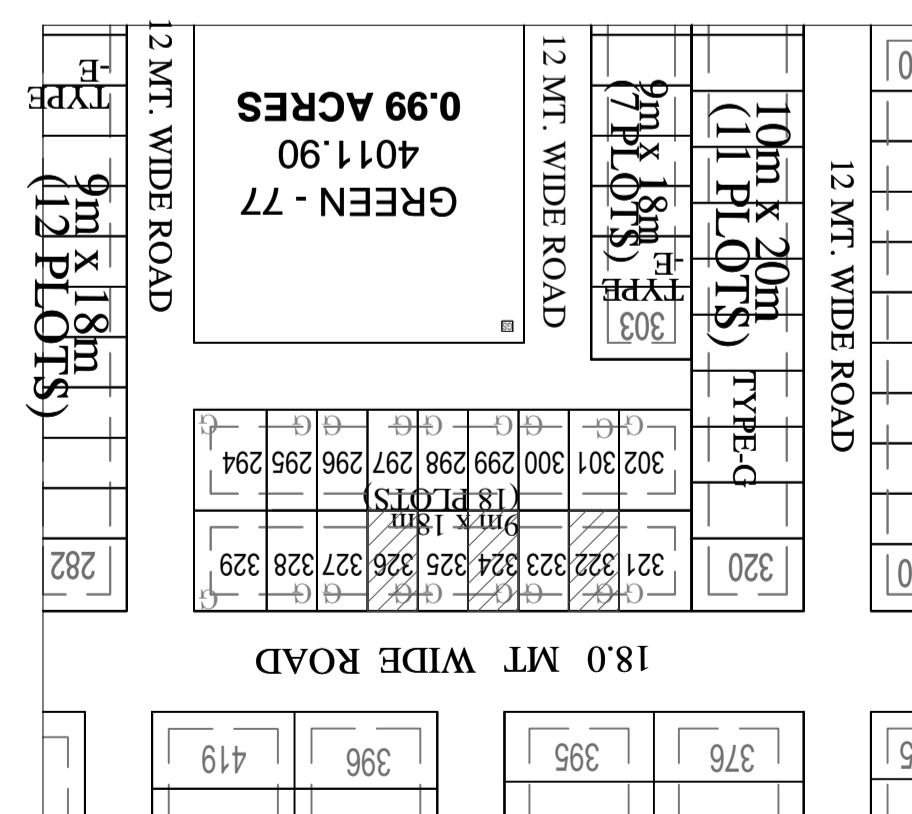

KEY PLAN
SCALE -1:100

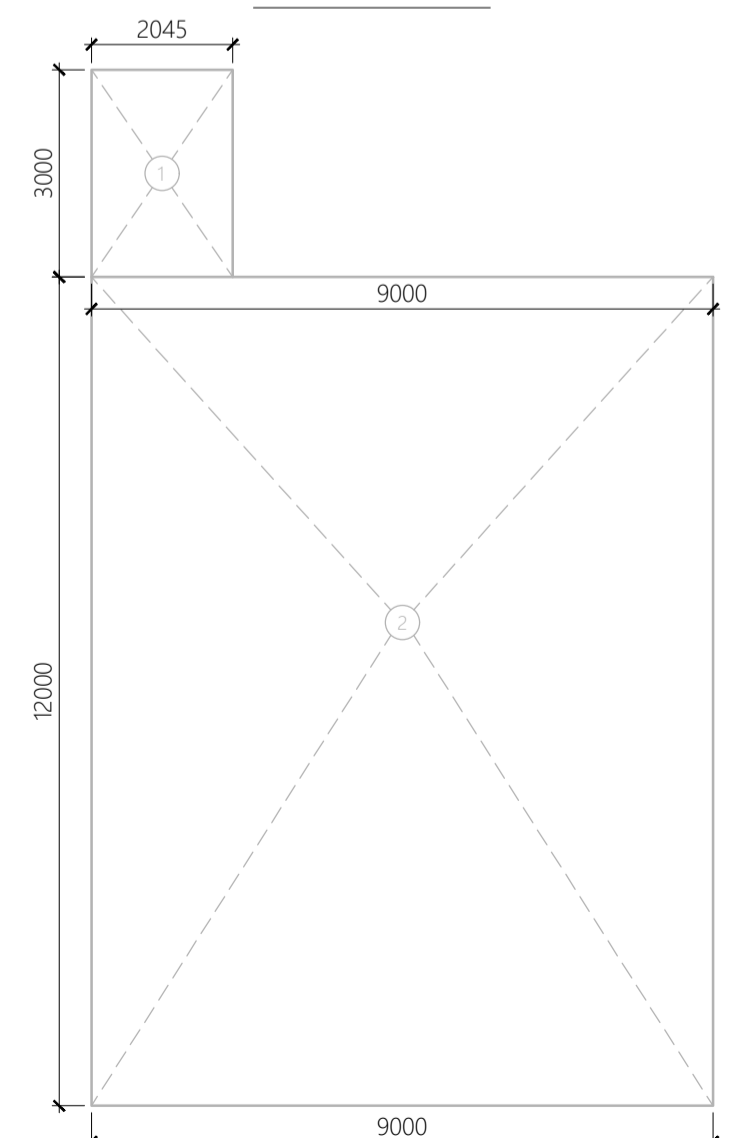

Area Envelope Plan of
Ground Floor

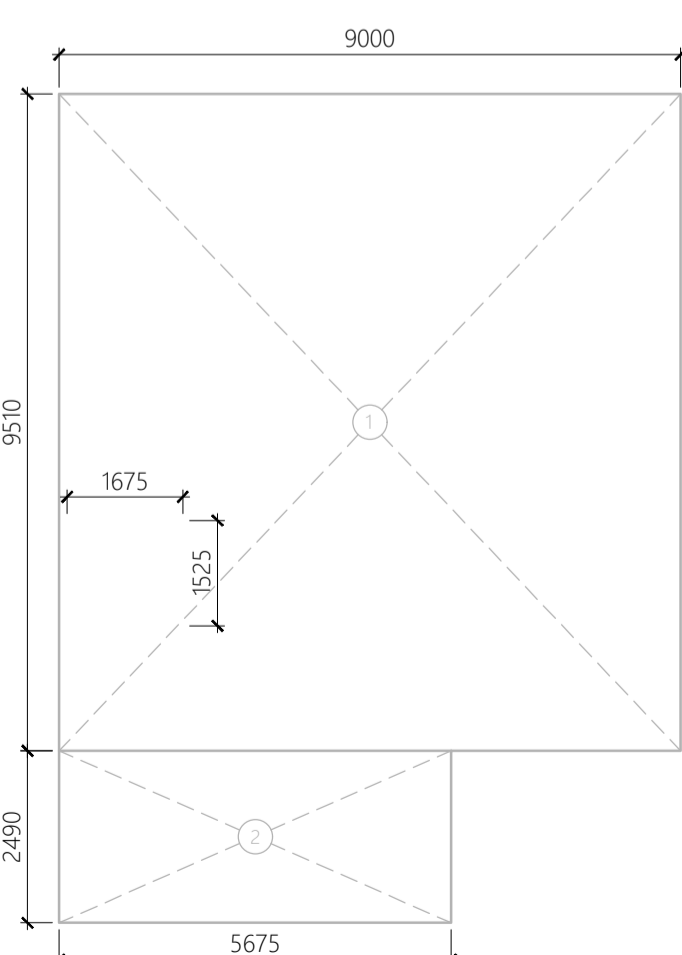

Area Envelope Plan of
First Floor

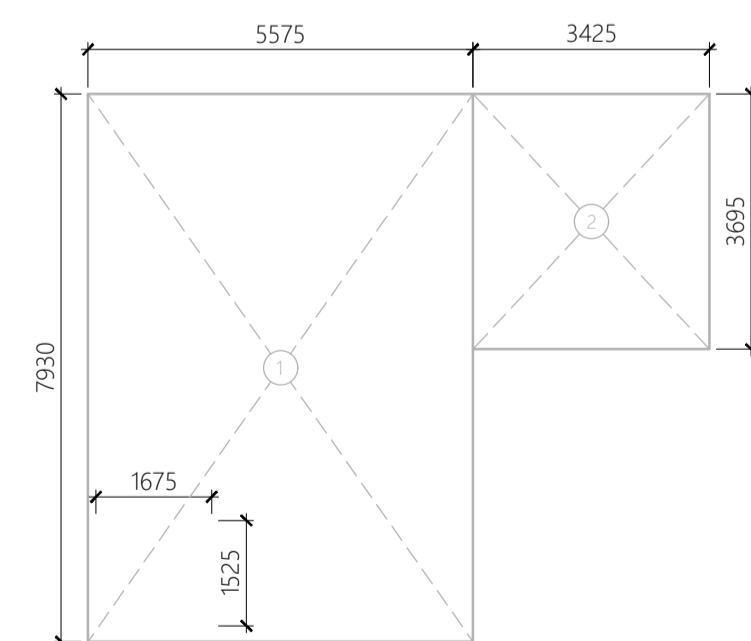

Area Envelope Plan of
Second Floor



Lucknow Development Authority

FOR OFFICE :-

PROJECT TITLE-

PROPOSED RESIDENTIAL
SUBMISSION DRAWING FOR THE
VILLA ON PLOT NO - 327 P1
POCKET - L TYPE- E OMAXE HI-TECH
CITY AT LUCKNOW

AREA STATEMENT

S.NO.	PARTICULARS	SQ.MTR.
1.	PLOT AREA	162.0
2.	PERMISSIBLE GROUND FLOOR COVERAGE (65%)	105.300
3.	PROPOSED GROUND COVERAGE(64.19%)	104.00
4.	PROPOSED FIRST FLOOR AREA	97.166
5.	PROPOSED SECOND FLOOR AREA	56.865
6.	PROPOSED TERRACE FLOOR AREA	0.0
7.	PROPOSED PORCH AREA	10.08
8.	PERMISSIBLE F. A. R. (2.0)	324.00
9.	PROPOSED F. A. R. = [G.F. + F.F.+S.F](1.592)	258.031
10.	TOTAL COVERED AREA (3+4+5+6+7)	268.11

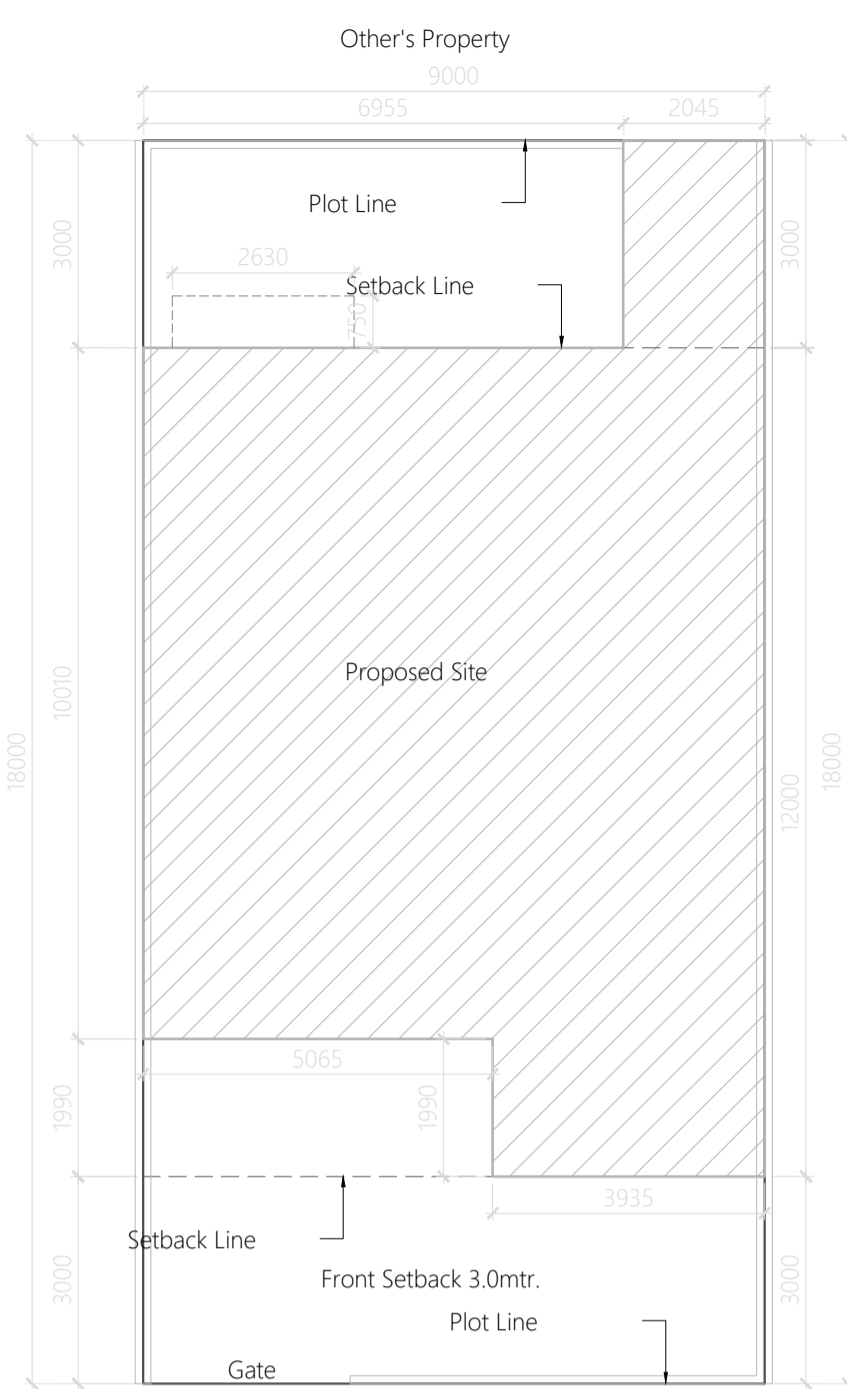

Site Plan
SCALE -1:100

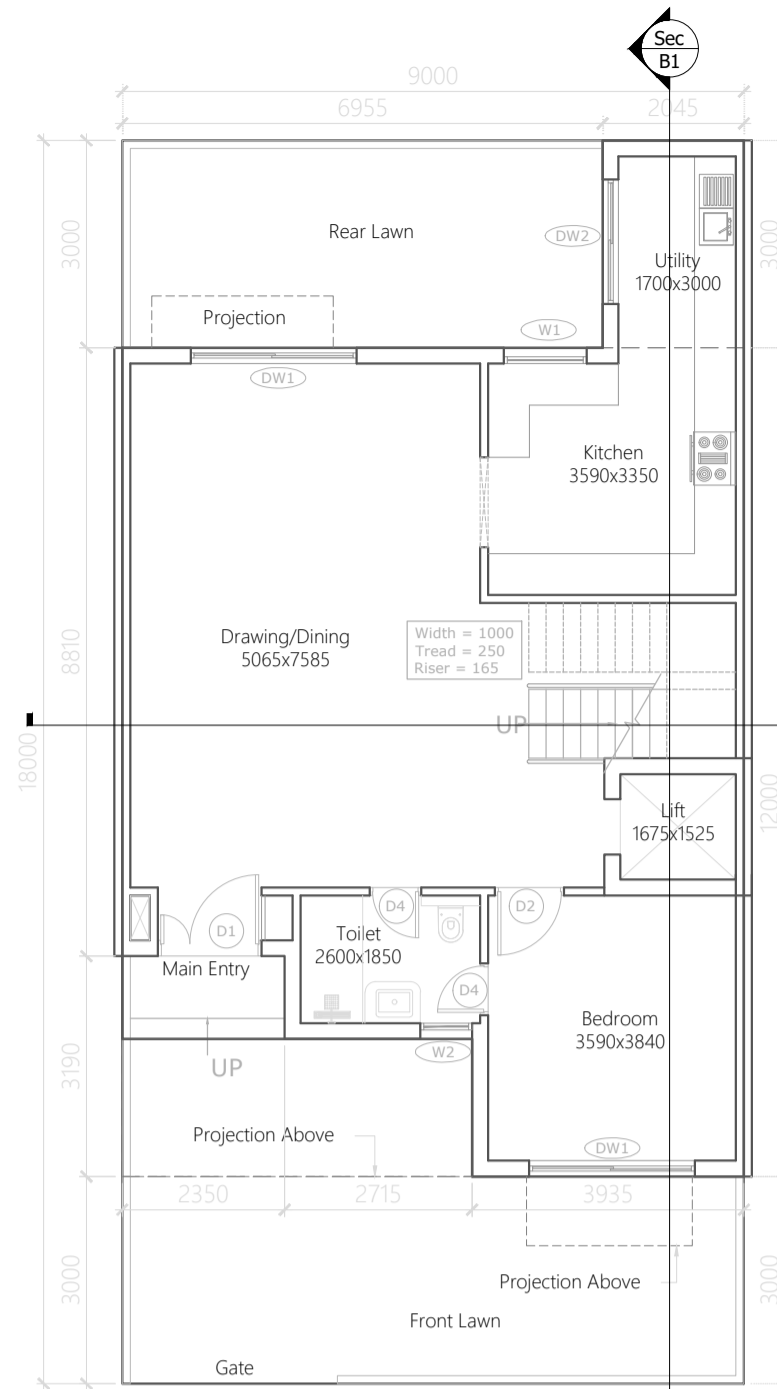

Ground Floor Plan
SCALE -1:100

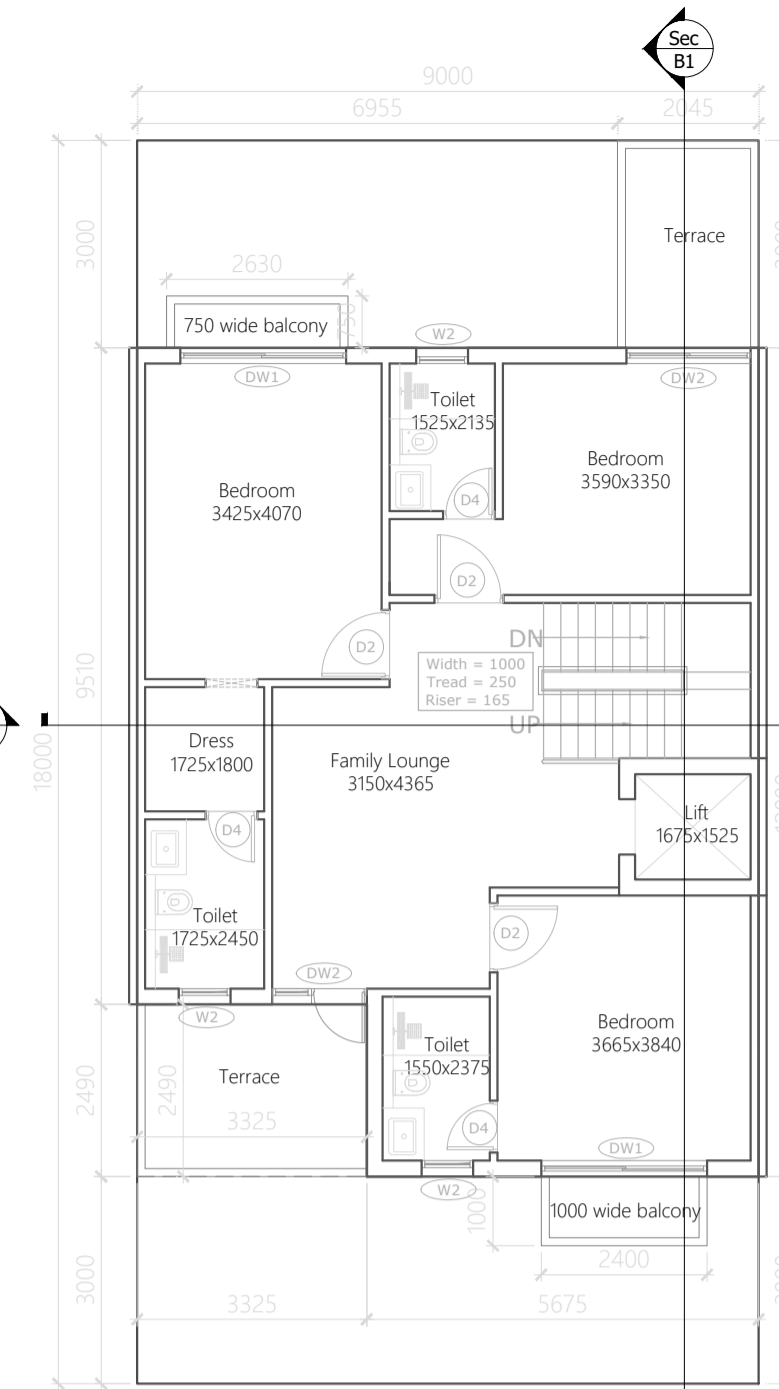

First Floor Plan
SCALE -1:100

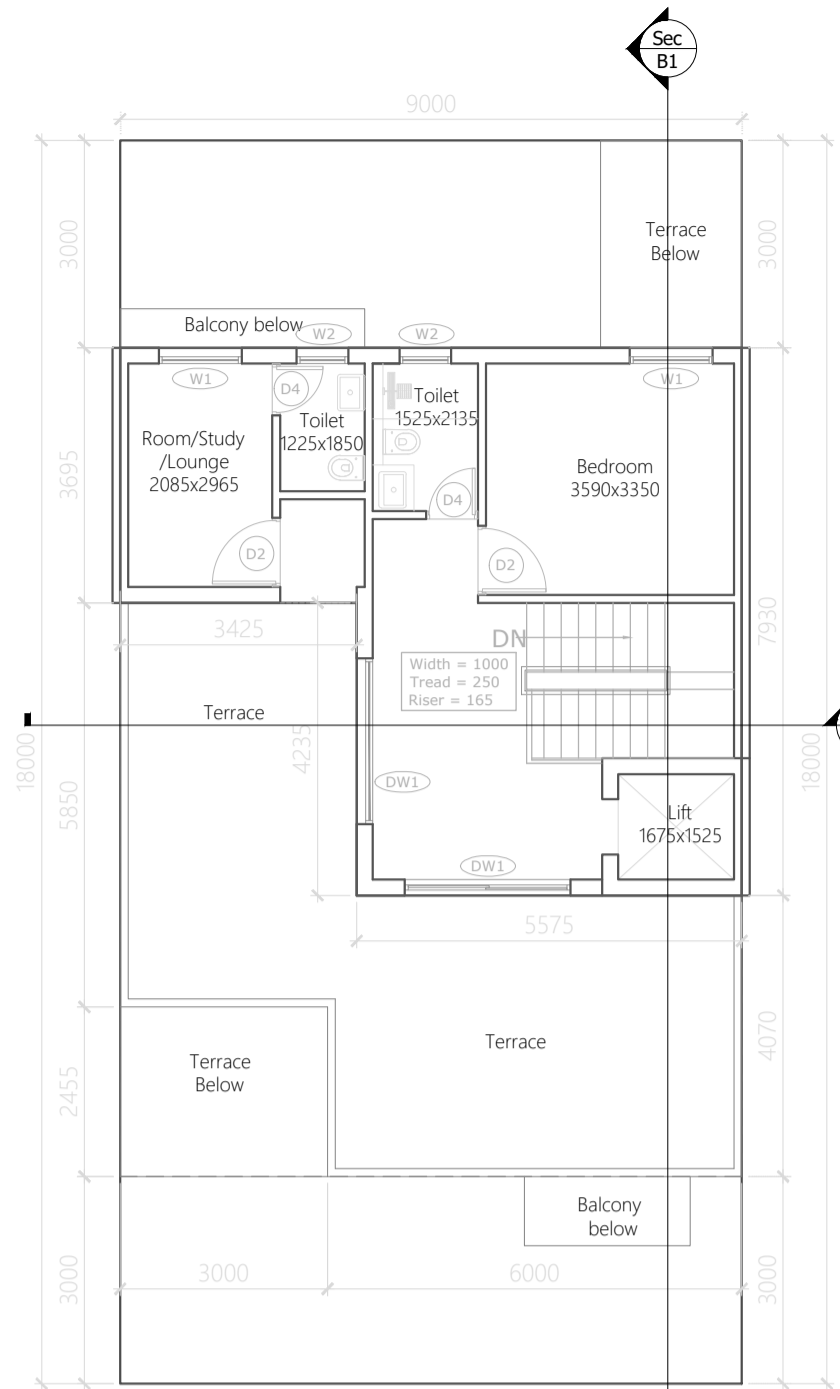

Second Floor Plan
SCALE -1:100

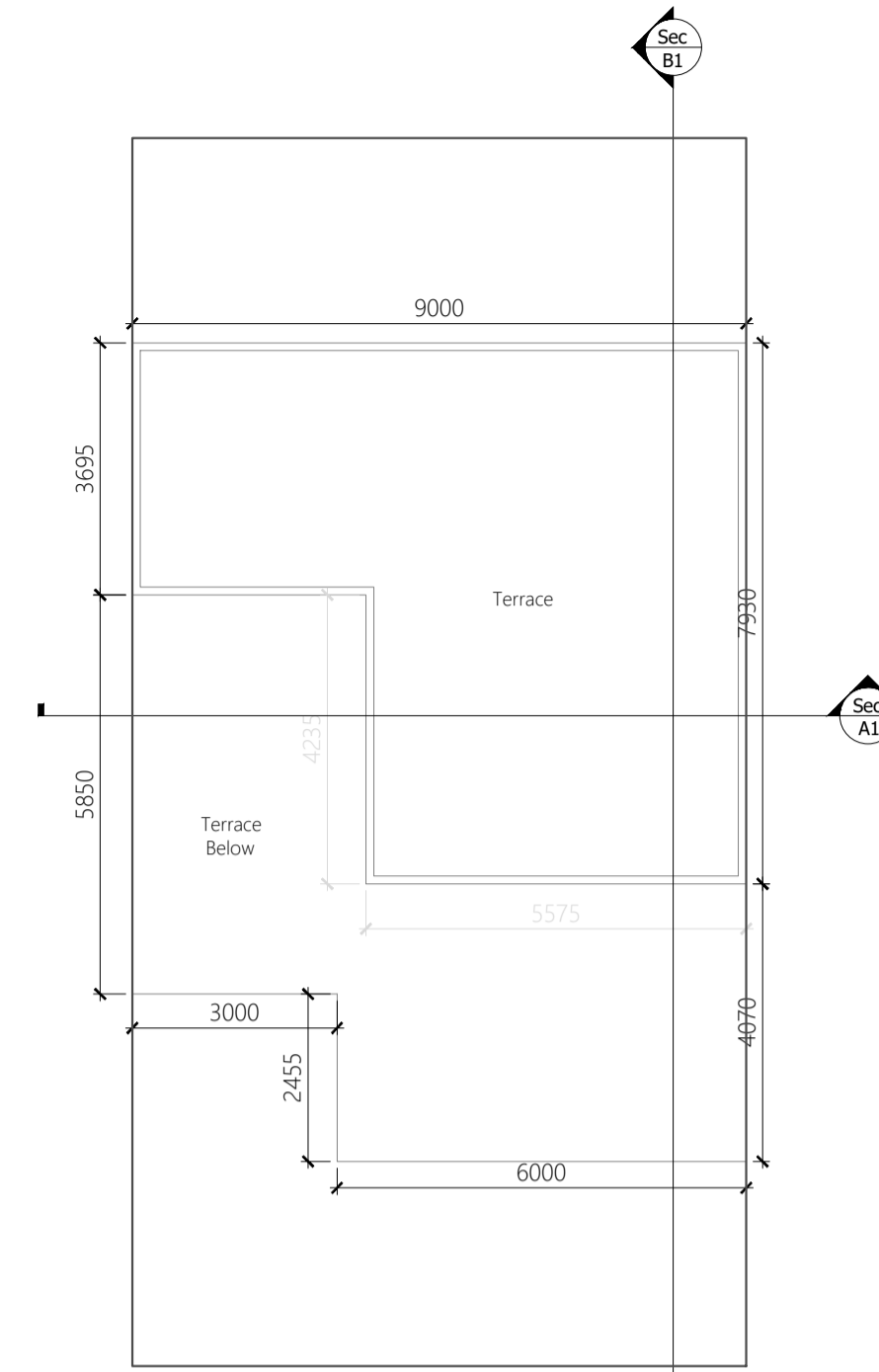

TERRACE Floor Plan
SCALE -1:100



Front Elevation
SCALE -1:100



Section-B1
SCALE -1:100

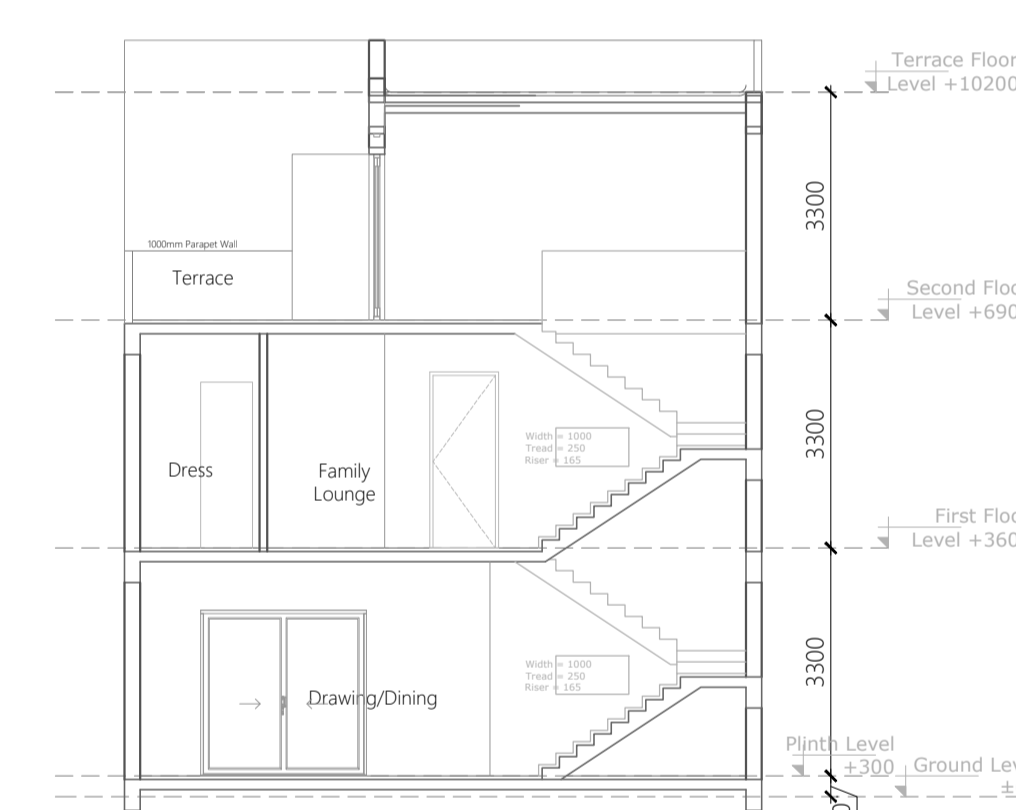

Section-A1
SCALE -1:100

Tag	Description	Size	Nos.	Area Sq.mtr.	Remark
1	Rectangle	2.045	3.000	6.135	Sq.mtr
2	Rectangle	9.000	10.100	90.900	Sq.mtr
3	Rectangle	3.935	1.990	7.831	Sq.mtr
Total				104.866	Sq.mtr

Total FAR Area at Ground Floor (X1) 104.866 Sq.mtr X2
Ground Coverage 104.866 Sq.mtr
Total Built-up Area at Ground Floor (X2) 104.866 Sq.mtr

Tag	Description	Size	Nos.	Area Sq.mtr.	Remark
1	Rectangle	9.000	9.510	85.590	Sq.mtr
2	Rectangle	5.675	2.490	14.131	Sq.mtr
Total				99.721	Sq.mtr

Total FAR Area at First Floor (X1-X2) 97.166 Sq.mtr X3
Non FAR Area 0.000 Sq.mtr
Total Built-up Area at First Floor (X3) 97.166 Sq.mtr

Tag	Description	Size	Nos.	Area Sq.mtr.	Remark
1	Rectangle	5.575	7.930	44.210	Sq.mtr
2	Rectangle	3.425	3.695	12.655	Sq.mtr
Total				56.865	Sq.mtr

Total FAR Area at Second Floor (X1-X2) 54.311 Sq.mtr X3
Non FAR Area 0.000 Sq.mtr
Total Built-up Area at Second Floor (X3) 54.311 Sq.mtr

NOTE :- ALL DIMENSIONS ARE IN MM

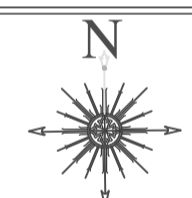

PROJECT ADDRESS:-

VILLA (9.0MX18.0M) IN
OMAXE HITECH CITY , LUCKNOW U.P.

OWNER NAME:-

OMAXE GARV BUILDTECH PVT LIMITED

This drawing is a "COPYRIGHT" contents of this drawing or part thereof may not be used or reproduced without the permission of the Architect

OWNER SIGNATURE



ARCHITECT SIGNATURE

Ar. Sachin Yadav
CA/2021/140419

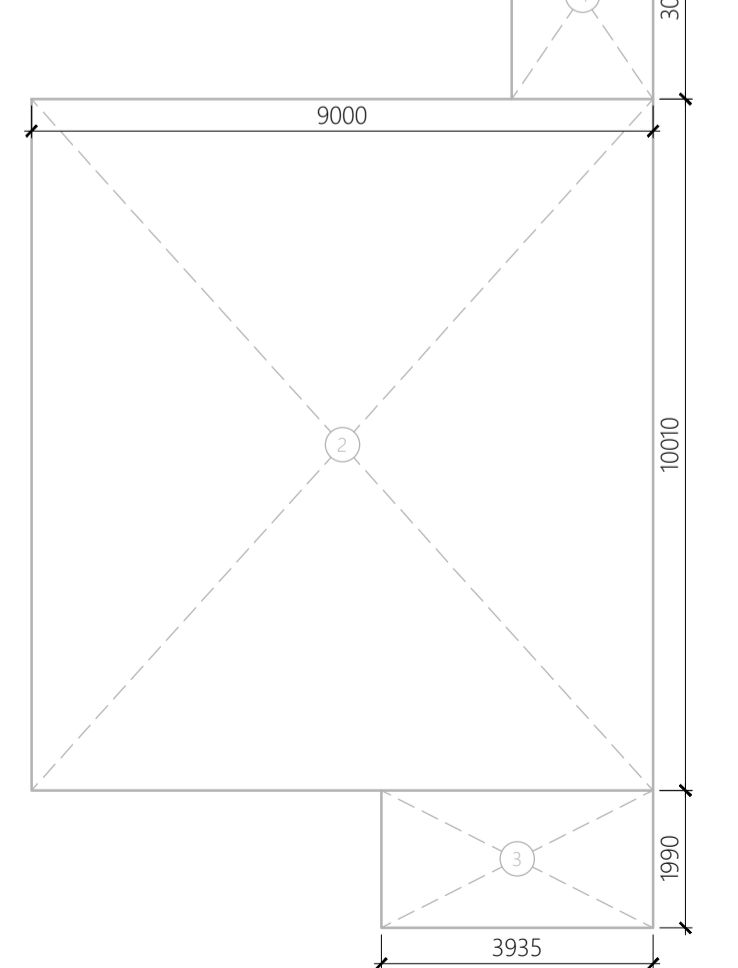

Area Envelope Plan of
Ground Floor

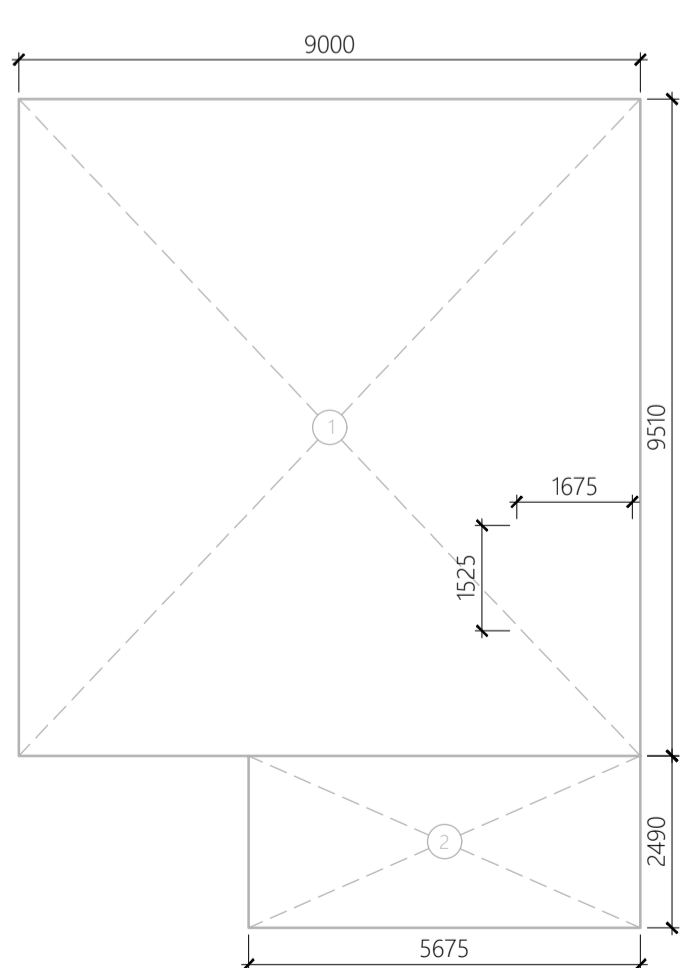

Area Envelope Plan of
First Floor

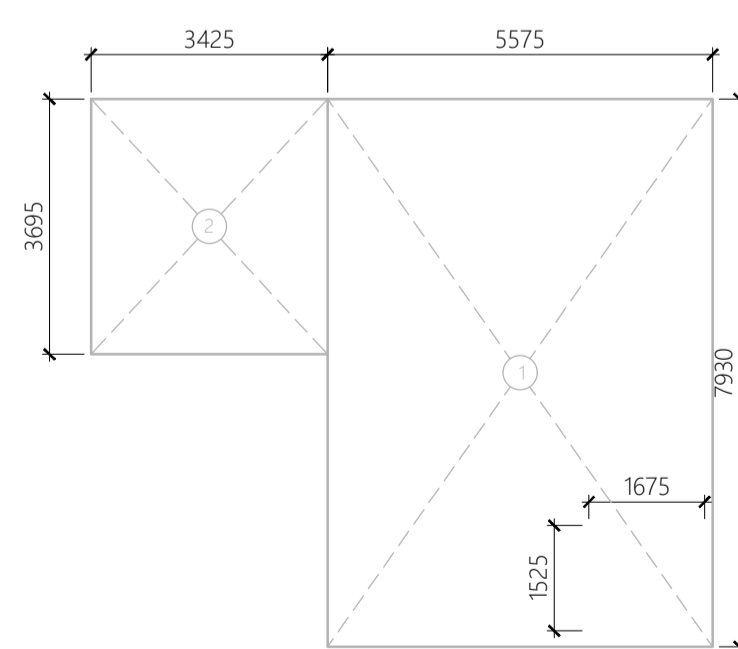

Area Envelope Plan of
Second Floor

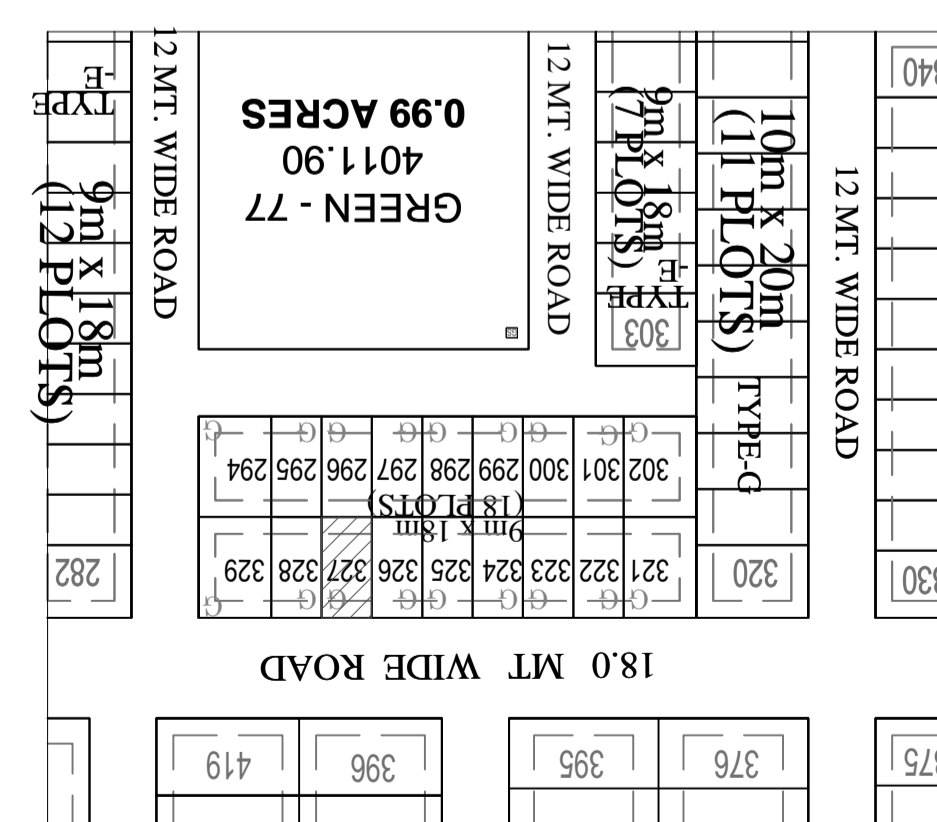

KEY PLAN
SCALE -1:100

S. No.	Type	Size	Remark
1	DW1	2400x2400	Door/ Window
2	DW2	1800x2400	Door/ Window
3	DW2	1370x2400	Door/ Window
4	D1	1500x2400	Door
5	D2	1000x2400	Door
6	D3	900x2400	Door
7	D4	750x2400	Door
8	W1	1200x1500	Window
9	W2	750x1200	Window



FOR OFFICE :-

PROJECT TITLE-

**PROPOSED RESIDENTIAL
SUBMISSION DRAWING FOR THE
VILLA ON PLOT NO - 328 P1
POCKET - L TYPE- E OMAXE
HI-TECH CITY AT LUCKNOW**

AREA STATEMENT

S.NO.	PARTICULARS	SQ.MTR.
1.	PLOT AREA	162.0
2.	PERMISSIBLE GROUND FLOOR COVERAGE (65%)	105.300
3.	PROPOSED GROUND COVERAGE(64.19%)	104.00
4.	PROPOSED FIRST FLOOR AREA	97.166
5.	PROPOSED SECOND FLOOR AREA	56.865
6.	PROPOSED TERRACE FLOOR AREA	0.0
7.	PROPOSED PORCH AREA	10.08
8.	PERMISSIBLE F. A. R. (2.0)	324.00
9.	PROPOSED F. A. R. = [G.F. + F.F.+S.F.](1.592)	258.031
10.	TOTAL COVERED AREA (3+4+5+6+7)	268.11

NOTE :- ALL DIMENSIONS ARE IN MM

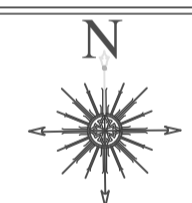

PROJECT ADDRESS:-

**VILLA (9.0MX18.0M) IN
OMAXE HITECH CITY , LUCKNOW U.P.**

OWNER NAME:-

OMAXE GARV BUILDTECH PVT LIMITED

This drawing is a "COPYRIGHT" contents of this drawing or part thereof may not be used or reproduced without the permission of the Architect

OWNER SIGNATURE



ARCHITECT SIGNATURE

Sachin Yadav
Ar. Sachin Yadav
CA/2021/140419

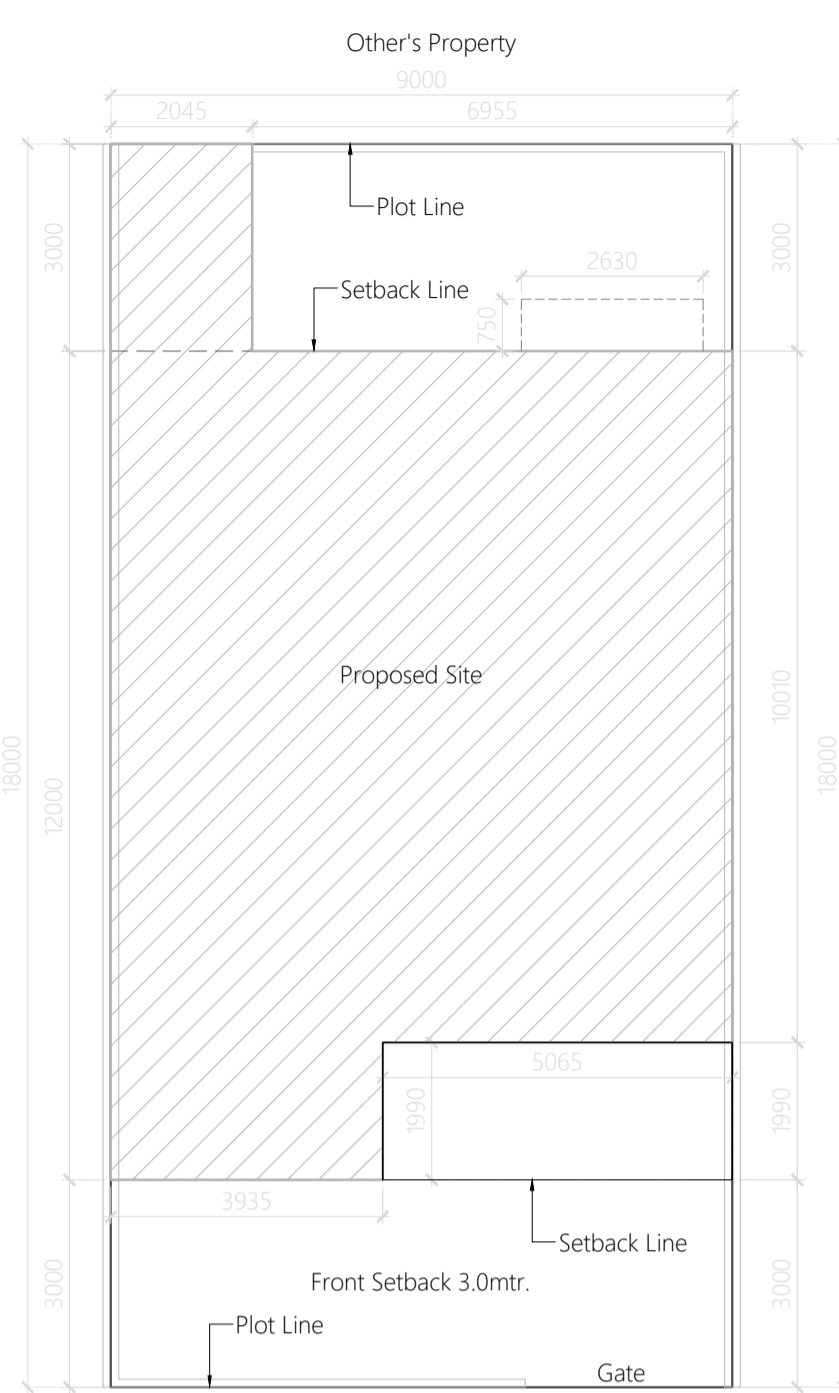

Site Plan
SCALE -1:100

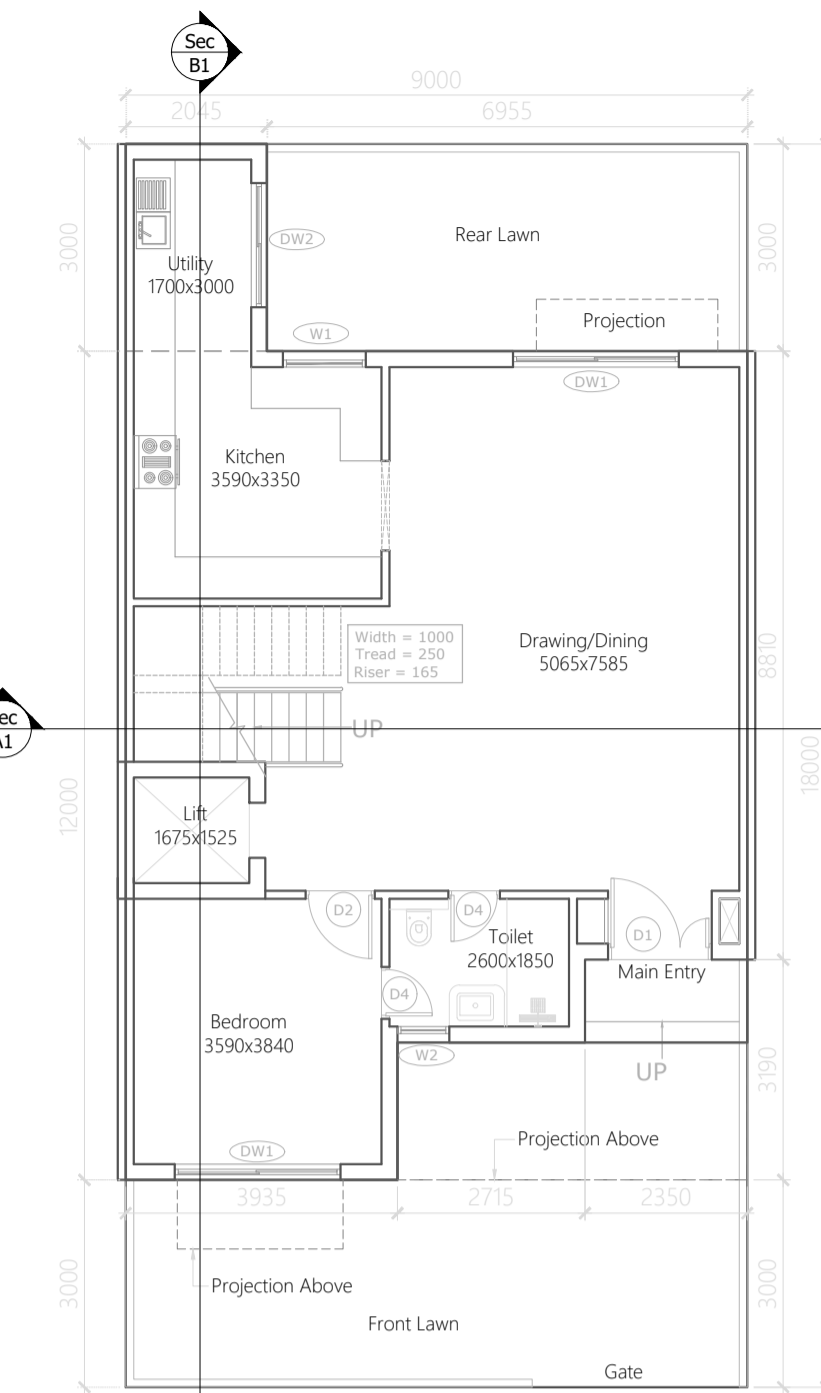

Ground Floor Plan
SCALE -1:100

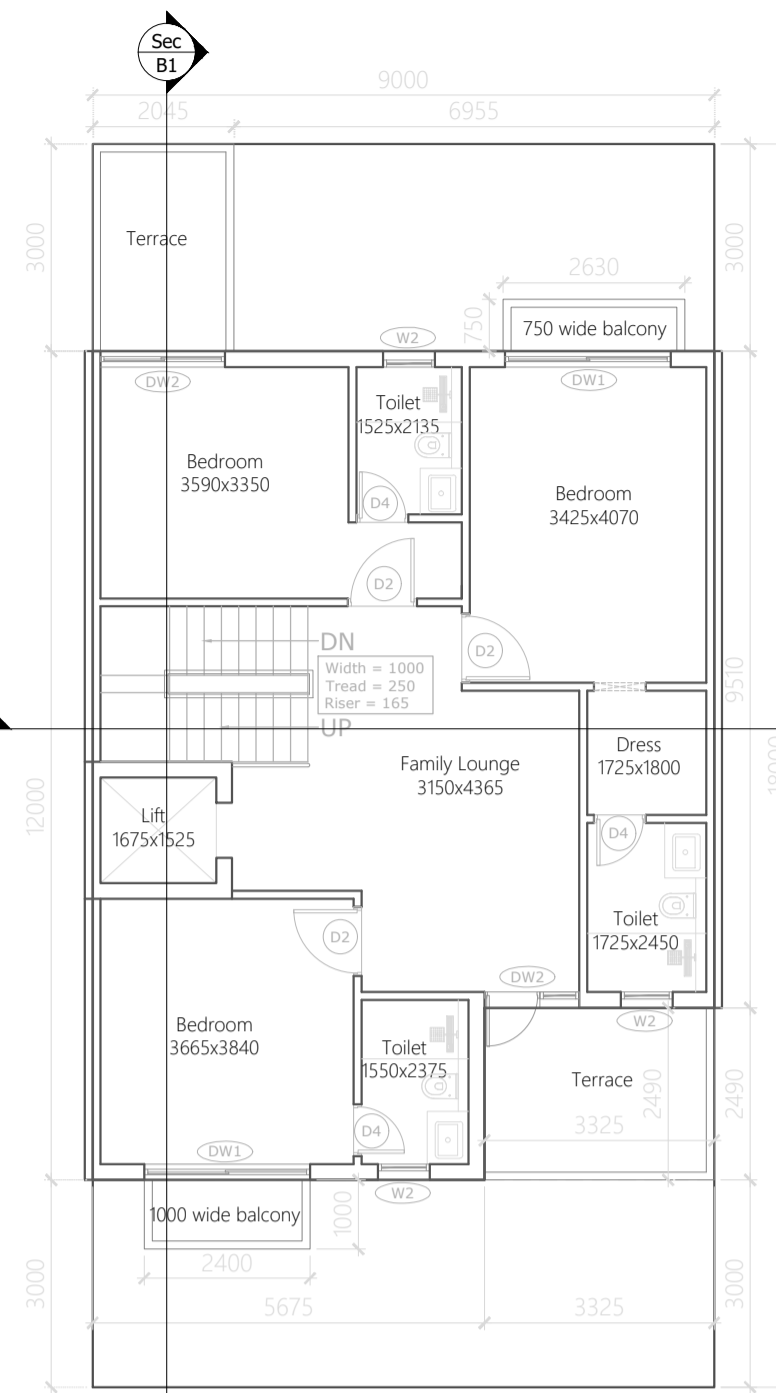

First Floor Plan
SCALE -1:100

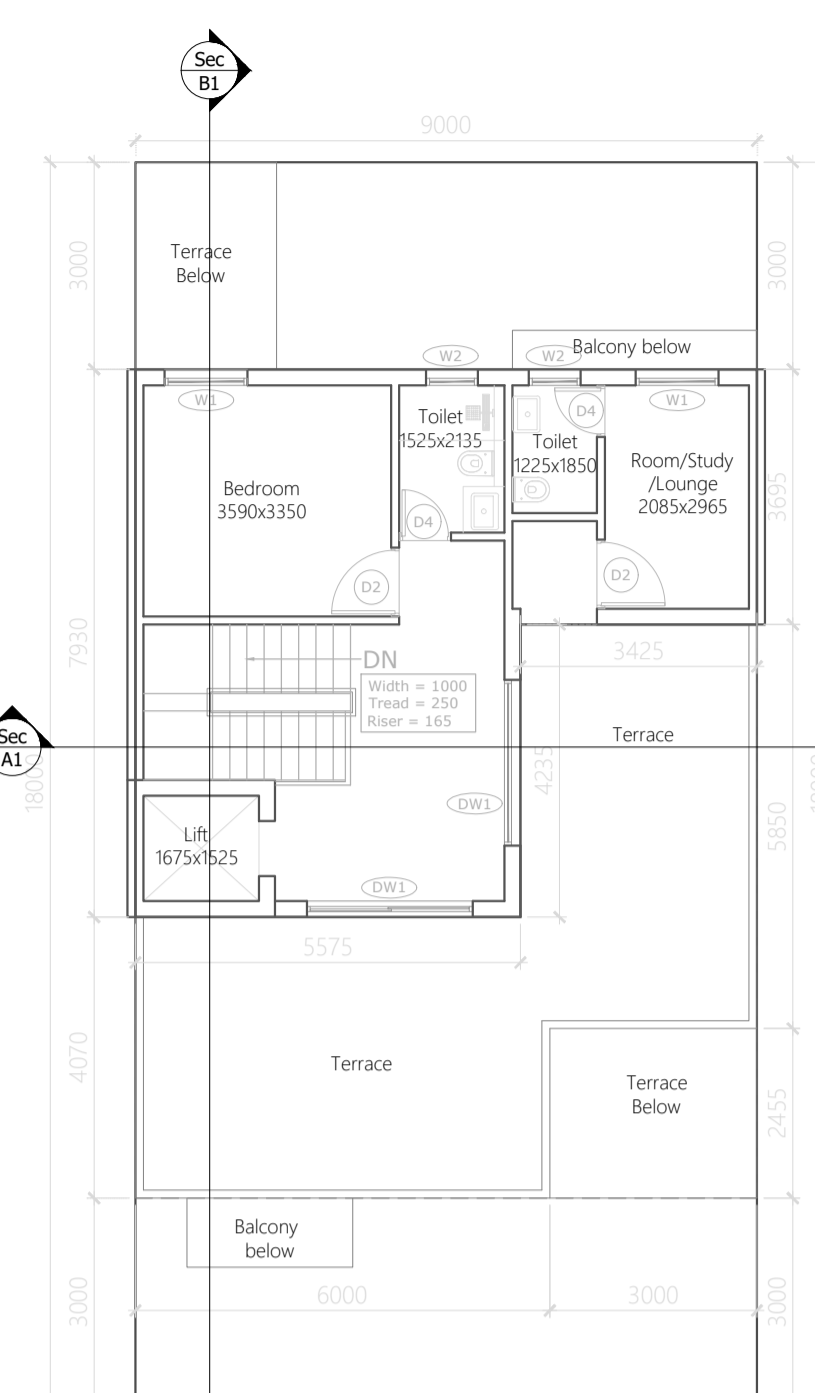

Second Floor Plan
SCALE -1:100

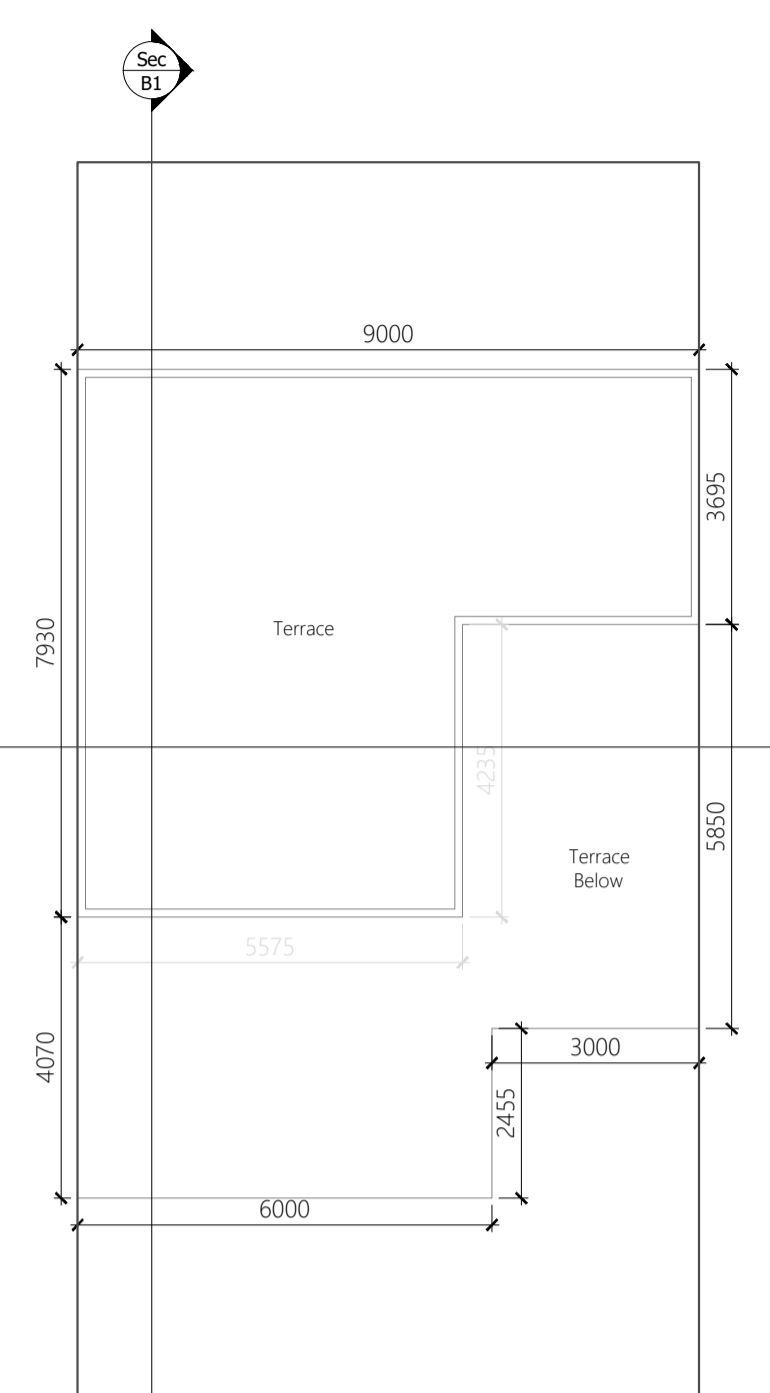

TERRACE Floor Plan
SCALE -1:100



Front Elevation
SCALE -1:100



Section-B1
SCALE -1:100

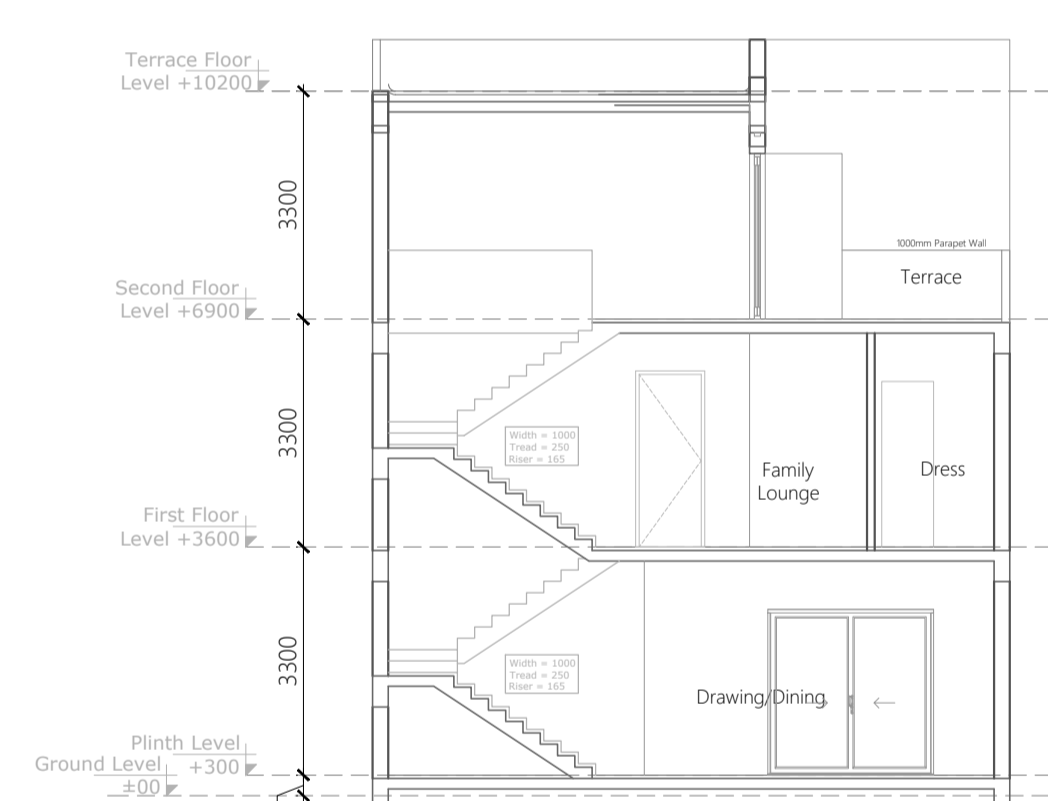

Section-A1
SCALE -1:100

Ground Floor Area Calculation

Tag	Description	Size	No.	Area Sq.mtr.	Remark
1	Rectangle	2.045 x 3.000	1	6.135	Sq.mtr.
2	Rectangle	3.000 x 3.000	1	9.000	Sq.mtr.
3	Rectangle	3.025 x 3.000	1	9.075	Sq.mtr.
Total				15.210	Sq.mtr.

First Floor Area Calculation

Tag	Description	Size	No.	Area Sq.mtr.	Remark
1	Rectangle	3.000 x 3.000	1	9.000	Sq.mtr.
2	Rectangle	3.025 x 2.400	1	7.260	Sq.mtr.
Total				16.260	Sq.mtr.

Second Floor Area Calculation

Tag	Description	Size	No.	Area Sq.mtr.	Remark
1	Rectangle	3.025 x 3.025	1	9.151	Sq.mtr.
2	Rectangle	3.025 x 3.000	1	9.075	Sq.mtr.
Total				18.226	Sq.mtr.

Area For Deduction

Tag	Description	Size	No.	Area Sq.mtr.	Remark
1	Rectangle	3.025 x 3.025	1	9.151	Sq.mtr.
2	Rectangle	3.025 x 3.000	1	9.075	Sq.mtr.
Total				18.226	Sq.mtr.

Total F.A.R. Area at Ground Floor (K1)

Tag	Description	Size	No.	Area Sq.mtr.	Remark
1	Rectangle	3.000 x 3.000	1	9.000	Sq.mtr.
2	Rectangle	3.025 x 2.400	1	7.260	Sq.mtr.
Total				16.260	Sq.mtr.

Total F.A.R. Area at First Floor (K2)

Tag	Description	Size	No.	Area Sq.mtr.	Remark
1	Rectangle	3.000 x 3.000	1	9.000	Sq.mtr.
2	Rectangle	3.025 x 2.400	1	7.260	Sq.mtr.
Total				16.260	Sq.mtr.

Total F.A.R. Area at Second Floor (K3)

Tag	Description	Size	No.	Area Sq.mtr.	Remark
1	Rectangle	3.025 x 3.025	1	9.151	Sq.mtr.
2	Rectangle	3.025 x 3.000	1	9.075	Sq.mtr.
Total				18.226	Sq.mtr.

DOOR - WINDOW SCHEDULE

S. No.	Type	Size	Remark
1	DW1	2400x2400	Door/ Window
2	DW2	1800x2400	Door/ Window
3	DW2	1370x2400	Door/ Window
4	D1	1500x2400	Door
5	D2	1000x2400	Door
6	D3	900x2400	Door
7	D4	750x2400	Door
8	W1	1200x1500	Window
9	W2	750x1200	Window

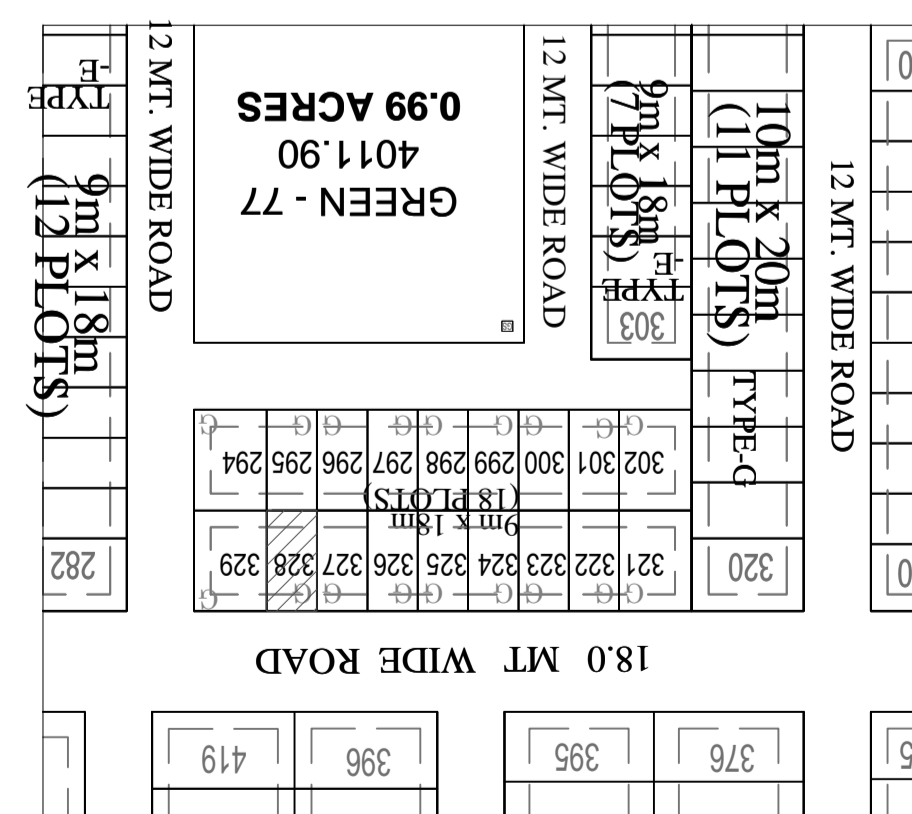

KEY PLAN
SCALE -1:100

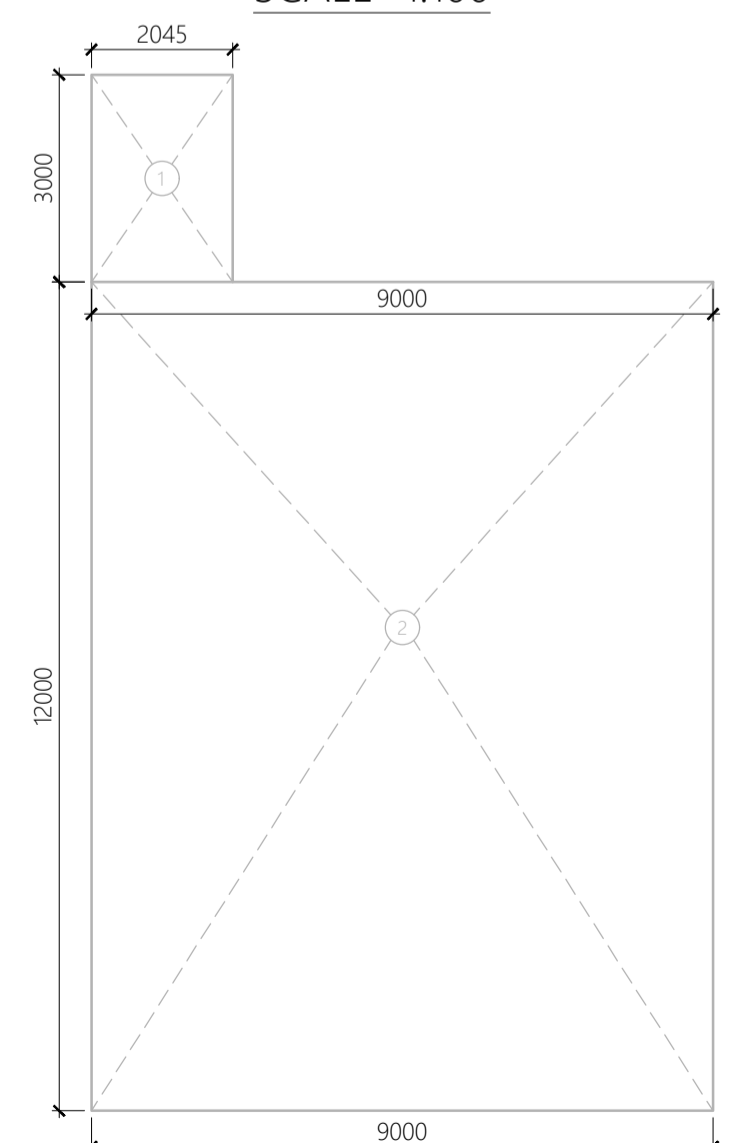

Area Envelope Plan of
Ground Floor

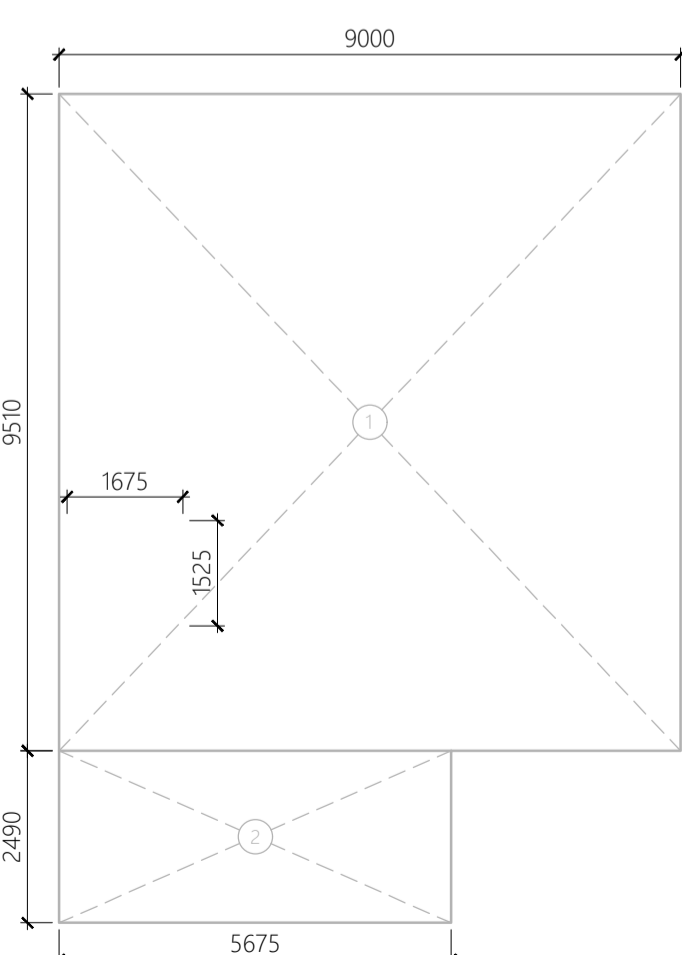

Area Envelope Plan of
First Floor

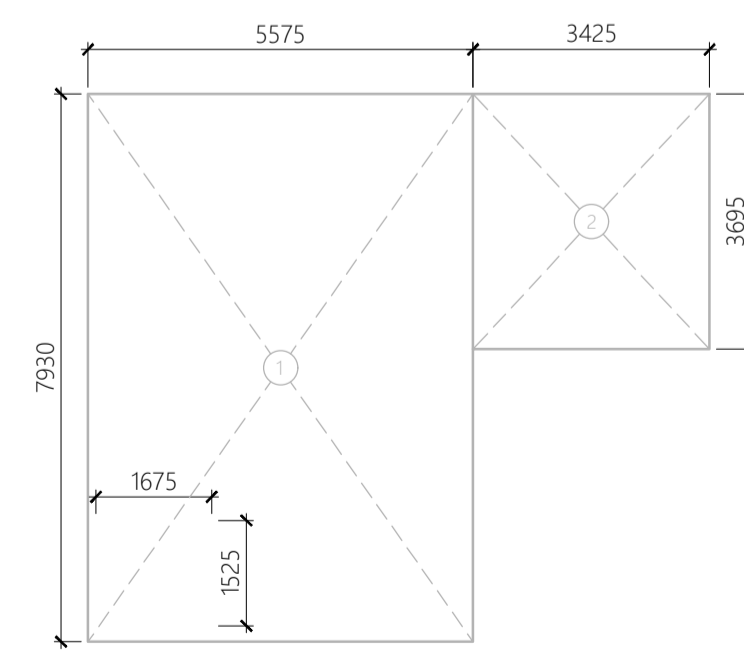

Area Envelope Plan of
Second Floor



Lucknow Development Authority

FOR OFFICE :-

PROJECT TITLE-

**PROPOSED RESIDENTIAL
SUBMISSION DRAWING FOR THE
VILLA ON PLOT NO - 300 P1
POCKET - L TYPE- E OMAXE
HI-TECH CITY AT LUCKNOW**

AREA STATEMENT

S.NO.	PARTICULARS	SQ.MTR.
1.	PLOT AREA	162.0
2.	PERMISSIBLE GROUND FLOOR COVERAGE (65%)	105.300
3.	PROPOSED GROUND COVERAGE(64.19%)	104.00
4.	PROPOSED FIRST FLOOR AREA	97.166
5.	PROPOSED SECOND FLOOR AREA	56.865
6.	PROPOSED TERRACE FLOOR AREA	0.0
7.	PROPOSED PORCH AREA	10.08
8.	PERMISSIBLE F. A. R. (2.0)	324.00
9.	PROPOSED F. A. R. = [G.F. + F.F.+S.F.](1.592)	258.031
10.	TOTAL COVERED AREA (3+4+5+6+7)	268.11

NOTE :- ALL DIMENSIONS ARE IN MM

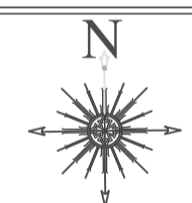

PROJECT ADDRESS:-

**VILLA (9.0MX18.0M) IN
OMAXE HITECH CITY , LUCKNOW U.P.**

OWNER NAME:-

OMAXE GARV BUILDTech PVT LIMITED

This drawing is a "COPYRIGHT" contents of this drawing or part thereof may not be used or reproduced without the permission of the Architect

OWNER SIGNATURE



ARCHITECT SIGNATURE

Sachin Yadav
Ar. Sachin Yadav
CA/2021/140419

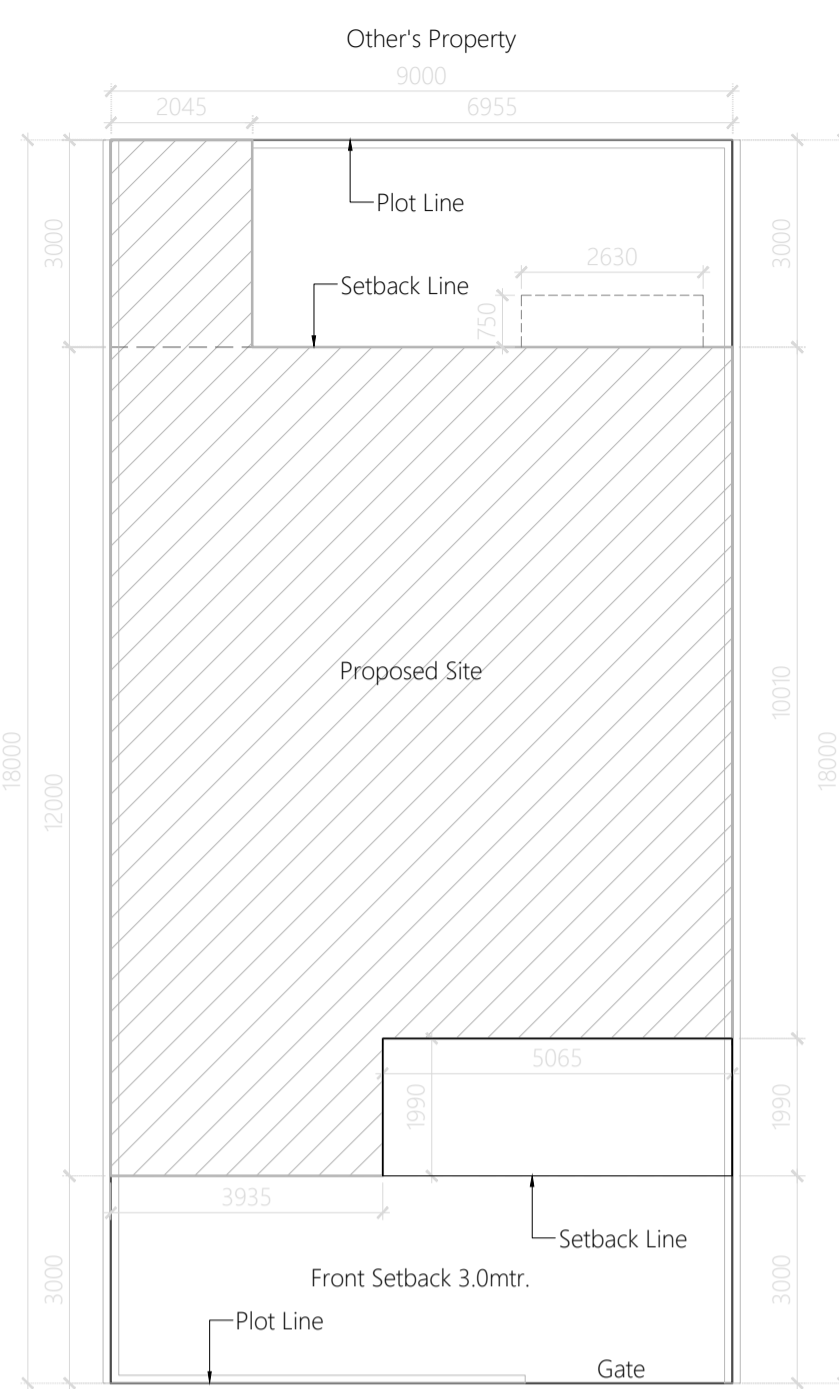

Site Plan
SCALE -1:100

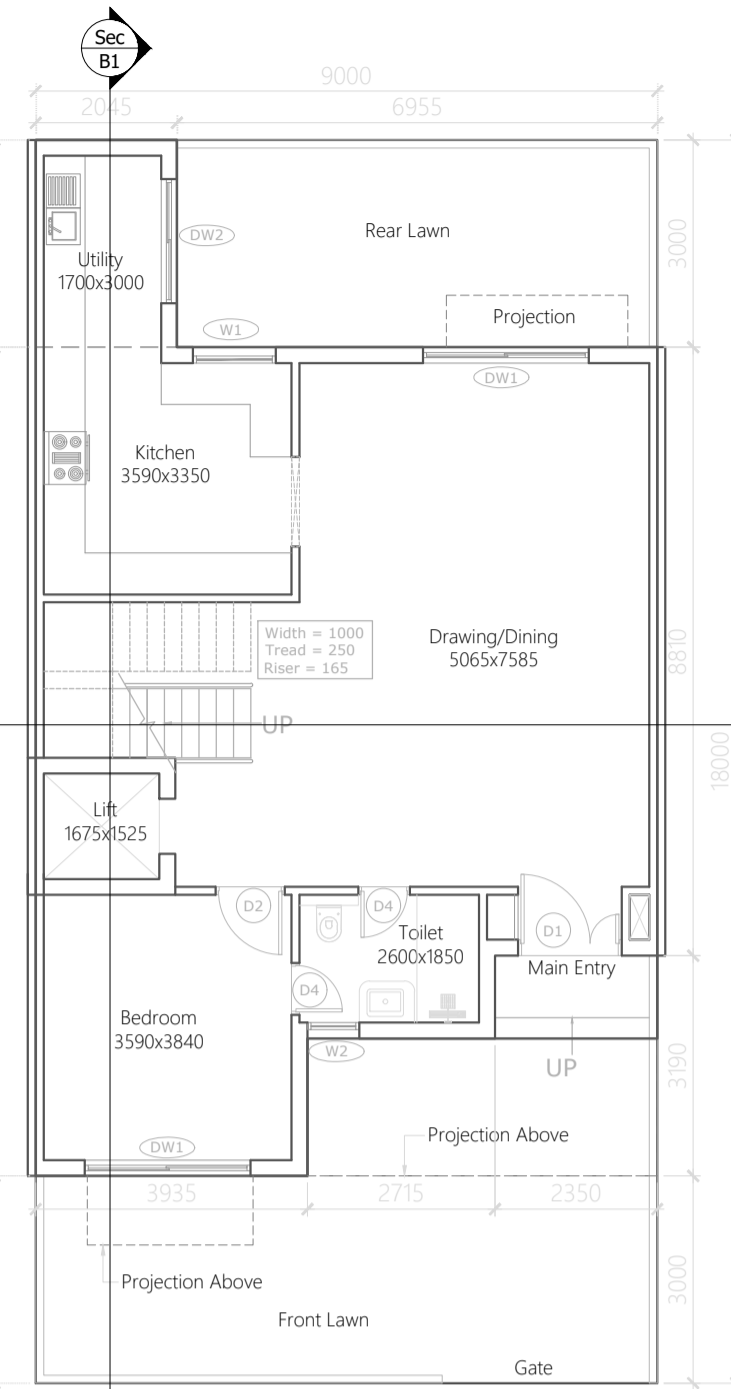

Ground Floor Plan
SCALE -1:100

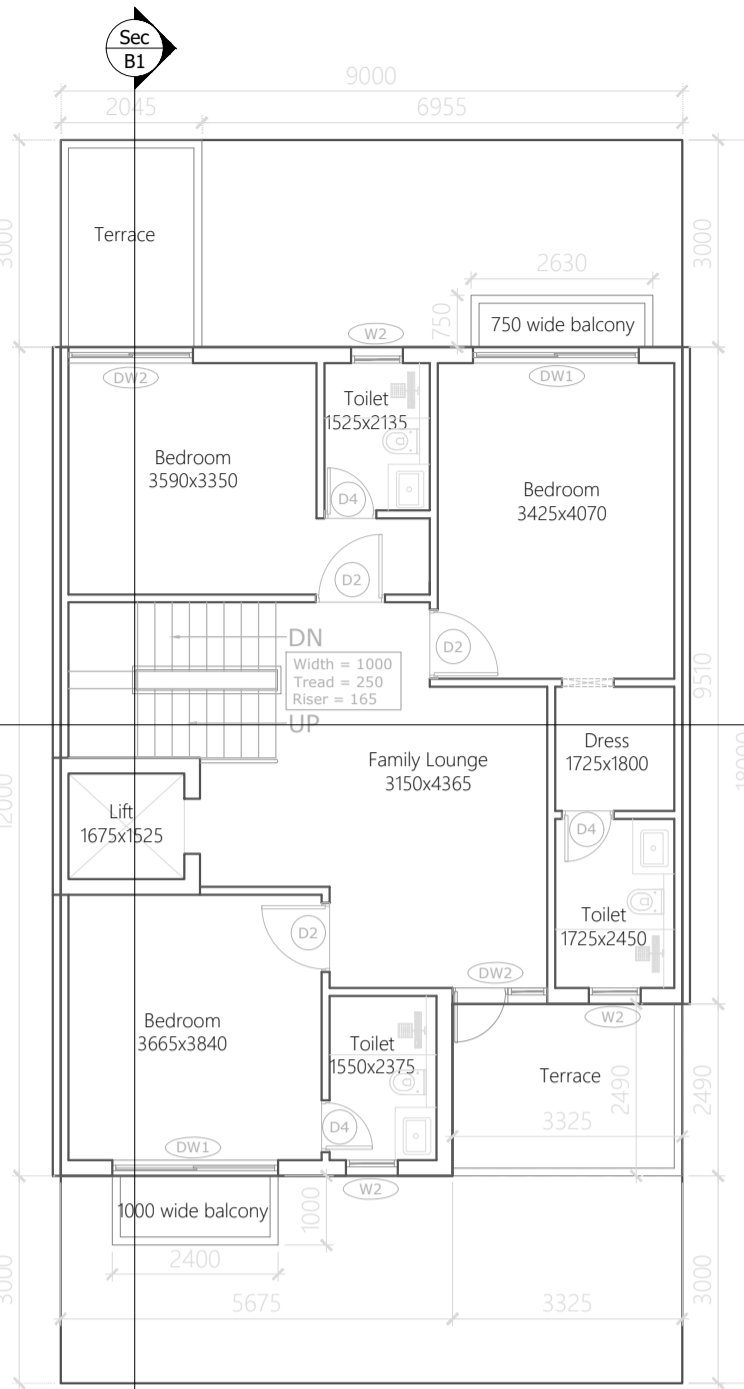

First Floor Plan
SCALE -1:100

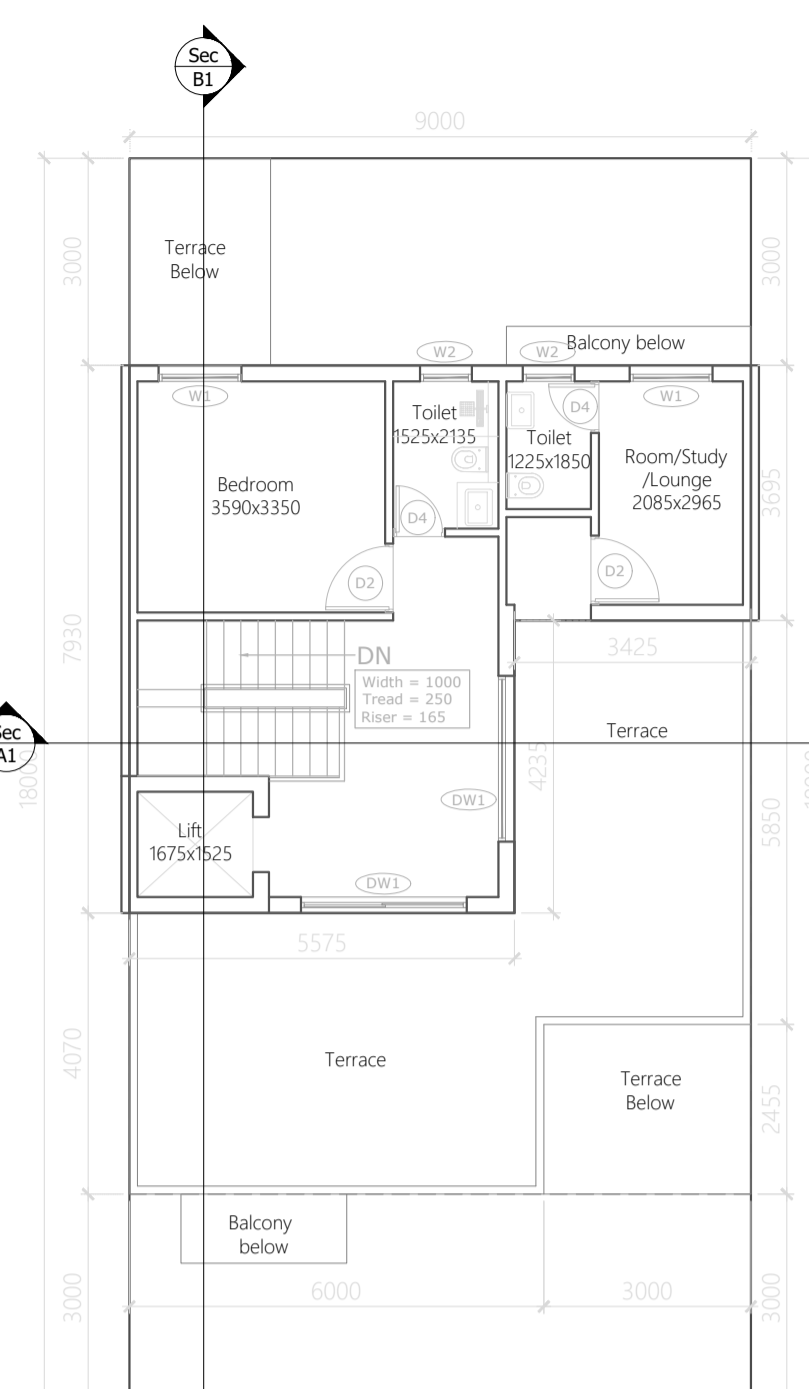

Second Floor Plan
SCALE -1:100

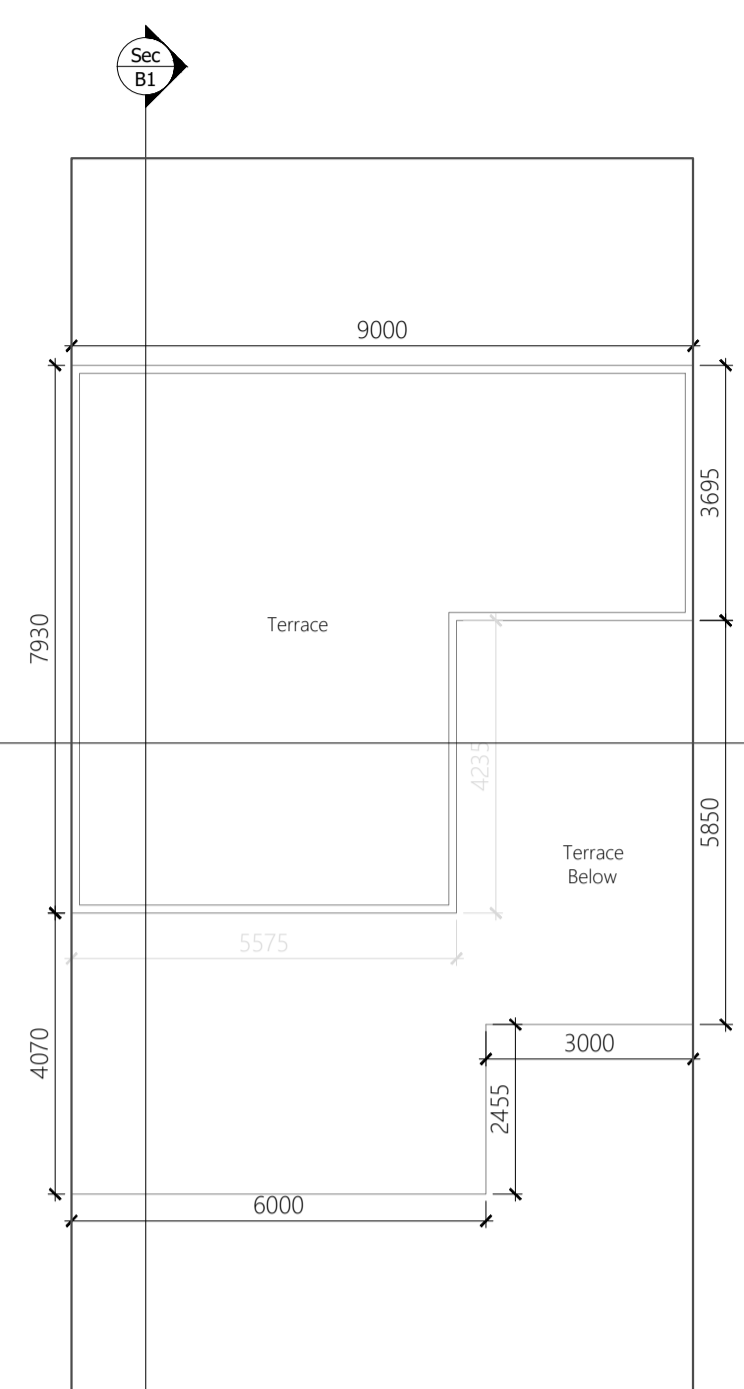

TERRACE Floor Plan
SCALE -1:100



Front Elevation
SCALE -1:100



Section-B1
SCALE -1:100

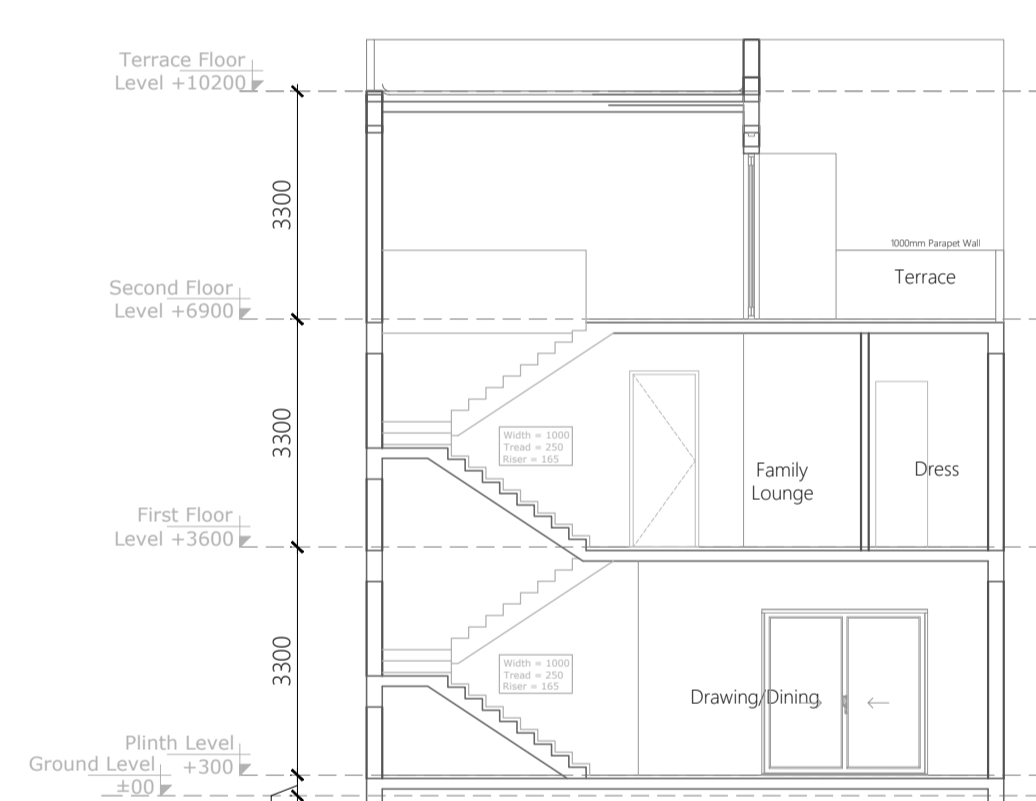

Section-A1
SCALE -1:100

Ground Floor Area Calculation

Tag	Description	Size	No.	Area Sq.mtr.	Remark
1	Rectangle	2.045 x 1.000	1	2.045	X1
2	Rectangle	3.000 x 1.000	1	3.000	X1
3	Rectangle	3.935 x 1.990	1	7.831	X1
Total				12.876	

First Floor Area Calculation

Tag	Description	Size	No.	Area Sq.mtr.	Remark
1	Rectangle	3.000 x 1.525	1	4.575	X1
2	Rectangle	3.075 x 2.400	1	7.380	X1
Total				11.955	

Area For Deduction

Tag	Description	Size	No.	Area Sq.mtr.	Remark
1	Rectangle	3.075 x 3.325	1	10.223	X2
Total				10.223	

Total F.A.R. Area at First Floor (K1-K2)

Total F.A.R. Area at First Floor (K1-K2)	97.258	Sq.mtr.	X3
Non F.A.R. Area	0.000	Sq.mtr.	
Total Built-up Area at First Floor (K1)	97.258	Sq.mtr.	

Second Floor Area Calculation

Tag	Description	Size	No.	Area Sq.mtr.	Remark
1	Rectangle	3.375 x 2.900	1	9.788	X1
2	Rectangle	3.425 x 3.095	1	10.600	X1
Total				20.388	

Area For Deduction

Tag	Description	Size	No.	Area Sq.mtr.	Remark
1	Rectangle	3.075 x 3.325	1	10.223	X2
Total				10.223	

Total F.A.R. Area at Second Floor (K3-K2)

Total F.A.R. Area at Second Floor (K3-K2)	54.311	Sq.mtr.	X5
Non F.A.R. Area	0.000	Sq.mtr.	
Total Built-up Area at Second Floor (K3)	54.311	Sq.mtr.	

DOOR - WINDOW SCHEDULE

S. No.	Type	Size	Remark
1	DW1	2400x2400	Door/ Window
2	DW2	1800x2400	Door/ Window
3	DW2	1370x2400	Door/ Window
4	D1	1500x2400	Door
5	D2	1000x2400	Door
6	D3	900x2400	Door
7	D4	750x2400	Door
8	W1	1200x1500	Window
9	W2	750x1200	Window

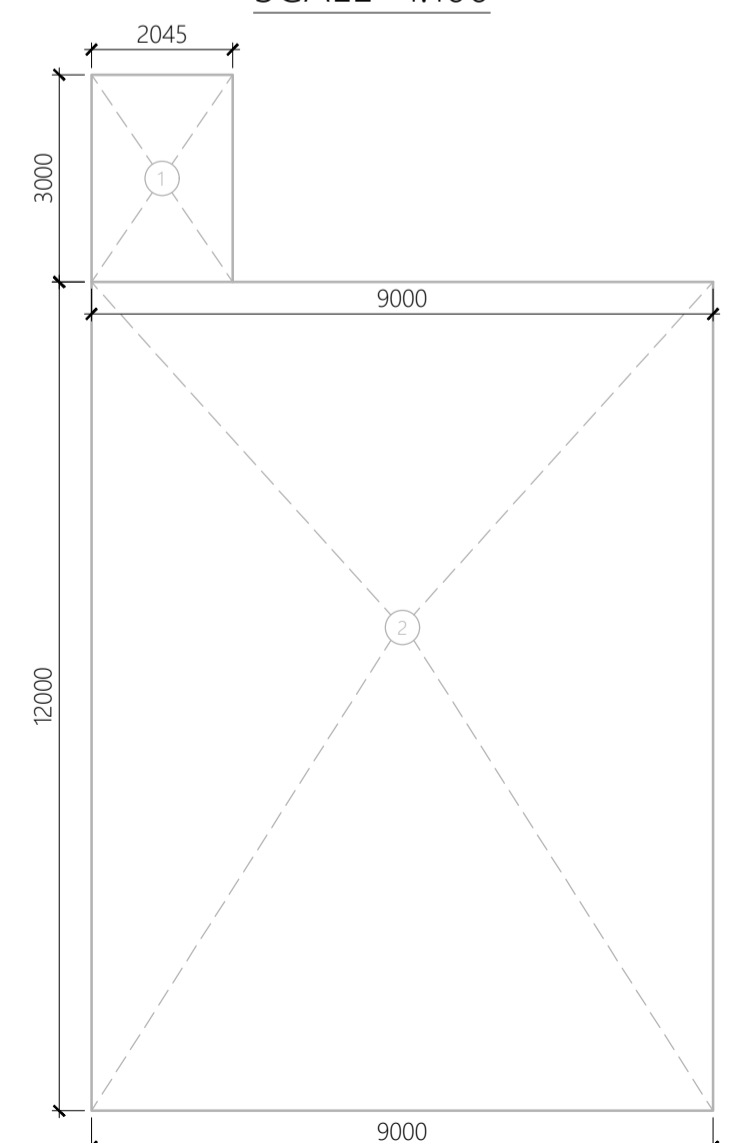

Area Envelope Plan of
Ground Floor

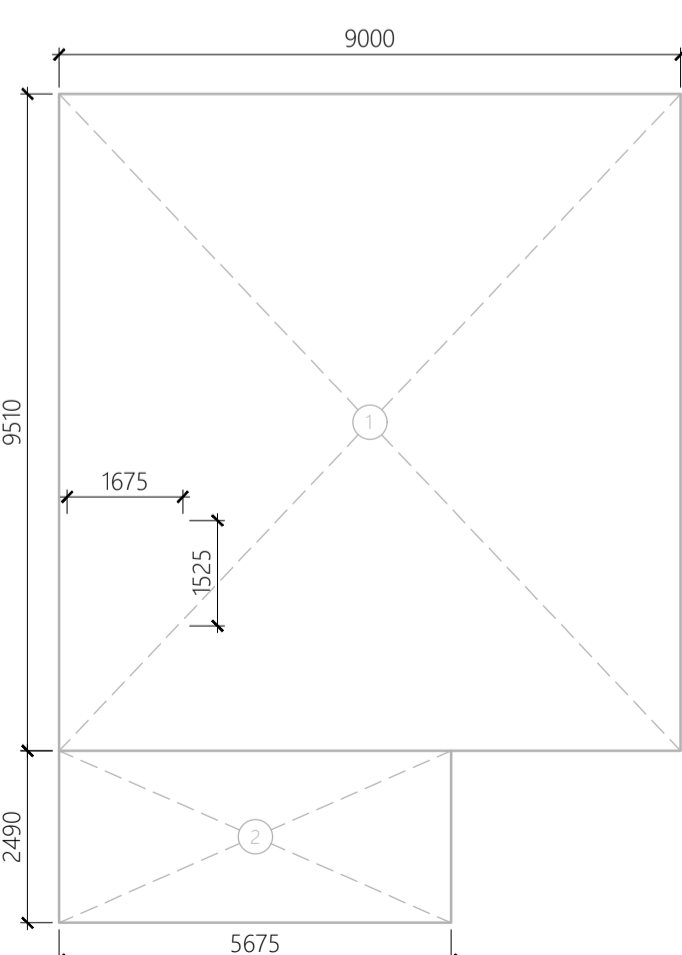

Area Envelope Plan of
First Floor

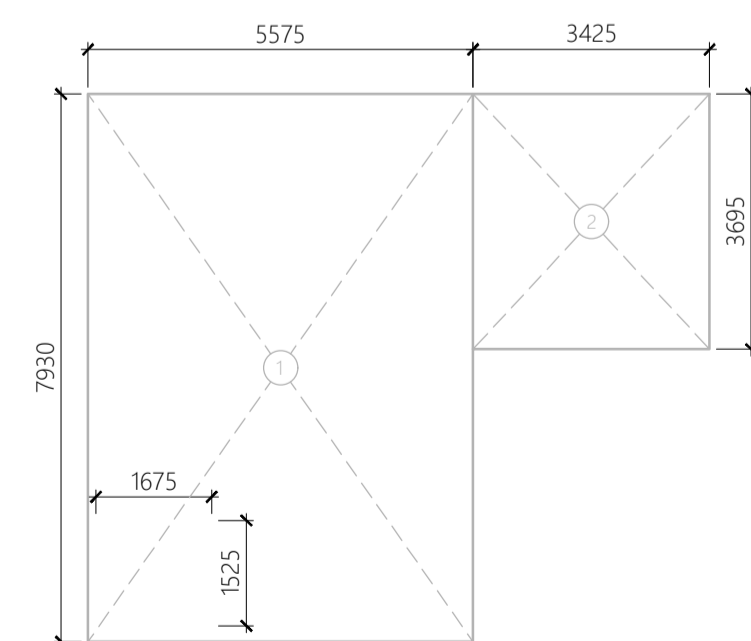

Area Envelope Plan of
Second Floor

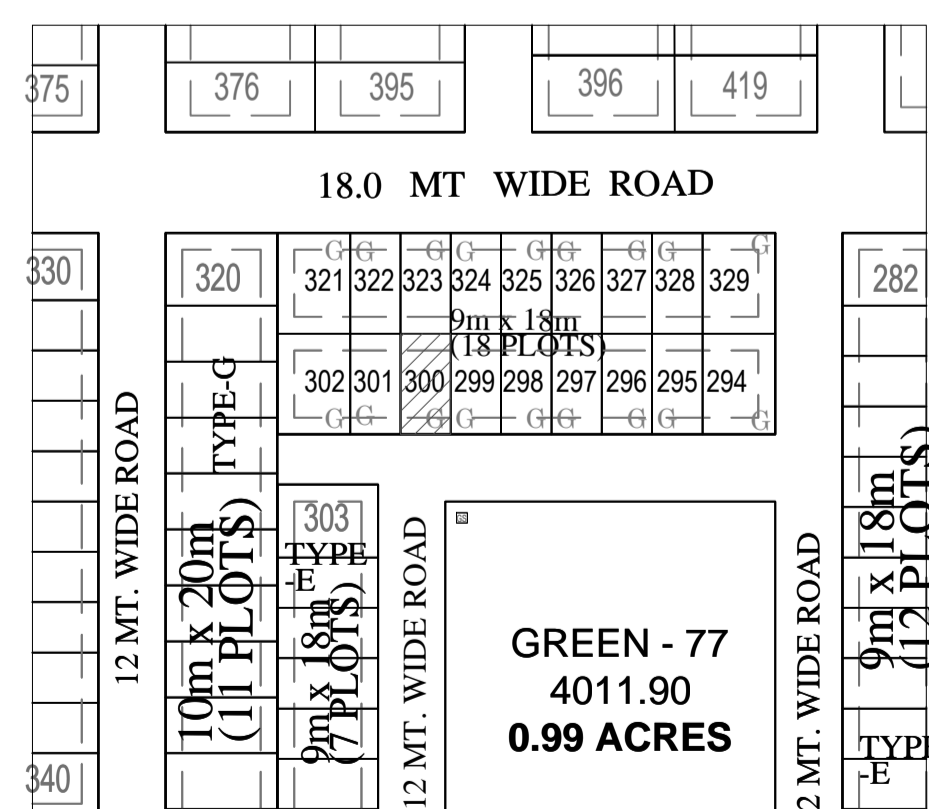

KEY PLAN
SCALE -1:100



Lucknow Development Authority

FOR OFFICE :-

PROJECT TITLE-

**PROPOSED RESIDENTIAL
SUBMISSION DRAWING FOR THE
VILLA ON PLOT NO - 301 P1
POCKET - L TYPE- E OMAXE HI-TECH
CITY AT LUCKNOW**

AREA STATEMENT

S.NO.	PARTICULARS	SQ.MTR.
1.	PLOT AREA	162.0
2.	PERMISSIBLE GROUND FLOOR COVERAGE (65%)	105.300
3.	PROPOSED GROUND COVERAGE(64.19%)	104.00
4.	PROPOSED FIRST FLOOR AREA	97.166
5.	PROPOSED SECOND FLOOR AREA	56.865
6.	PROPOSED TERRACE FLOOR AREA	0.0
7.	PROPOSED PORCH AREA	10.08
8.	PERMISSIBLE F. A. R. (2.0)	324.00
9.	PROPOSED F. A. R. = [G.F. + F.F.+S.F](1.592)	258.031
10.	TOTAL COVERED AREA (3+4+5+6+7)	268.11

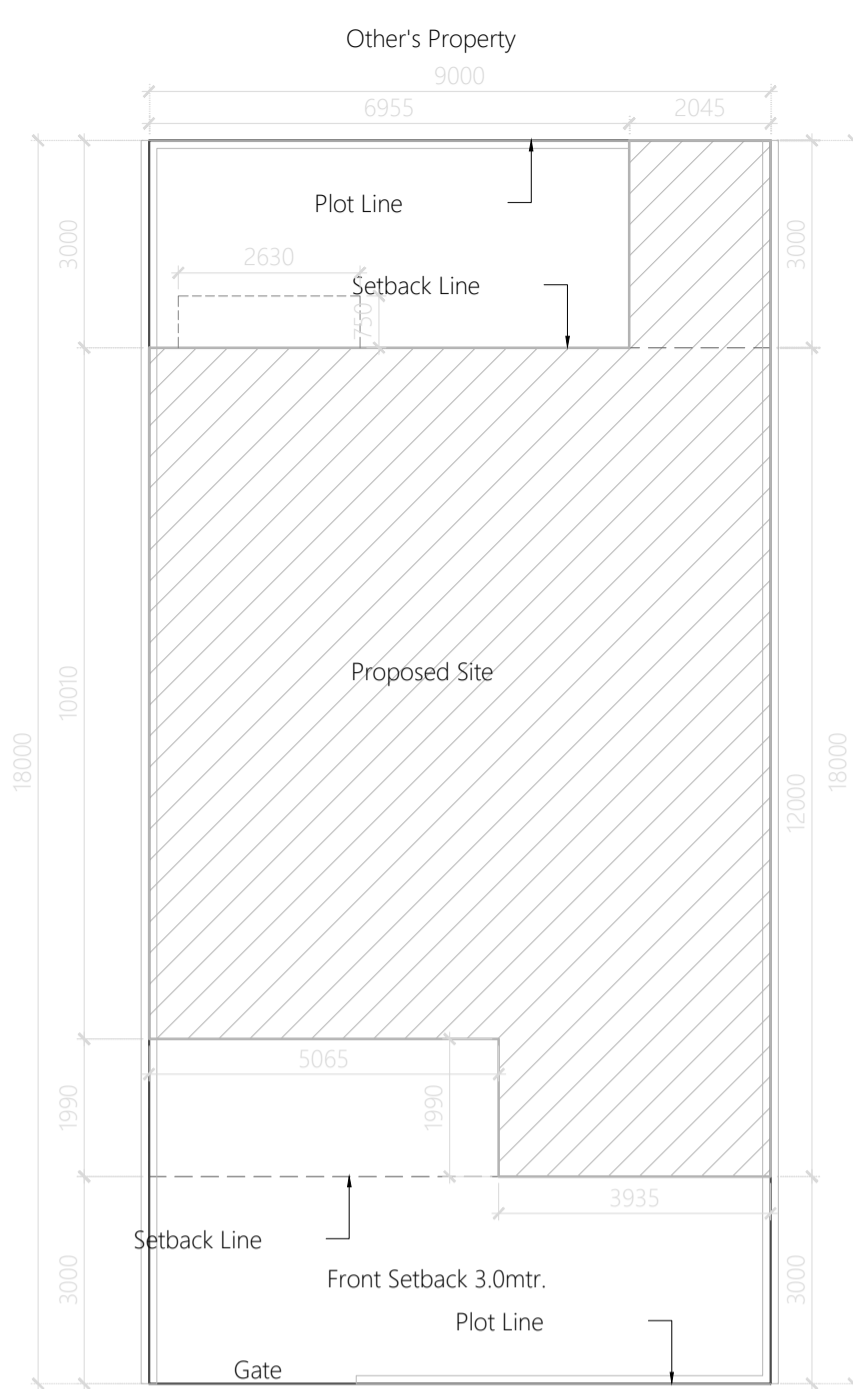

Site Plan
SCALE -1:100

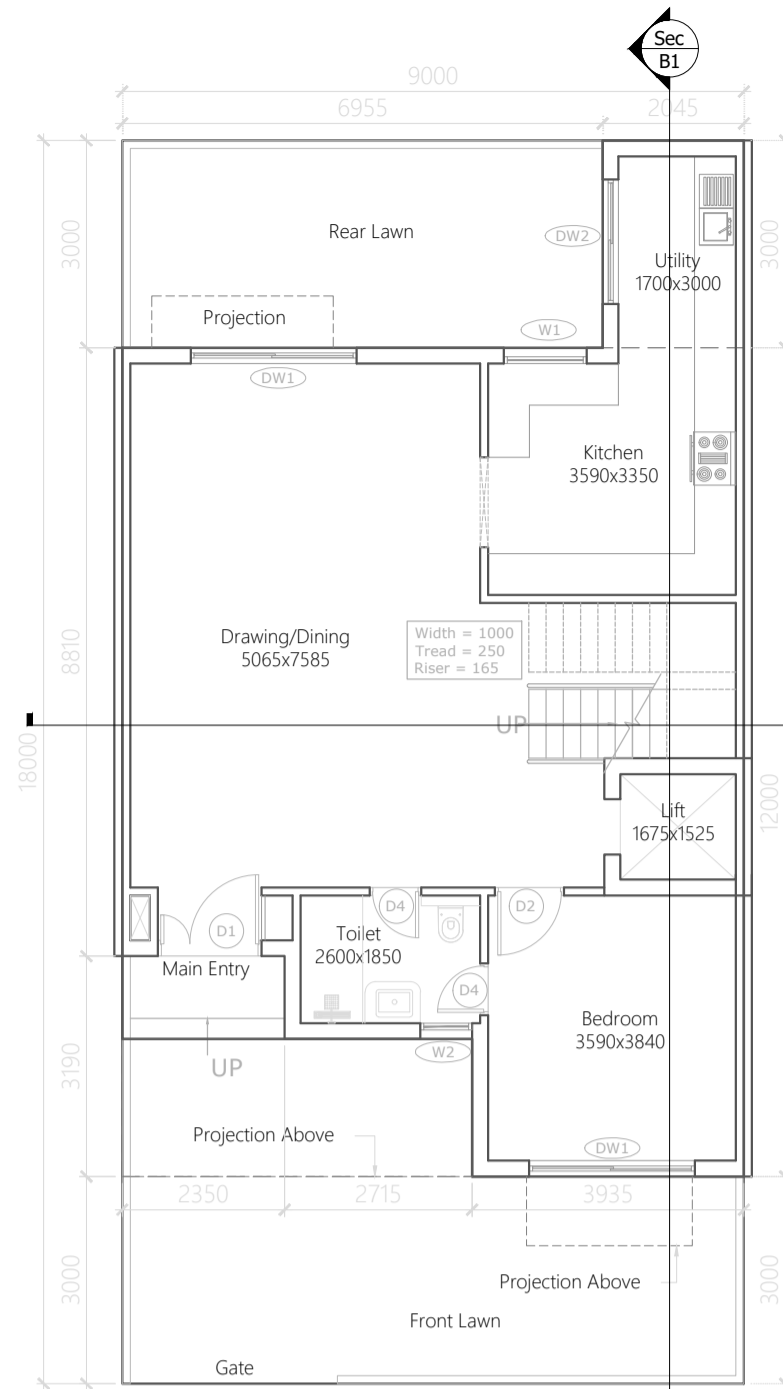

Ground Floor Plan
SCALE -1:100

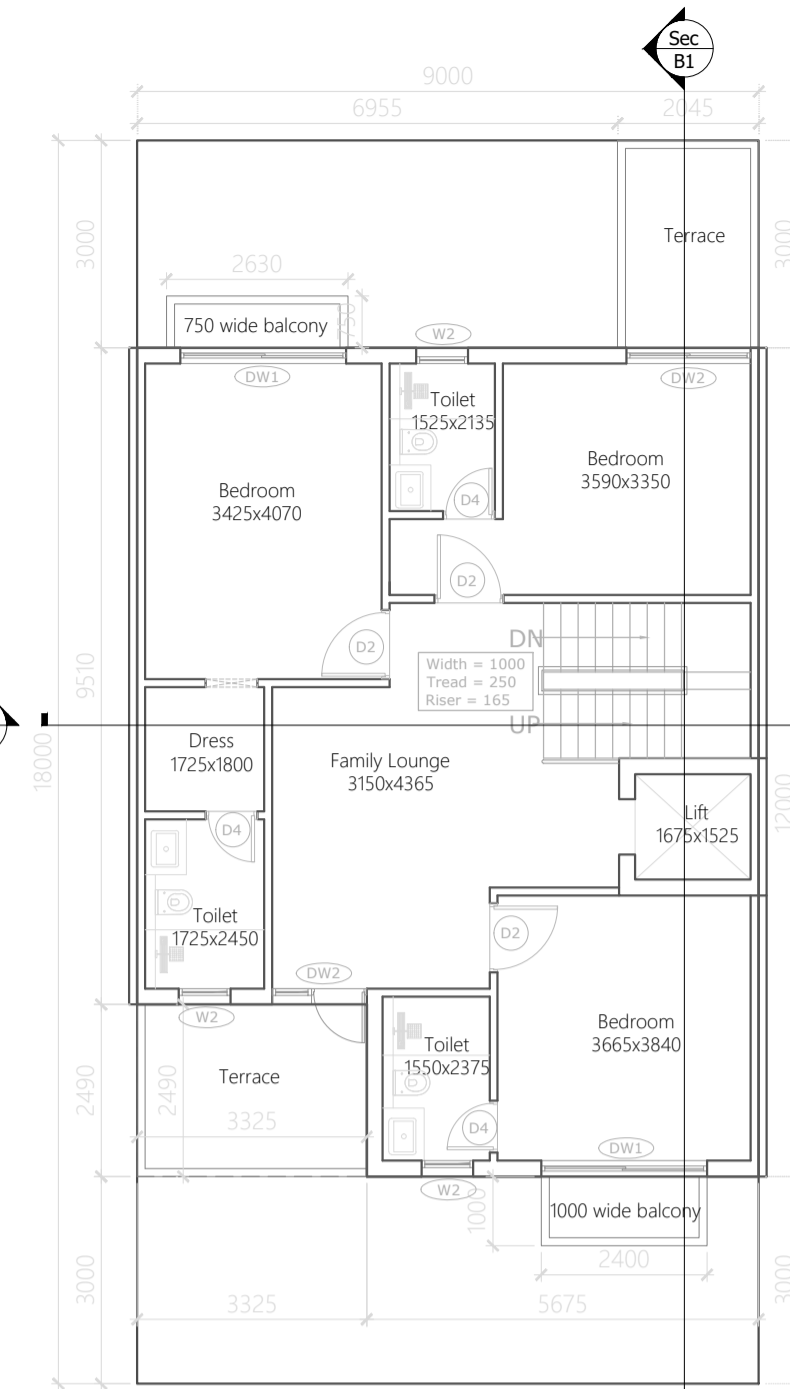

First Floor Plan
SCALE -1:100

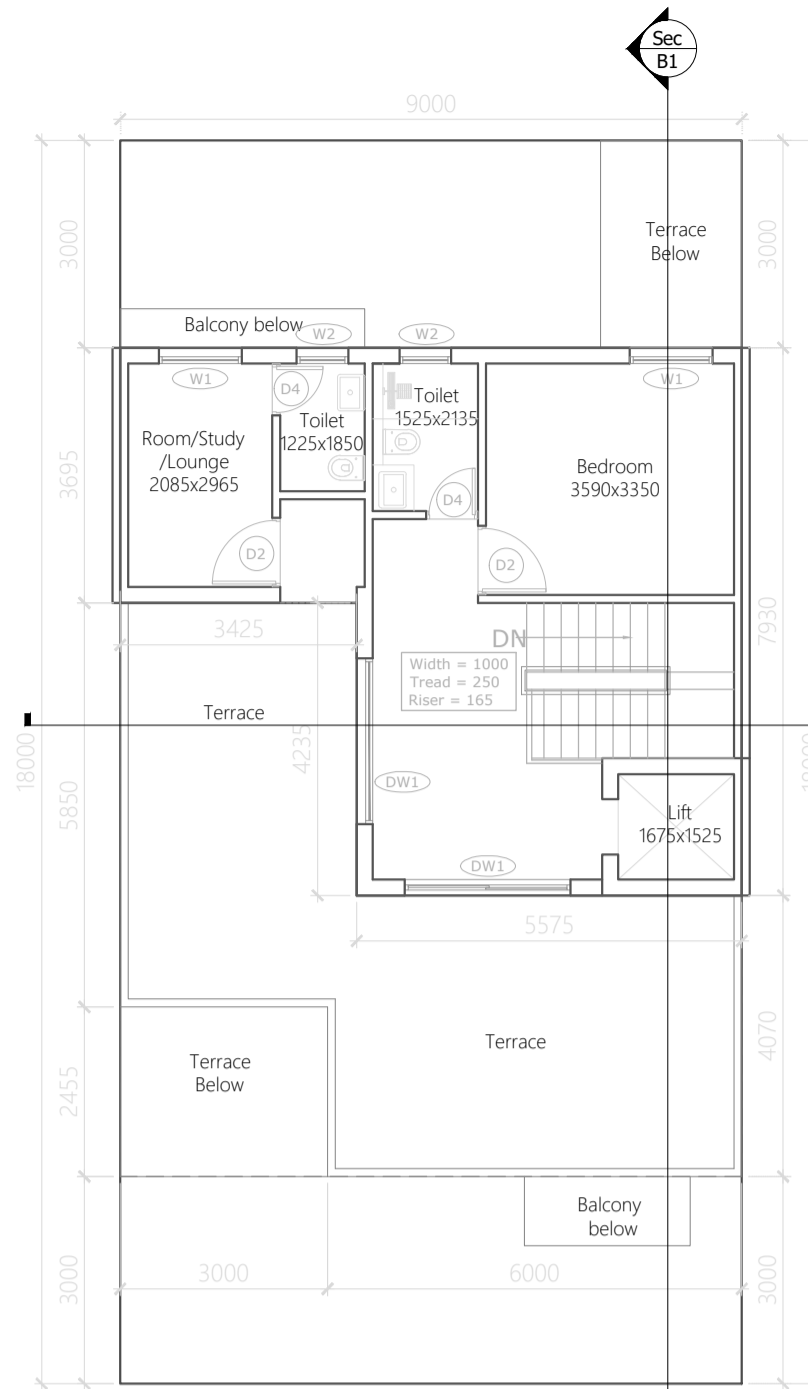

Second Floor Plan
SCALE -1:100

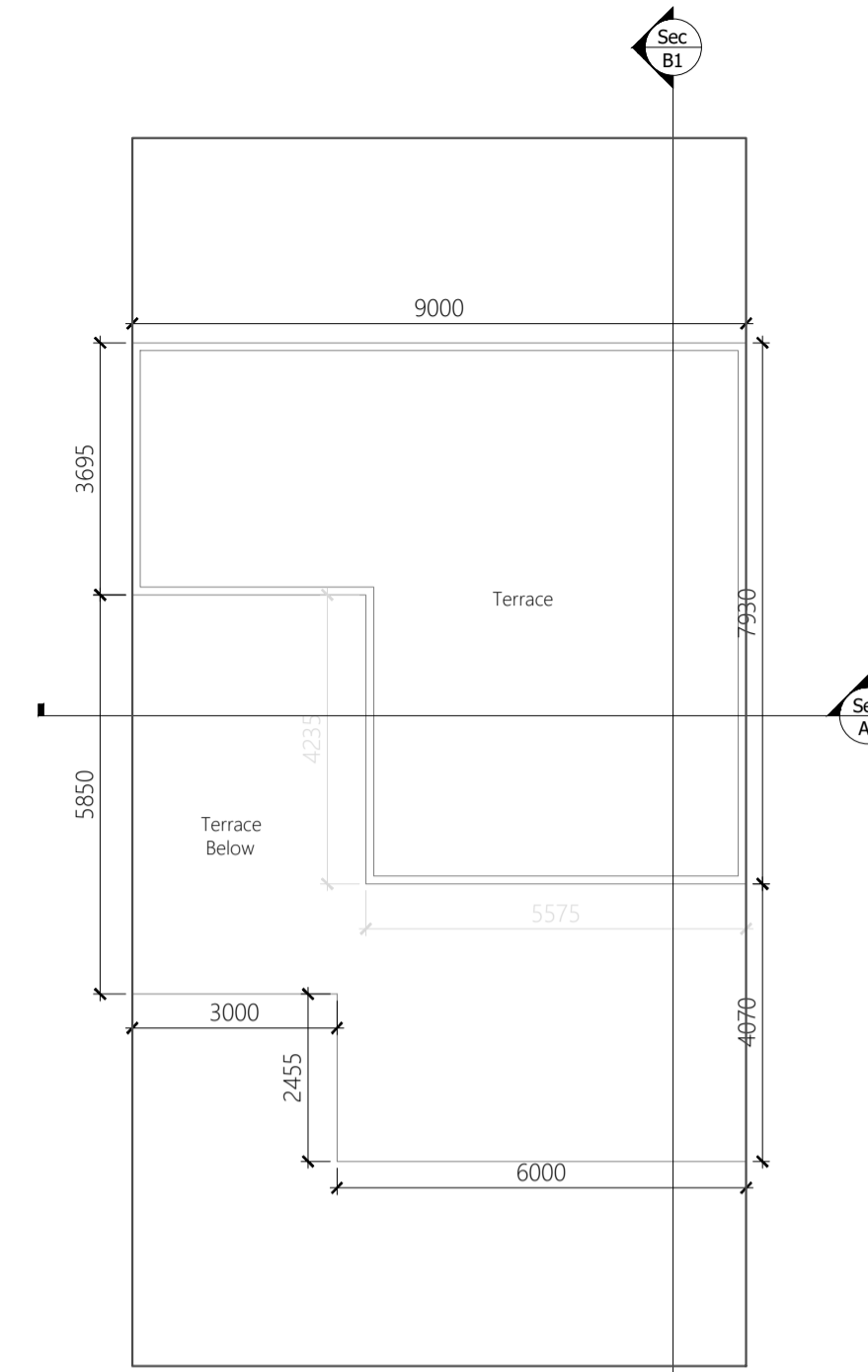

TERRACE Floor Plan
SCALE -1:100



Front Elevation
SCALE -1:100



Section-B1
SCALE -1:100

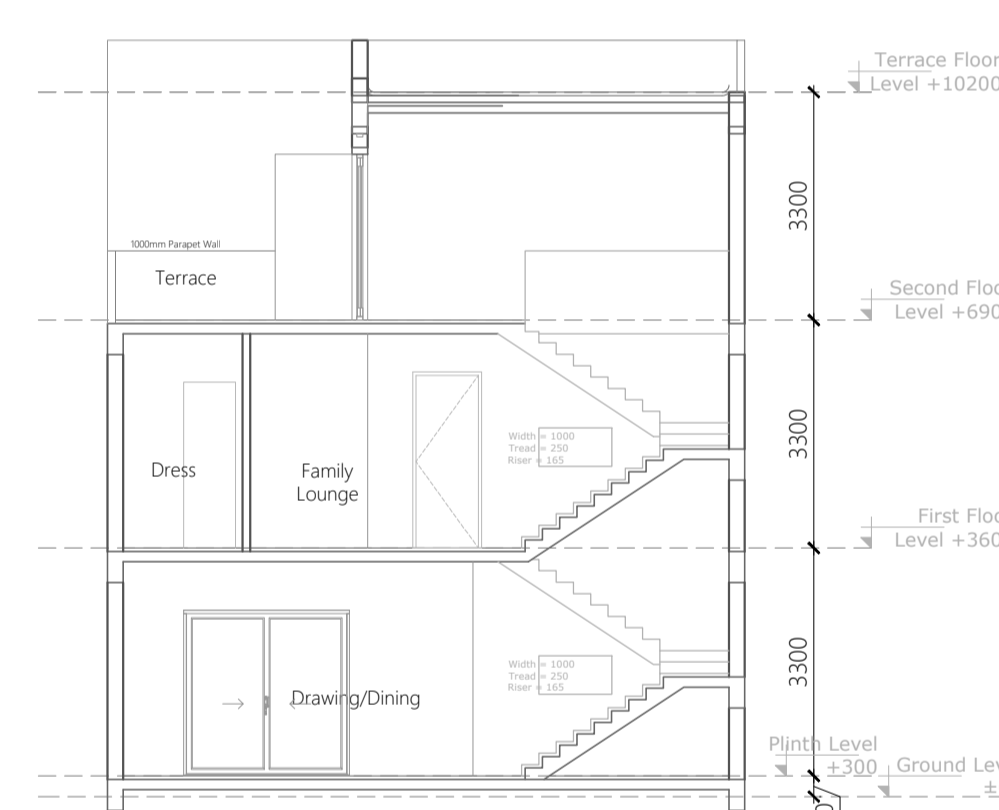

Section-A1
SCALE -1:100

Ground Floor Area Calculation				
Tag	Description	Size	Nos.	Area Sq. mtr.
1	Rectangle	2.045	3.000	6.135 Sq.mtr
2	Rectangle	9.000	10.100	90.900 Sq.mtr
3	Rectangle	3.935	1.990	7.831 Sq.mtr
Total				104.866 Sq.mtr

First Floor Area Calculation				
Tag	Description	Size	Nos.	Area Sq. mtr.
1	Rectangle	9.000	9.510	85.590 Sq.mtr
2	Rectangle	5.675	2.490	14.131 Sq.mtr
Total				99.721 Sq.mtr

Second Floor Area Calculation				
Tag	Description	Size	Nos.	Area Sq. mtr.
1	Rectangle	5.575	7.930	44.210 Sq.mtr
2	Rectangle	3.425	3.695	12.655 Sq.mtr
Total				56.865 Sq.mtr

NOTE :- ALL DIMENSIONS ARE IN MM

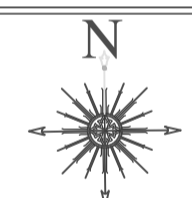

PROJECT ADDRESS:-

VILLA (9.0MX18.0M) IN
OMAXE HITECH CITY , LUCKNOW U.P.

OWNER NAME:-

OMAXE GARV BUILDTECH PVT LIMITED

This drawing is a "COPYRIGHT" contents of this drawing or part thereof may not be used or reproduced without the permission of the Architect

OWNER SIGNATURE



ARCHITECT SIGNATURE

Ar. Sachin Yadav
CA/2021/140419

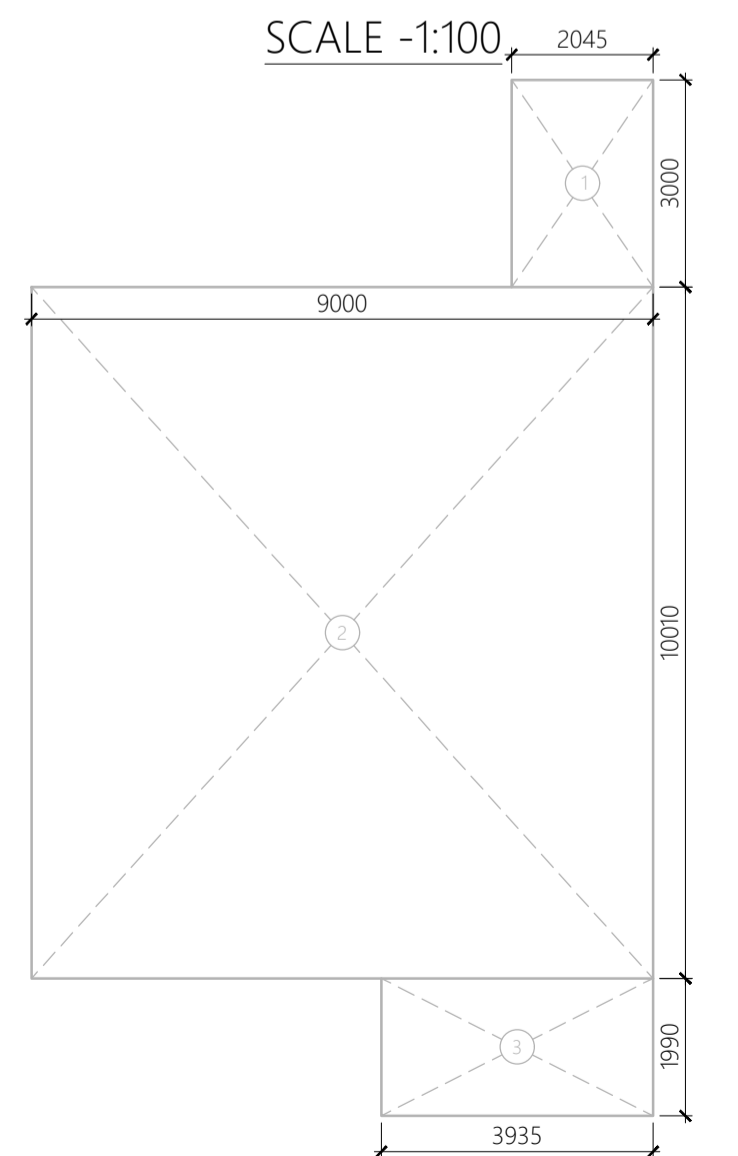

Area Envelope Plan of
Ground Floor

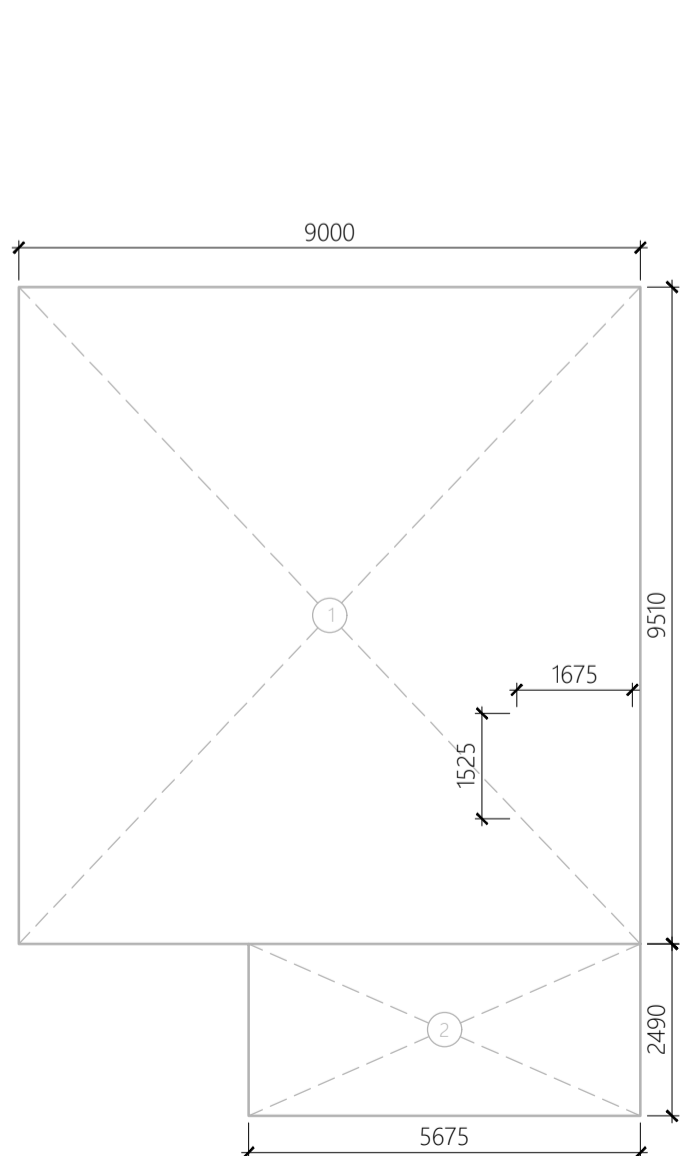

Area Envelope Plan of
First Floor

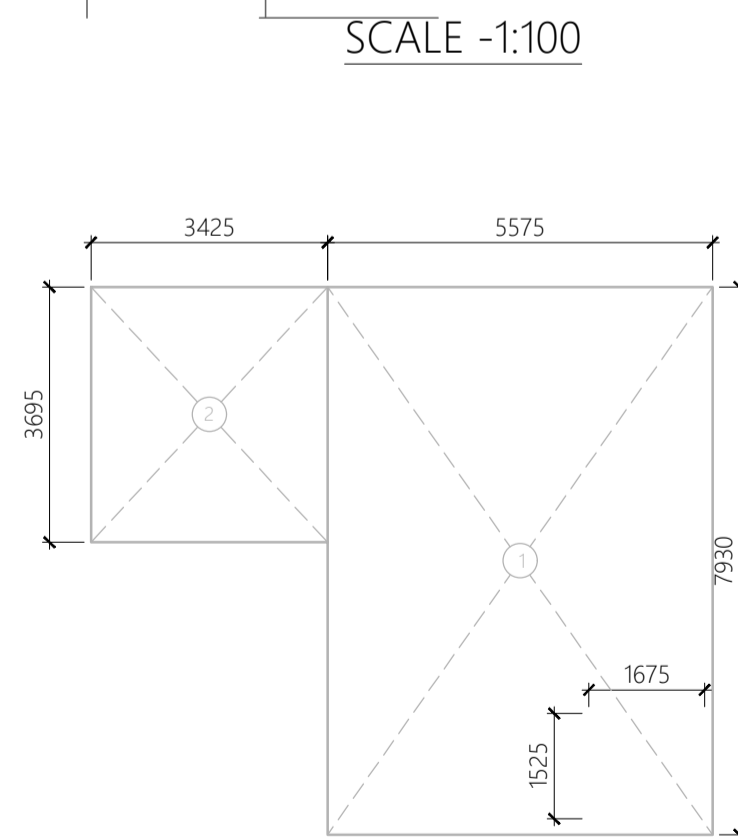

Area Envelope Plan of
Second Floor

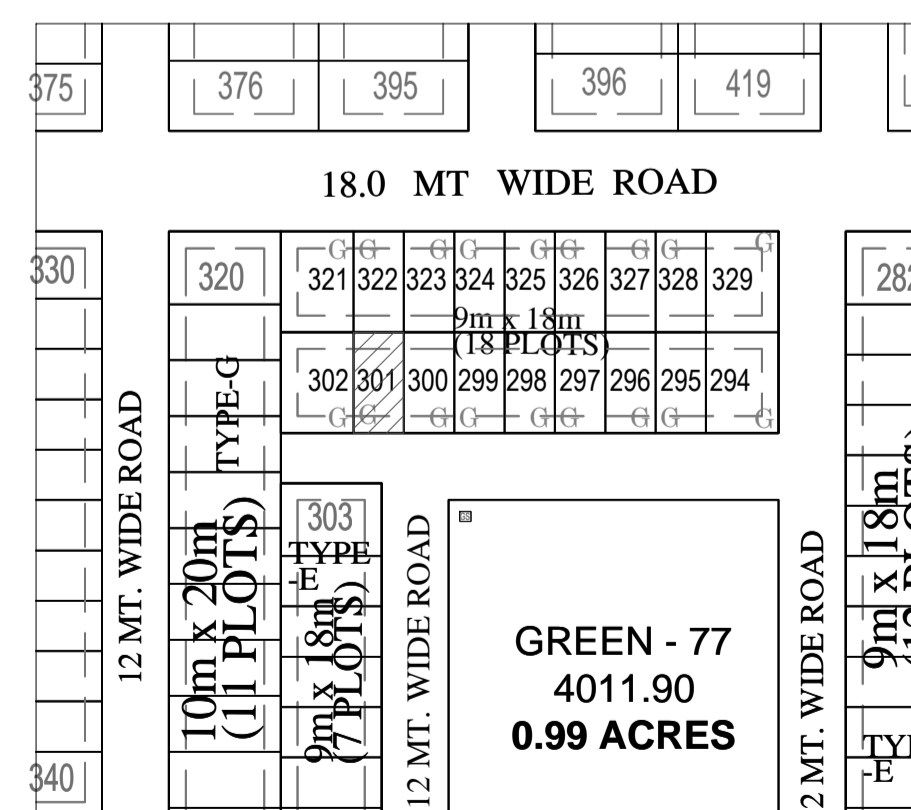

KEY PLAN
SCALE -1:100

DOOR - WINDOW SCHEDULE			
S. No.	Type	Size	Remark
1	DW1	2400x2400	Door/ Window
2	DW2	1800x2400	Door/ Window
3	DW2	1370x2400	Door/ Window
4	D1	1500x2400	Door
5	D2	1000x2400	Door
6	D3	900x2400	Door
7	D4	750x2400	Door
8	W1	1200x1500	Window
9	W2	750x1200	Window



FOR OFFICE :-

PROJECT TITLE-

**PROPOSED RESIDENTIAL
SUBMISSION DRAWING FOR THE
VILLA ON PLOT NO - 322 P1
POCKET - L TYPE- E OMAXE
HI-TECH CITY AT LUCKNOW**

AREA STATEMENT

S.NO.	PARTICULARS	SQ.MTR.
1.	PLOT AREA	162.0
2.	PERMISSIBLE GROUND FLOOR COVERAGE (65%)	105.300
3.	PROPOSED GROUND COVERAGE(64.19%)	104.00
4.	PROPOSED FIRST FLOOR AREA	97.166
5.	PROPOSED SECOND FLOOR AREA	56.865
6.	PROPOSED TERRACE FLOOR AREA	0.0
7.	PROPOSED PORCH AREA	10.08
8.	PERMISSIBLE F. A. R. (2.0)	324.00
9.	PROPOSED F. A. R. = [G.F. + F.F.+S.F.](1.592)	258.031
10.	TOTAL COVERED AREA (3+4+5+6+7)	268.11

NOTE :- ALL DIMENSIONS ARE IN MM

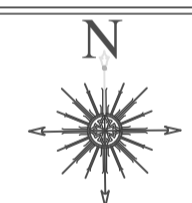

PROJECT ADDRESS:-

**VILLA (9.0MX18.0M) IN
OMAXE HITECH CITY , LUCKNOW U.P.**

OWNER NAME:-

OMAXE GARV BUILDTech PVT LIMITED

This drawing is a "COPYRIGHT" contents of this drawing or part thereof may not be used or reproduced without the permission of the Architect

OWNER SIGNATURE



ARCHITECT SIGNATURE

Sachin Yadav
Ar. Sachin Yadav
CA/2021/140419

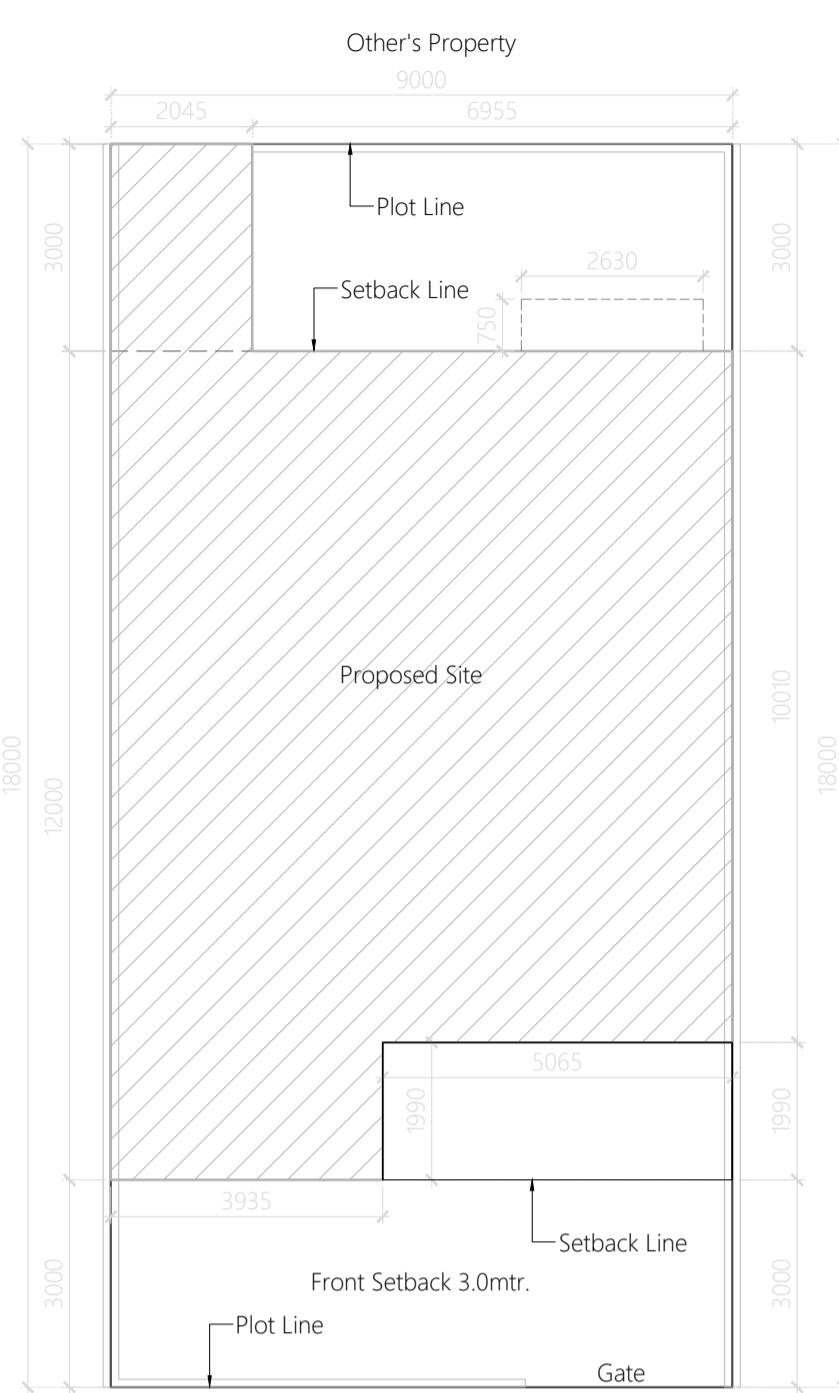

Site Plan
SCALE -1:100

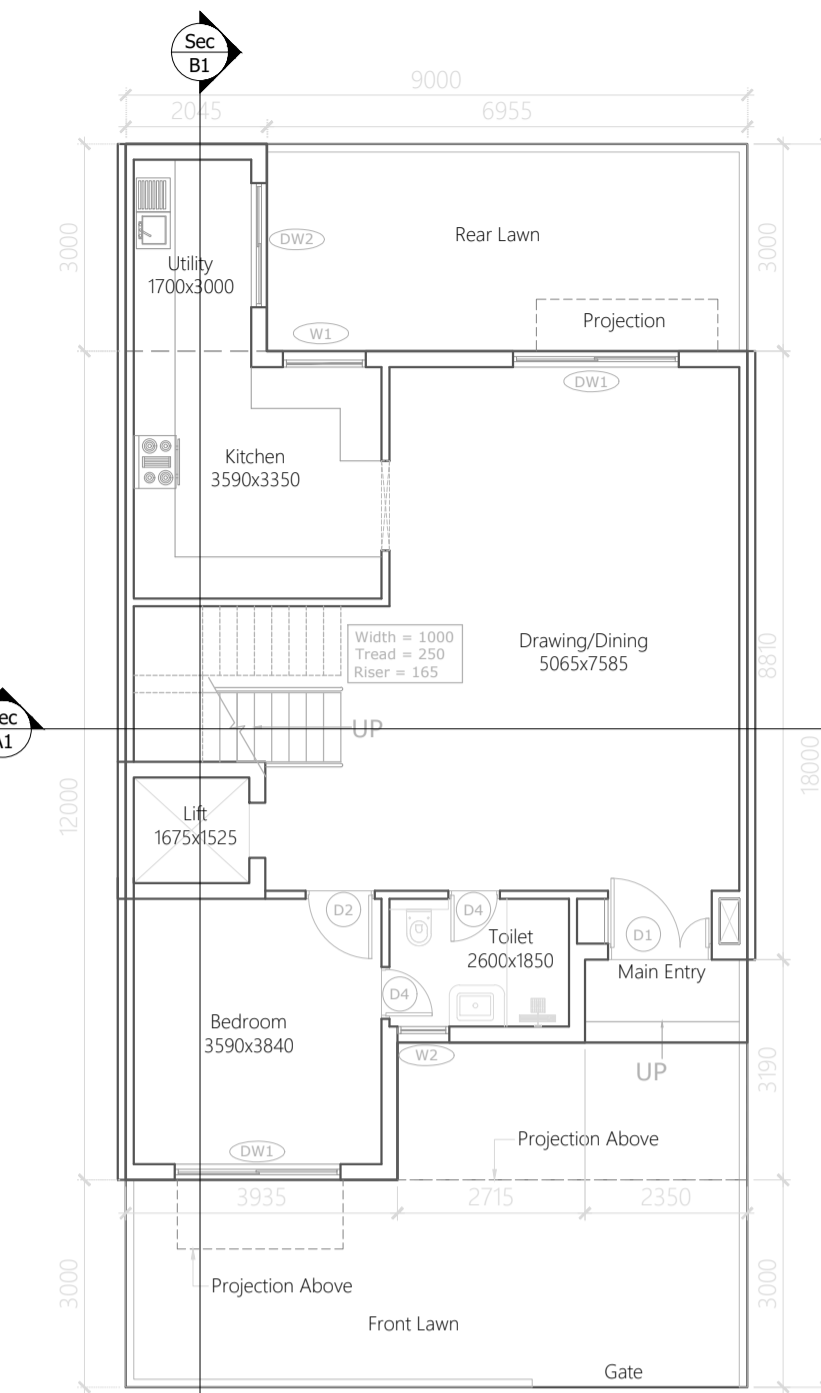

Ground Floor Plan
SCALE -1:100

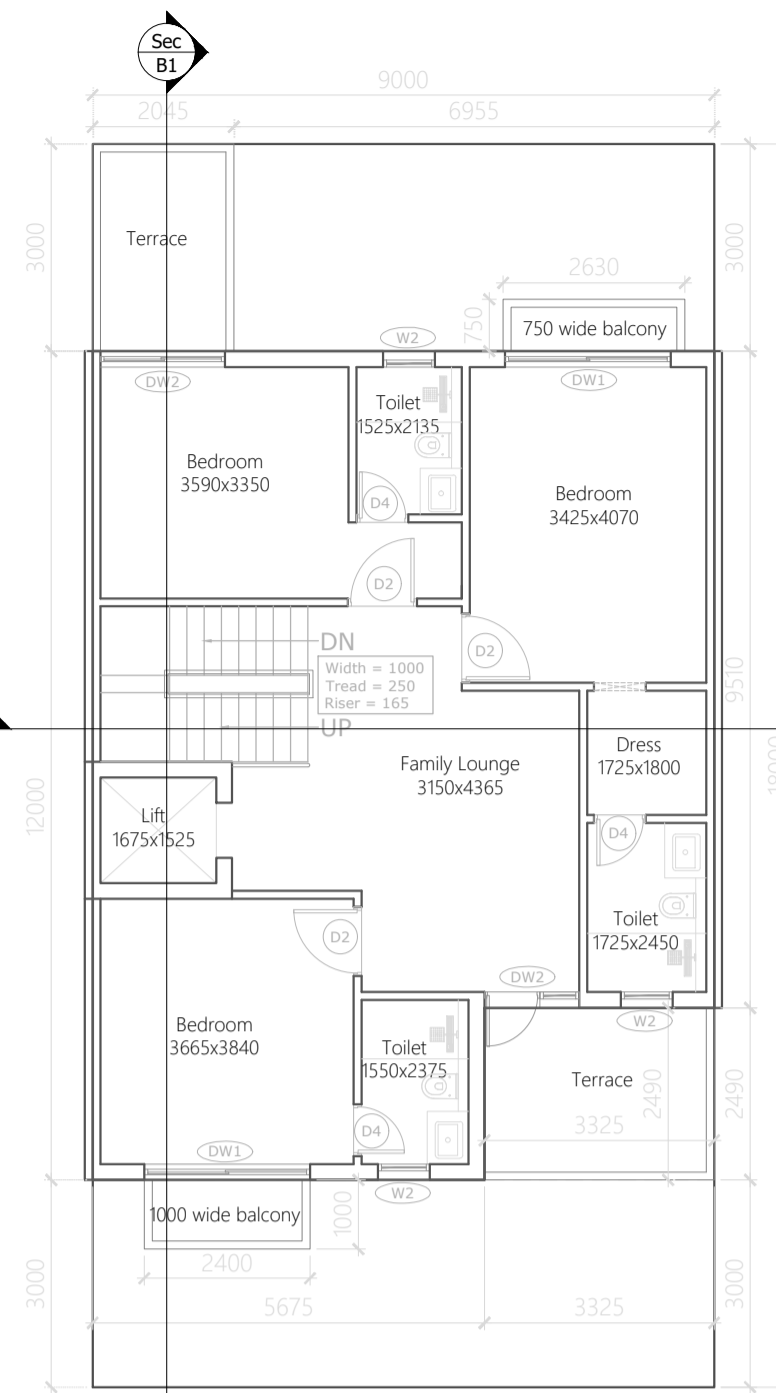

First Floor Plan
SCALE -1:100

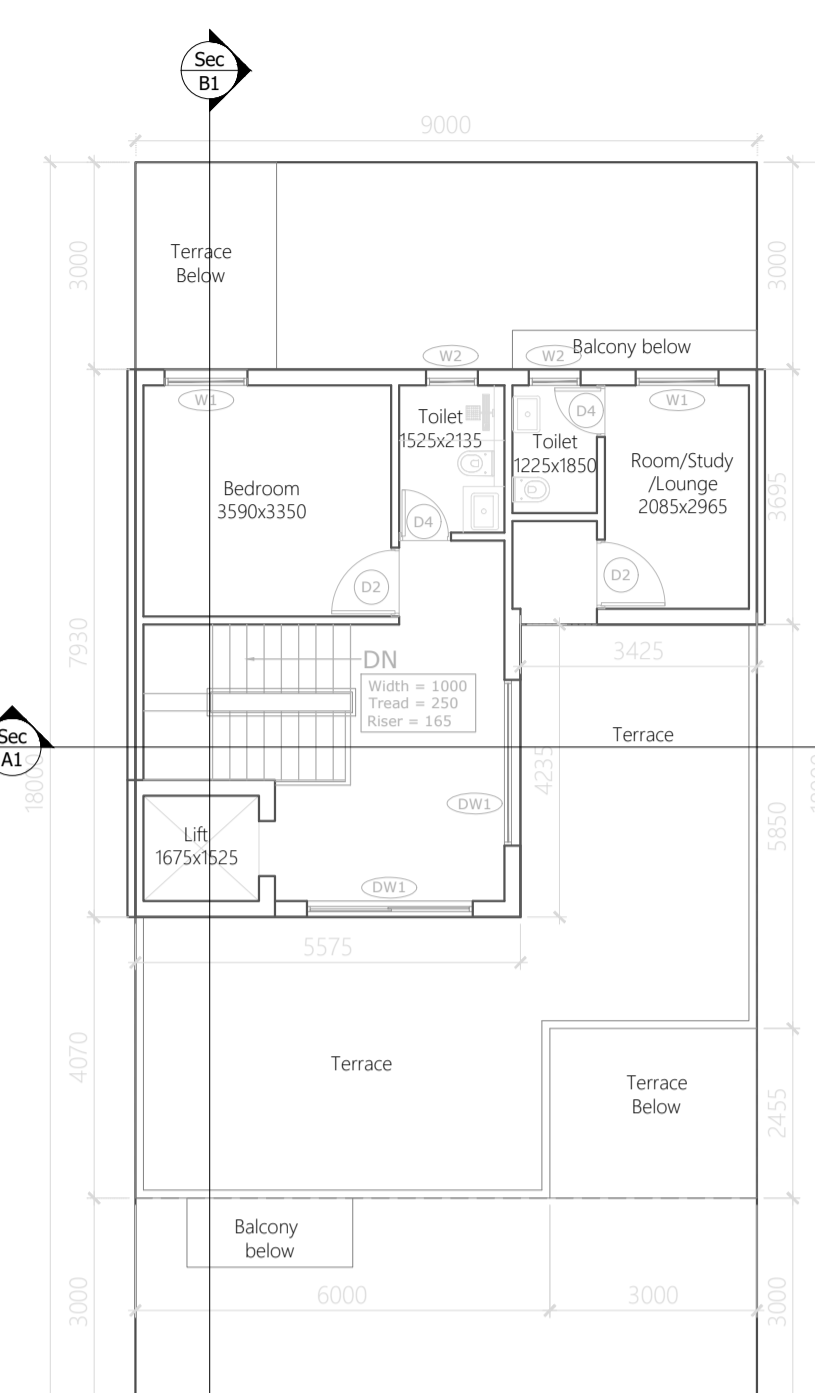

Second Floor Plan
SCALE -1:100

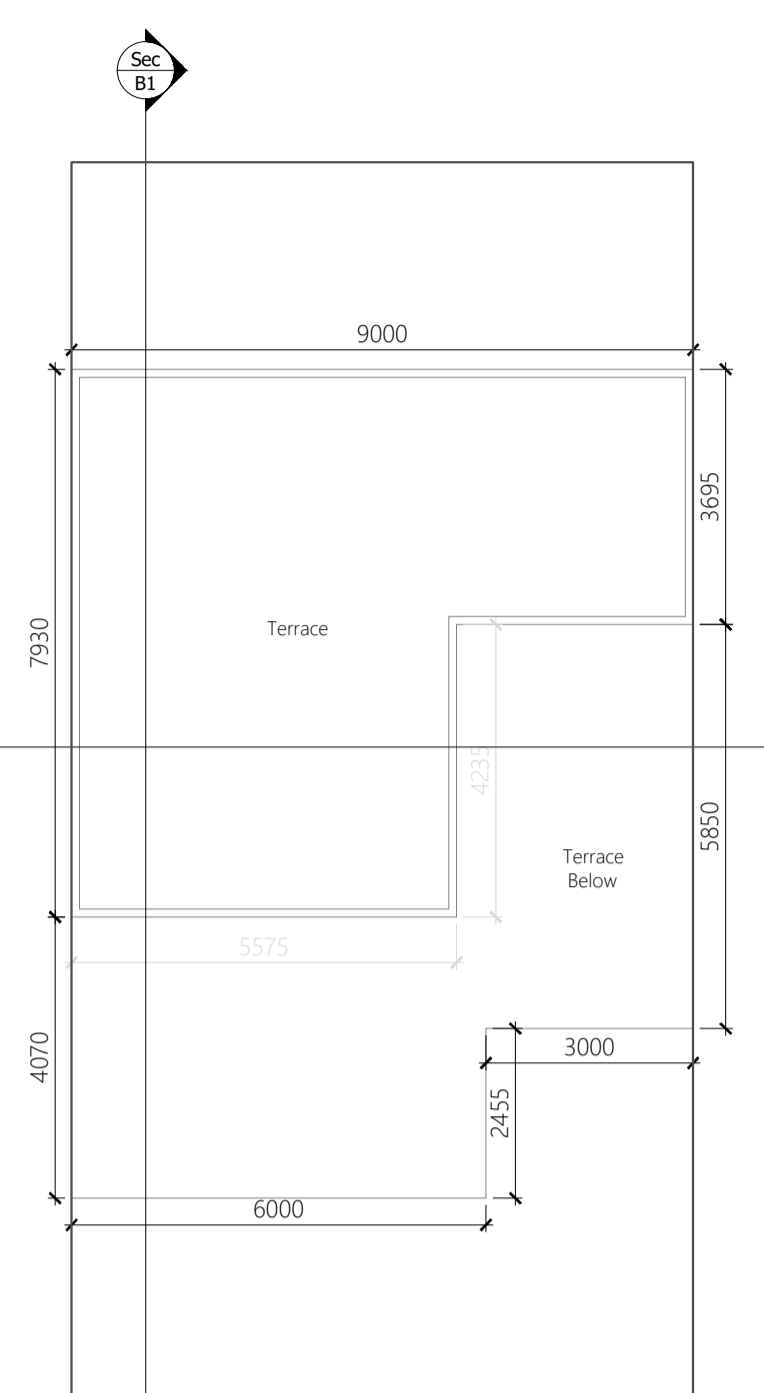

TERRACE Floor Plan
SCALE -1:100



Front Elevation
SCALE -1:100

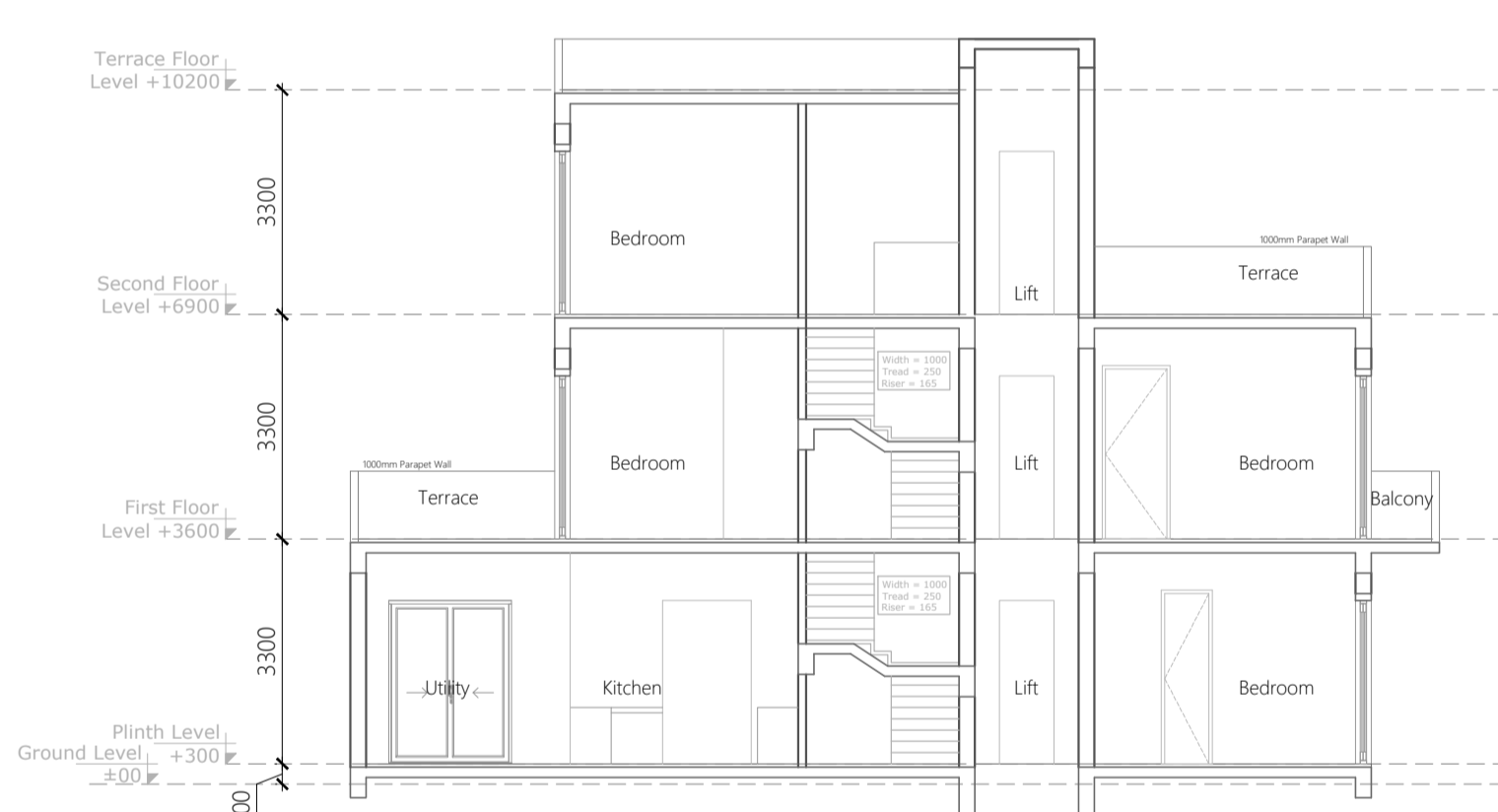

Section-B1
SCALE -1:100

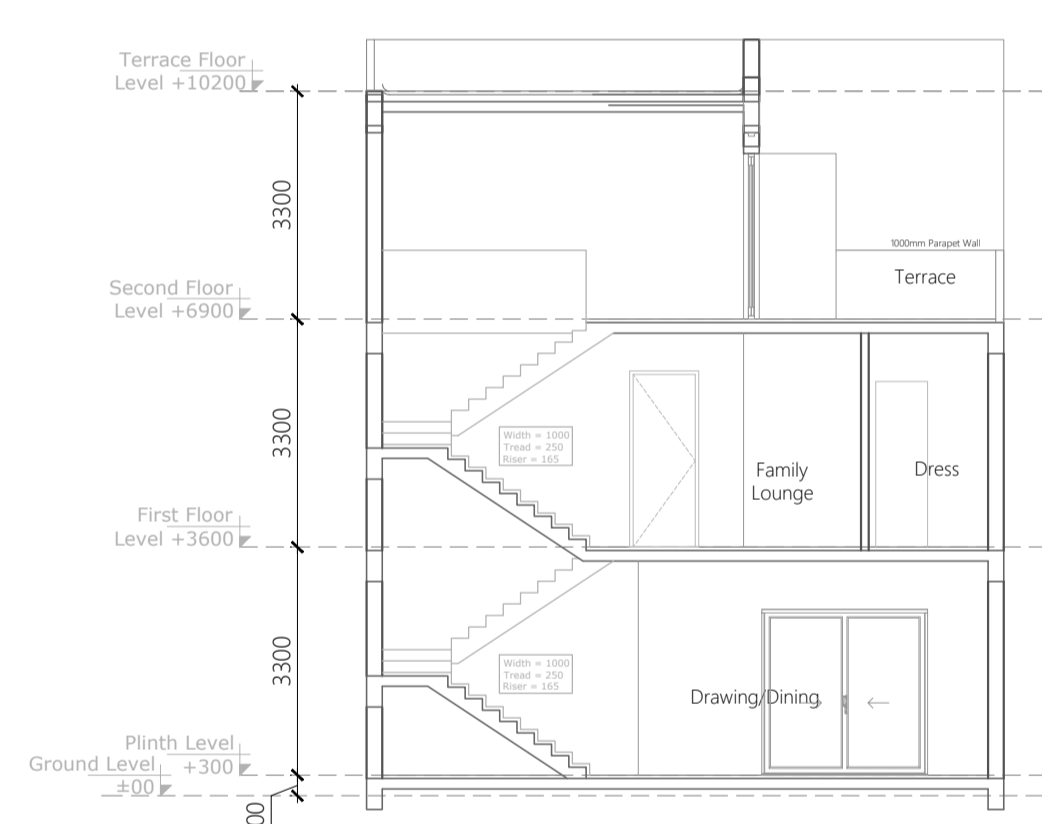

Section-A1
SCALE -1:100

Ground Floor Area Calculation

Tag	Description	Size	No.	Area Sq.mtr.	Remark
1	Rectangle	2.045 x 3.000	1	6.135	Sq.mtr.
2	Rectangle	3.000 x 3.000	1	9.000	Sq.mtr.
3	Rectangle	3.075 x 3.000	1	9.225	Sq.mtr.
Total				15.360	Sq.mtr.

First Floor Area Calculation

Tag	Description	Size	No.	Area Sq.mtr.	Remark
1	Rectangle	3.000 x 3.000	1	9.000	Sq.mtr.
2	Rectangle	3.075 x 2.400	1	7.380	Sq.mtr.
Total				16.380	Sq.mtr.

Area For Deduction

Tag	Description	Size	No.	Area Sq.mtr.	Remark
1	Rectangle	3.075 x 3.075	1	9.450	Sq.mtr.
Total				9.450	Sq.mtr.

Total F.A.R. Area at Ground Floor (G.F.)

Total F.A.R. Area	151.966	Sq.mtr.	X2
Ground Coverage	151.966	Sq.mtr.	
Total Built-up Area at Ground Floor (G.F.)	151.966	Sq.mtr.	

Second Floor Area Calculation

Tag	Description	Size	No.	Area Sq.mtr.	Remark
1	Rectangle	3.075 x 3.075	1	9.450	Sq.mtr.
2	Rectangle	3.075 x 3.000	1	9.225	Sq.mtr.
Total				18.675	Sq.mtr.

Area For Deduction

Tag	Description	Size	No.	Area Sq.mtr.	Remark
1	Rectangle	3.075 x 3.075	1	9.450	Sq.mtr.
Total				9.450	Sq.mtr.

Total F.A.R. Area at Second Floor (S.F.)

Total F.A.R. Area	54.313	Sq.mtr.	X5
Non F.A.R. Area	0.000	Sq.mtr.	
Total Built-up Area at Second Floor (S.F.)	54.313	Sq.mtr.	

DOOR - WINDOW SCHEDULE

S. No.	Type	Size	Remark
1	DW1	2400x2400	Door/ Window
2	DW2	1800x2400	Door/ Window
3	DW2	1370x2400	Door/ Window
4	D1	1500x2400	Door
5	D2	1000x2400	Door
6	D3	900x2400	Door
7	D4	750x2400	Door
8	W1	1200x1500	Window
9	W2	750x1200	Window

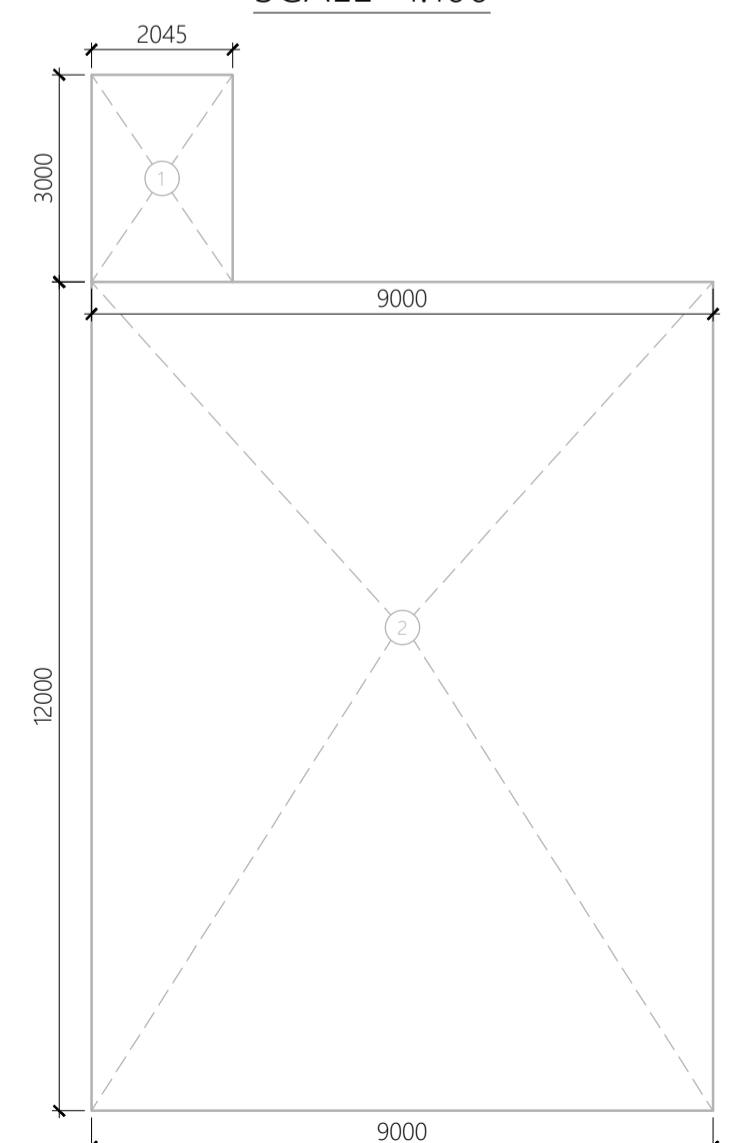

Area Envelope Plan of
Ground Floor

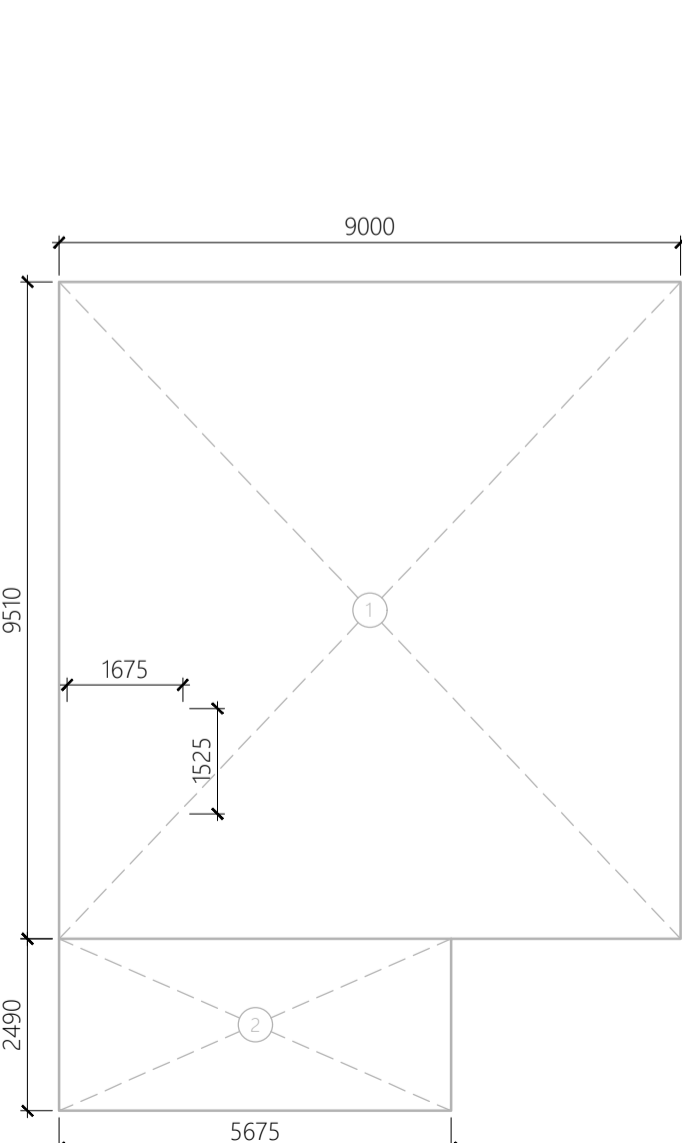

Area Envelope Plan of
First Floor

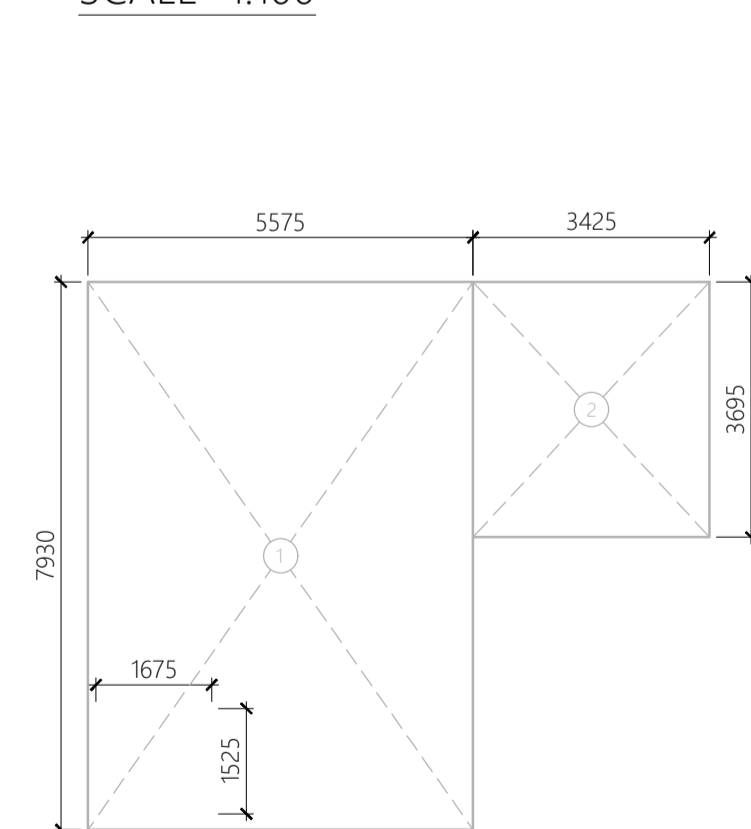

Area Envelope Plan of
Second Floor



KEY PLAN
SCALE -1:100



Lucknow Development Authority

FOR OFFICE :-

PROJECT TITLE-

**PROPOSED RESIDENTIAL
SUBMISSION DRAWING FOR THE
VILLA ON PLOT NO - 295 P1
POCKET - L TYPE- E OMAXE HI-TECH
CITY AT LUCKNOW**

AREA STATEMENT

S.NO.	PARTICULARS	SQ.MTR.
1.	PLOT AREA	162.0
2.	PERMISSIBLE GROUND FLOOR COVERAGE (65%)	105.300
3.	PROPOSED GROUND COVERAGE(64.19%)	104.00
4.	PROPOSED FIRST FLOOR AREA	97.166
5.	PROPOSED SECOND FLOOR AREA	56.865
6.	PROPOSED TERRACE FLOOR AREA	0.0
7.	PROPOSED PORCH AREA	10.08
8.	PERMISSIBLE F. A. R. (2.0)	324.00
9.	PROPOSED F. A. R. = [G.F. + F.F.+S.F](1.592)	258.031
10.	TOTAL COVERED AREA (3+4+5+6+7)	268.11

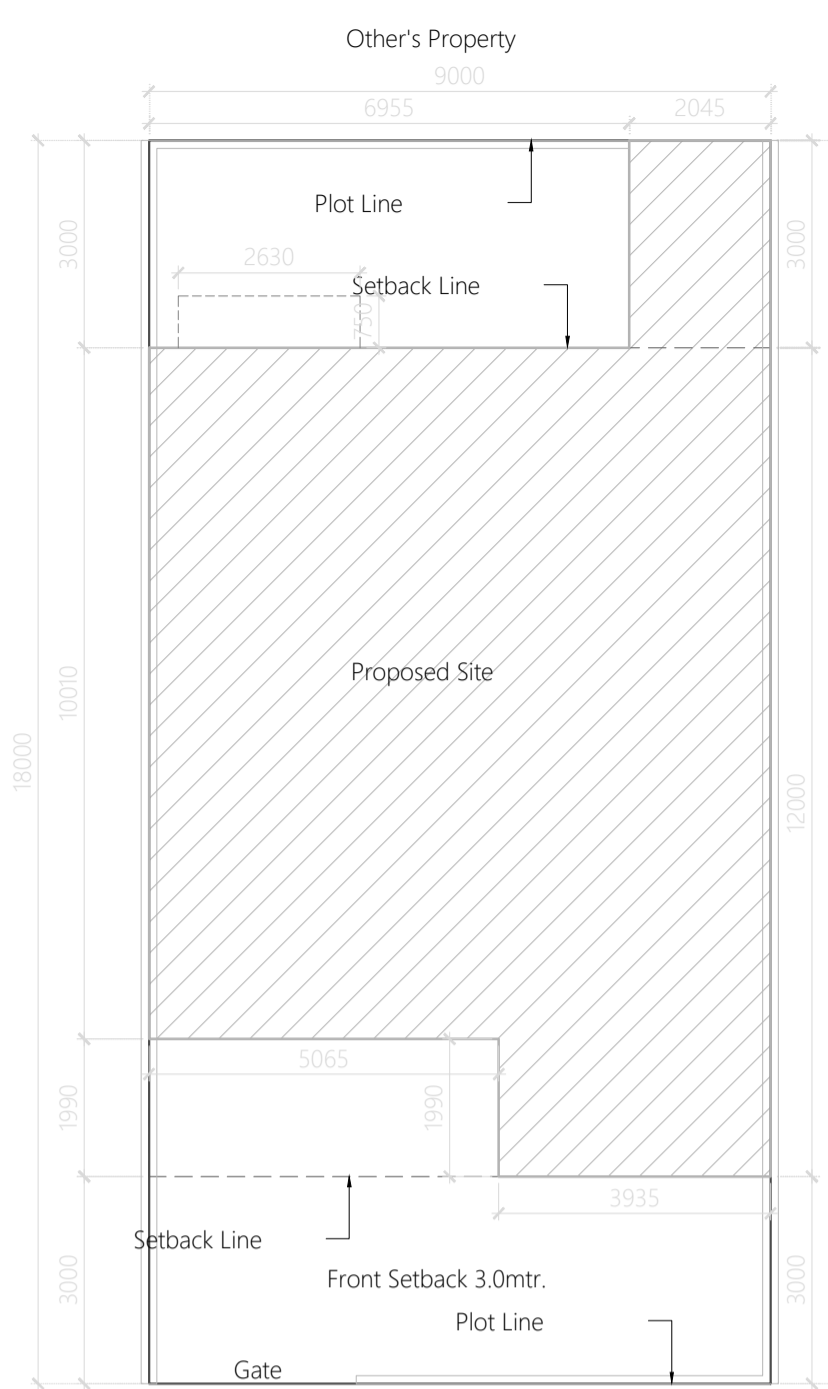

Site Plan
SCALE -1:100

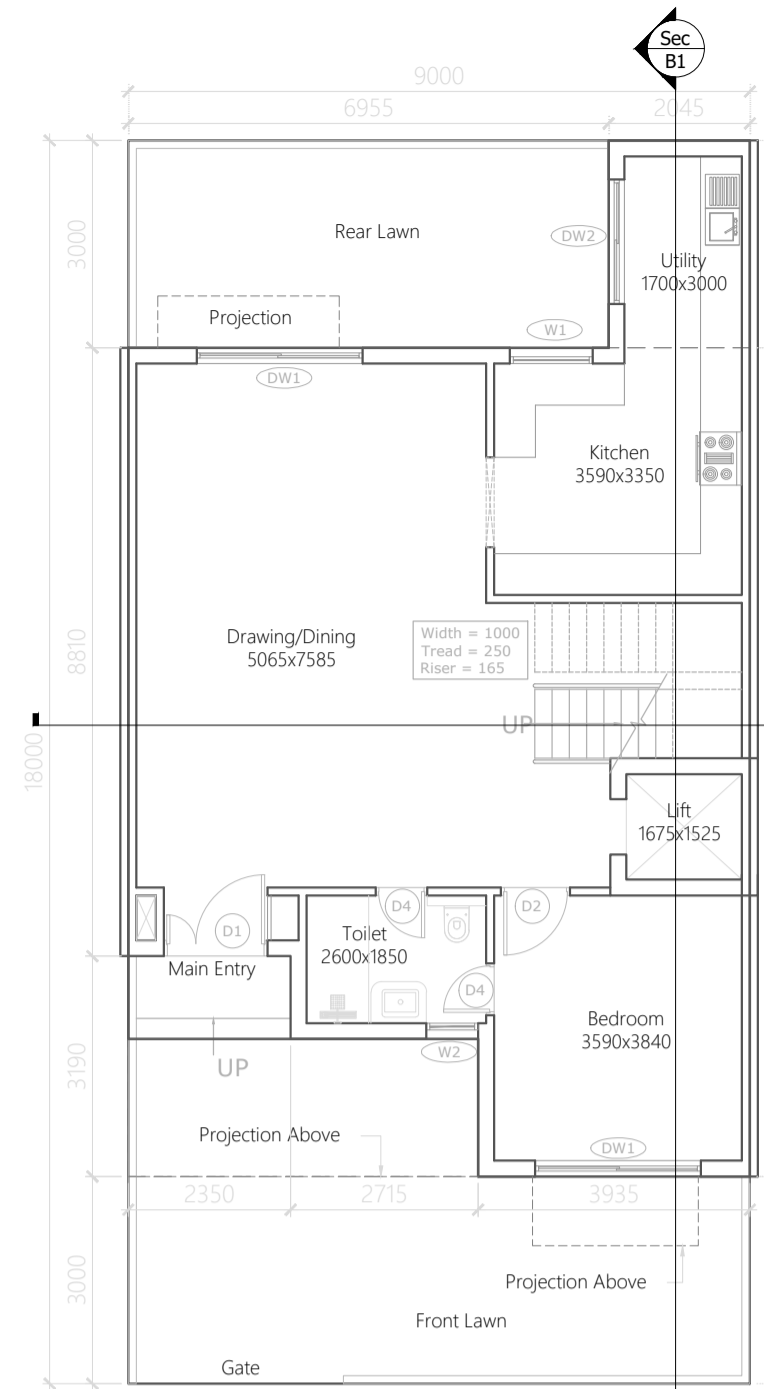

Ground Floor Plan
SCALE -1:100

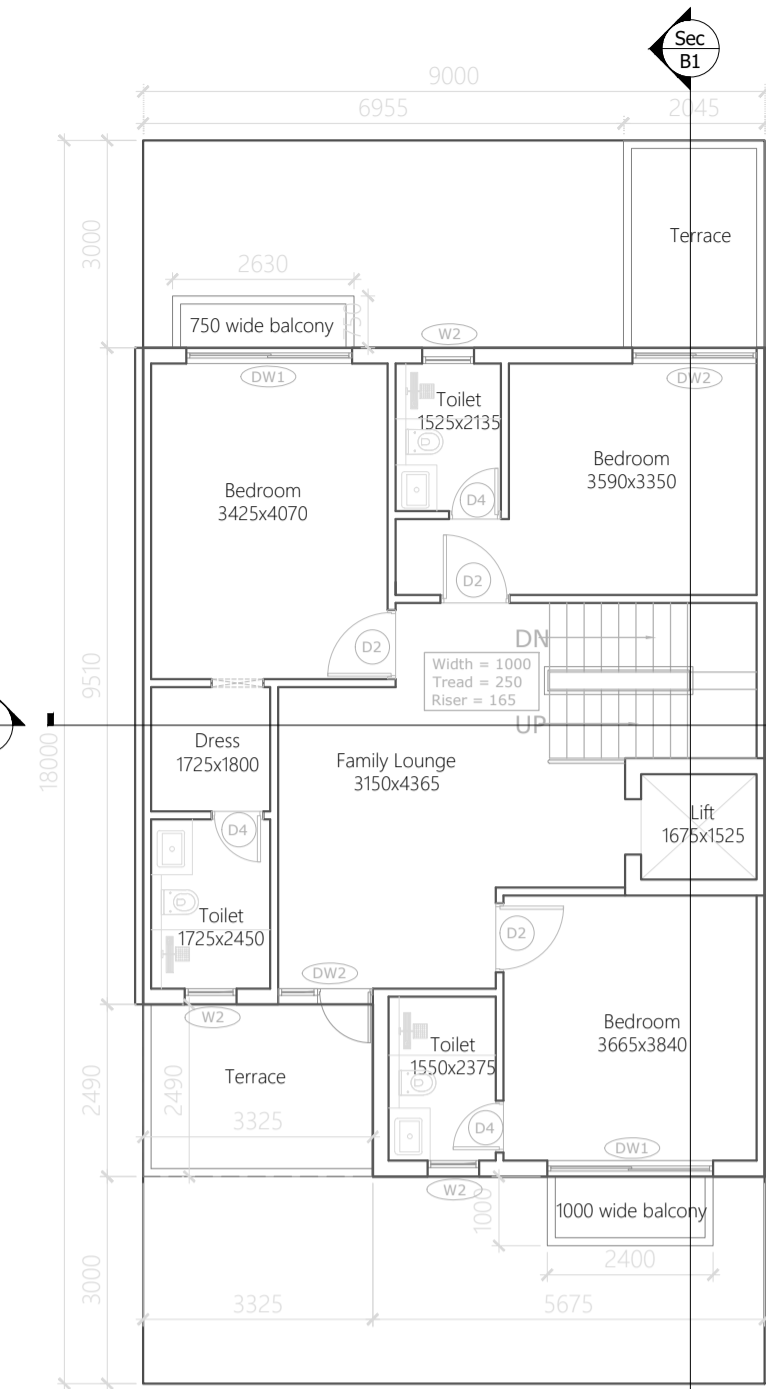

First Floor Plan
SCALE -1:100

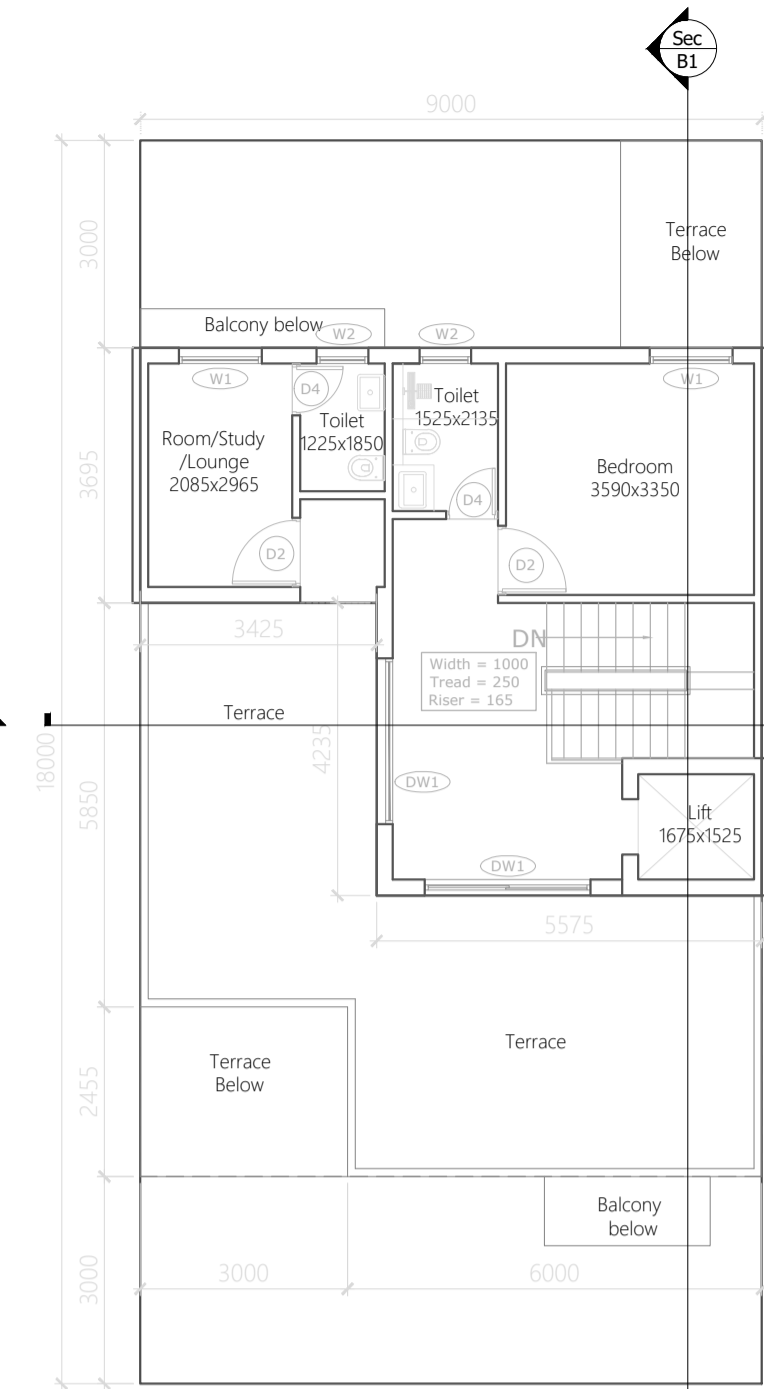

Second Floor Plan
SCALE -1:100

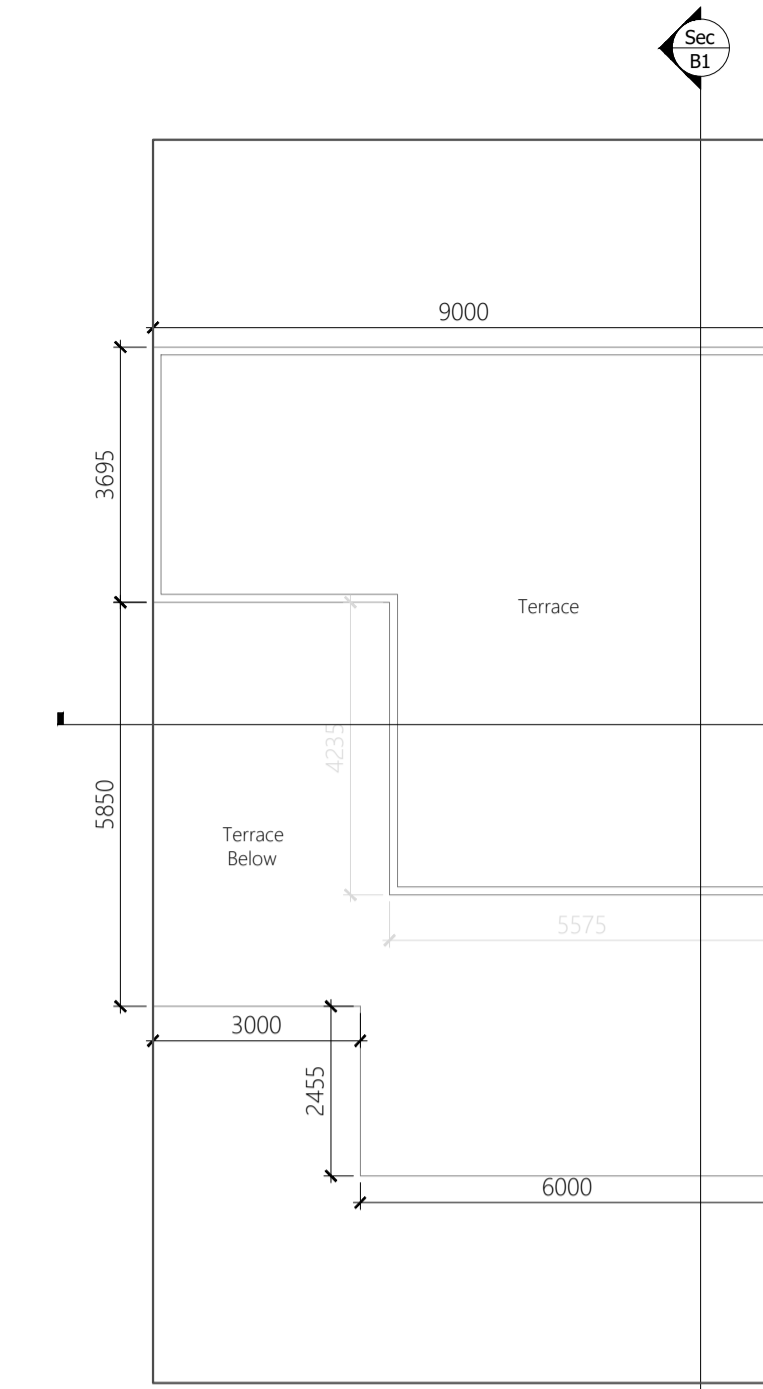

TERRACE Floor Plan
SCALE -1:100



Front Elevation
SCALE -1:100



Section-B1
SCALE -1:100

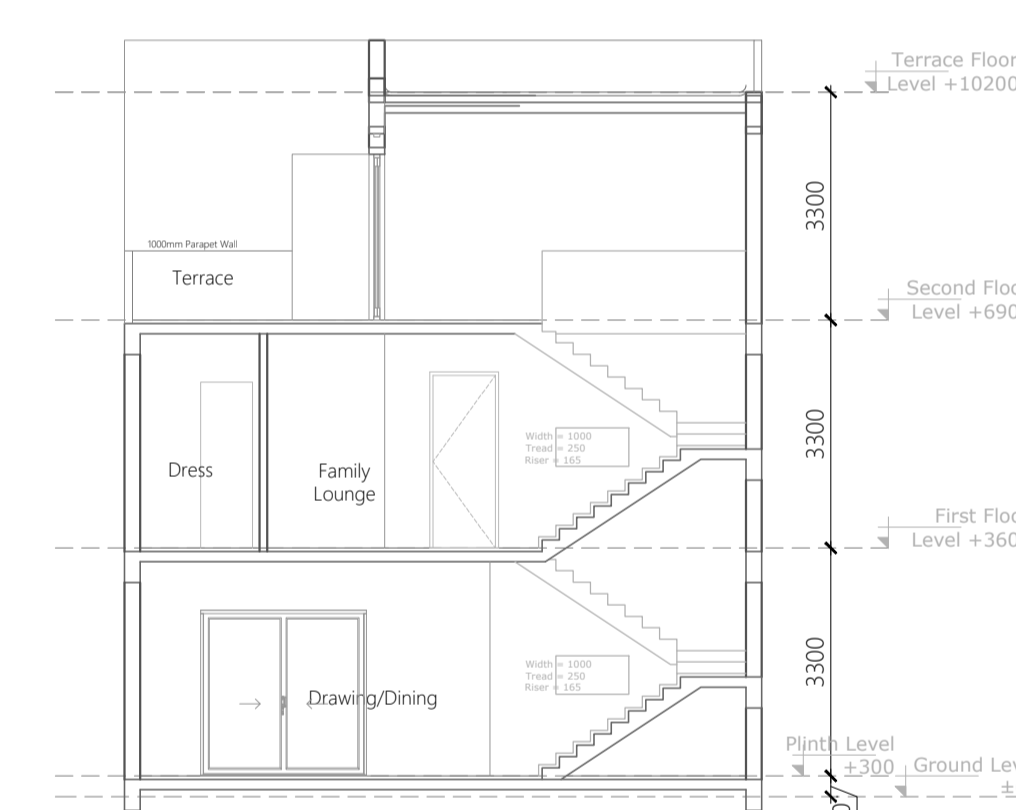

Section-A1
SCALE -1:100

Ground Floor Area Calculation				
Tag	Description	Size	Nos.	Area Sq.mtr.
1	Rectangle	2.045	3.000	6.135 Sq.mtr
2	Rectangle	9.000	10.100	90.900 Sq.mtr
3	Rectangle	3.935	1.990	7.831 Sq.mtr
Total				104.866 Sq.mtr

First Floor Area Calculation				
Tag	Description	Size	Nos.	Area Sq.mtr.
1	Rectangle	9.000	9.510	85.590 Sq.mtr
2	Rectangle	5.675	2.490	14.131 Sq.mtr
Total				99.721 Sq.mtr

Second Floor Area Calculation				
Tag	Description	Size	Nos.	Area Sq.mtr.
1	Rectangle	5.575	7.930	44.210 Sq.mtr
2	Rectangle	3.425	3.695	12.655 Sq.mtr
Total				56.865 Sq.mtr

NOTE :- ALL DIMENSIONS ARE IN MM

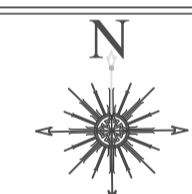

PROJECT ADDRESS:-

VILLA (9.0MX18.0M) IN
OMAXE HITECH CITY , LUCKNOW U.P.

OWNER NAME:-

OMAXE GARV BUILDTECH PVT LIMITED

This drawing is a "COPYRIGHT" contents of this drawing or part thereof may not be used or reproduced without the permission of the Architect

OWNER SIGNATURE



ARCHITECT SIGNATURE

Ar. Sachin Yadav
CA/2021/140419

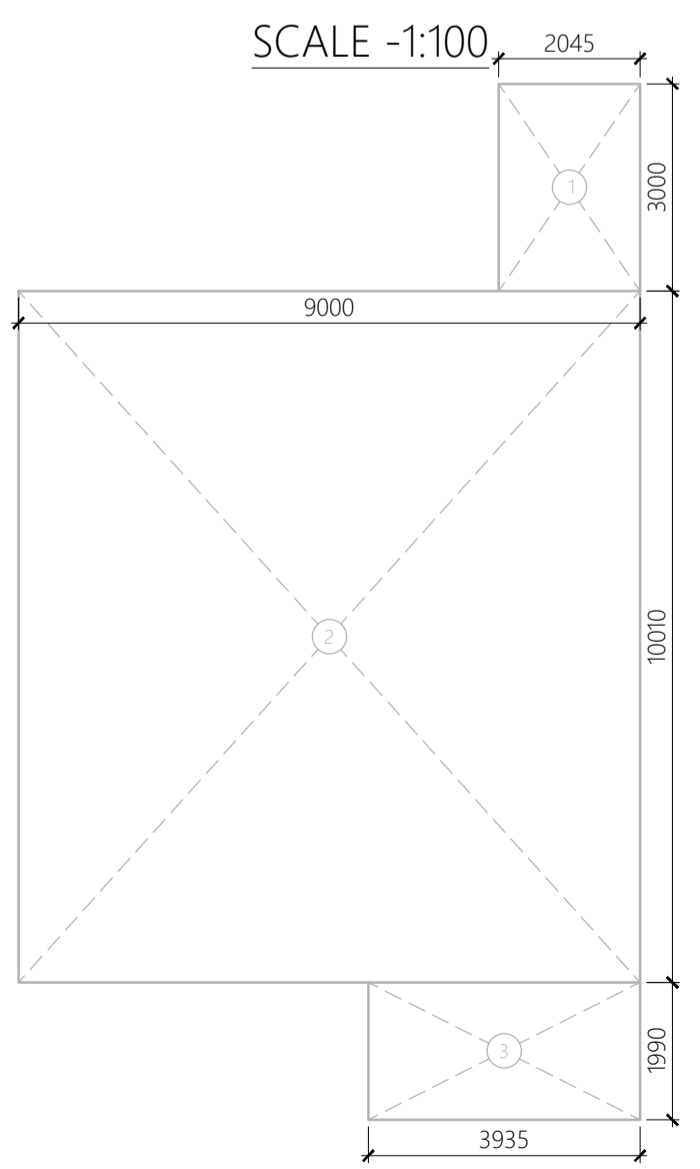

Area Envelope Plan of
Ground Floor

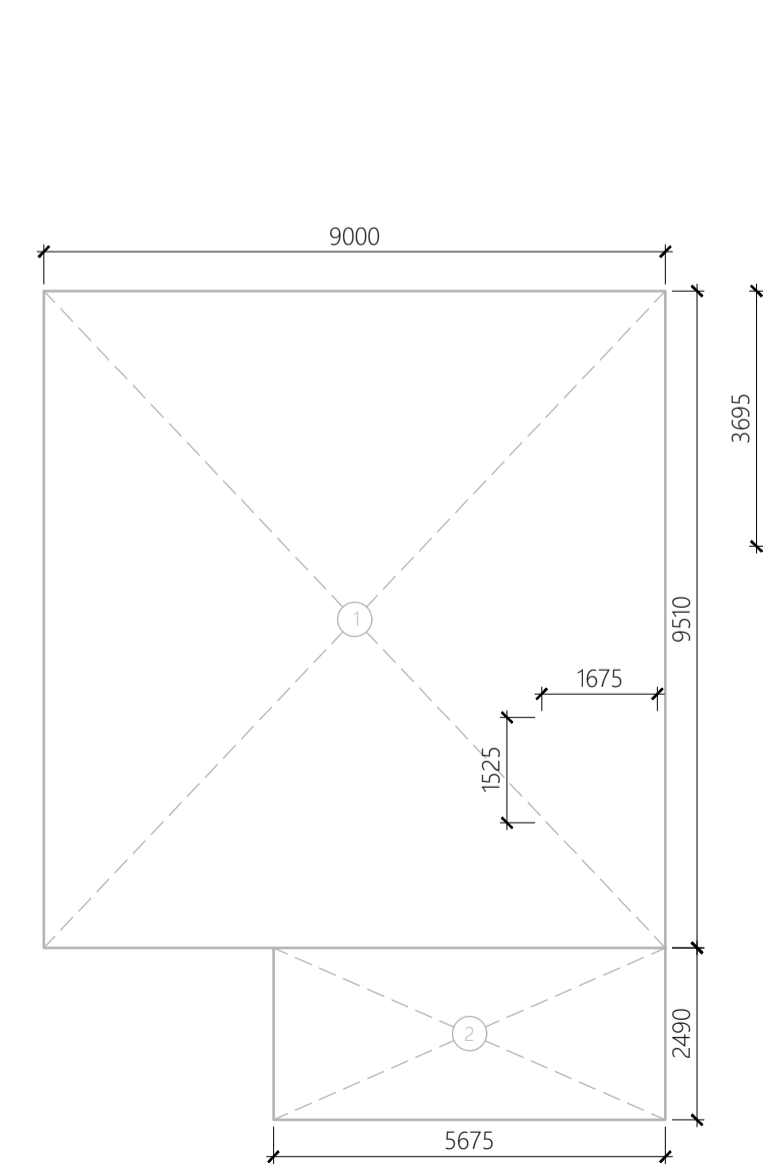

Area Envelope Plan of
First Floor

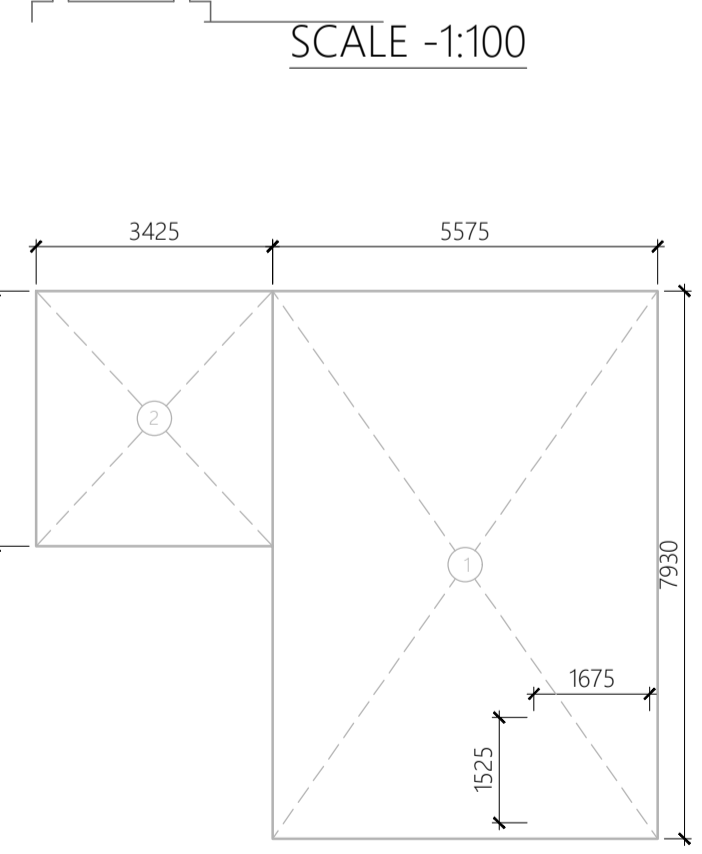

Area Envelope Plan of
Second Floor

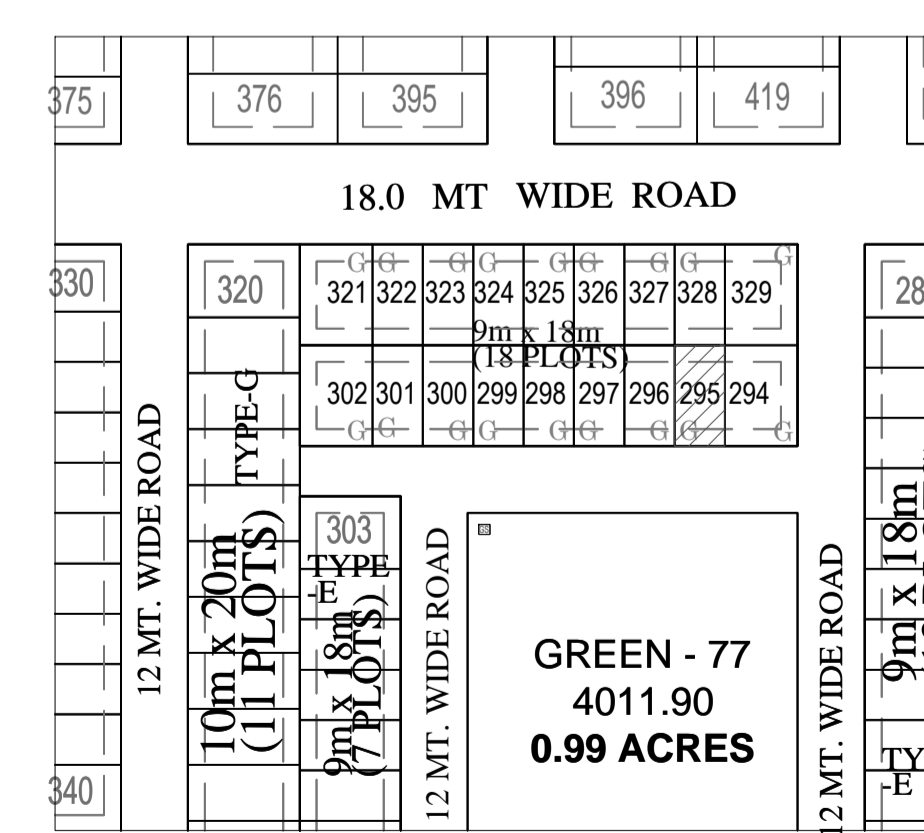

KEY PLAN
SCALE -1:100

DOOR - WINDOW SCHEDULE			
S. No.	Type	Size	Remark
1	DW1	2400x2400	Door/ Window
2	DW2	1800x2400	Door/ Window
3	DW2	1370x2400	Door/ Window
4	D1	1500x2400	Door
5	D2	1000x2400	Door
6	D3	900x2400	Door
7	D4	750x2400	Door
8	W1	1200x1500	Window
9	W2	750x1200	Window



FOR OFFICE :-

PROJECT TITLE-

**PROPOSED RESIDENTIAL
SUBMISSION DRAWING FOR THE
VILLA ON PLOT NO - 296 P1
POCKET - L TYPE- E OMAXE
HI-TECH CITY AT LUCKNOW**

AREA STATEMENT

S.NO.	PARTICULARS	SQ.MTR.
1.	PLOT AREA	162.0
2.	PERMISSIBLE GROUND FLOOR COVERAGE (65%)	105.300
3.	PROPOSED GROUND COVERAGE(64.19%)	104.00
4.	PROPOSED FIRST FLOOR AREA	97.166
5.	PROPOSED SECOND FLOOR AREA	56.865
6.	PROPOSED TERRACE FLOOR AREA	0.0
7.	PROPOSED PORCH AREA	10.08
8.	PERMISSIBLE F. A. R. (2.0)	324.00
9.	PROPOSED F. A. R. = [G.F. + F.F.+S.F.](1.592)	258.031
10.	TOTAL COVERED AREA (3+4+5+6+7)	268.11

NOTE :- ALL DIMENSIONS ARE IN MM

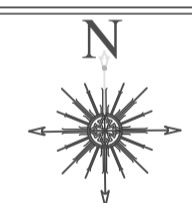

PROJECT ADDRESS:-

**VILLA (9.0MX18.0M) IN
OMAXE HITECH CITY , LUCKNOW U.P.**

OWNER NAME:-

OMAXE GARV BUILDTech PVT LIMITED

This drawing is a "COPYRIGHT" contents of this drawing or part thereof may not be used or reproduced without the permission of the Architect

OWNER SIGNATURE



ARCHITECT SIGNATURE

Sachin Yadav
Ar. Sachin Yadav
CA/2021/140419

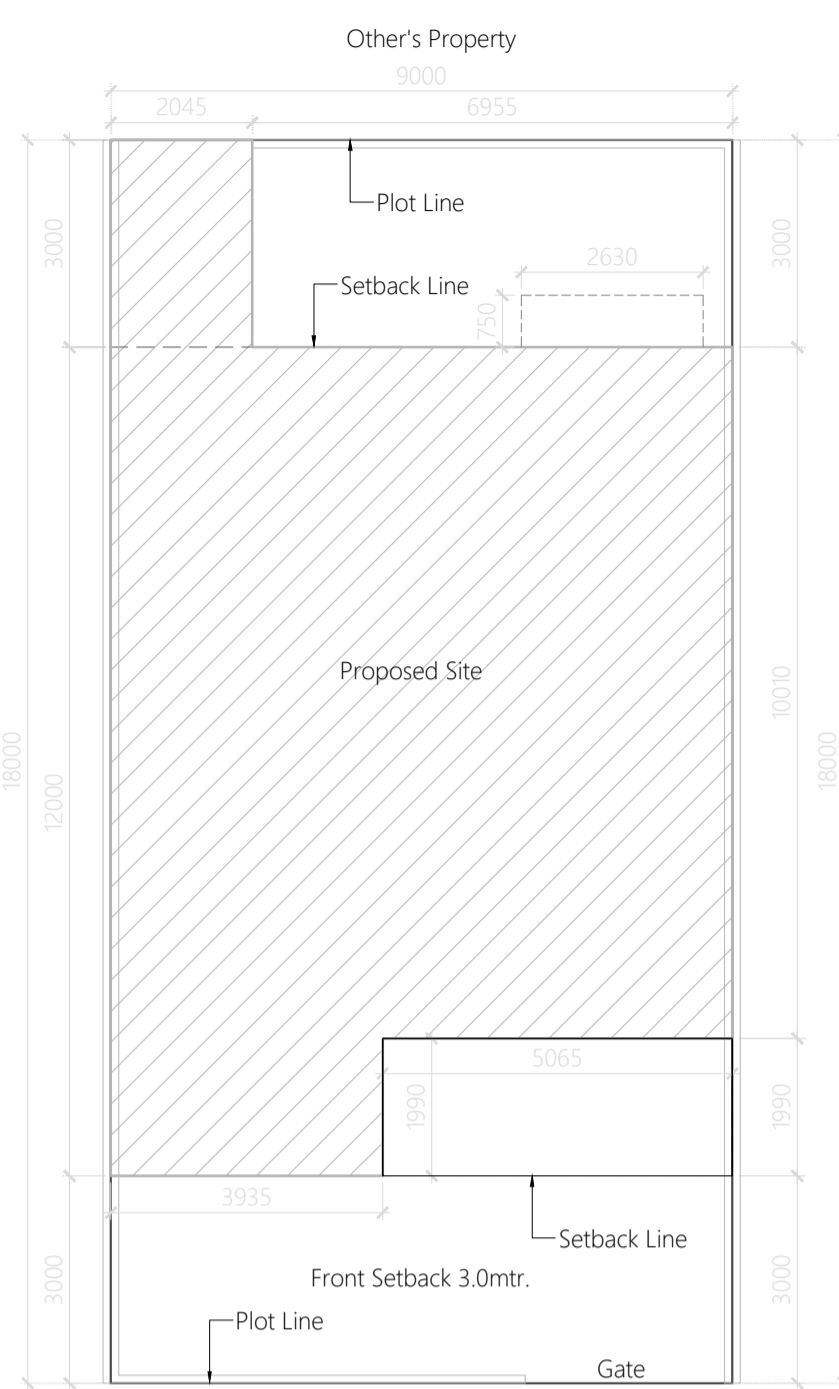

Site Plan
SCALE -1:100

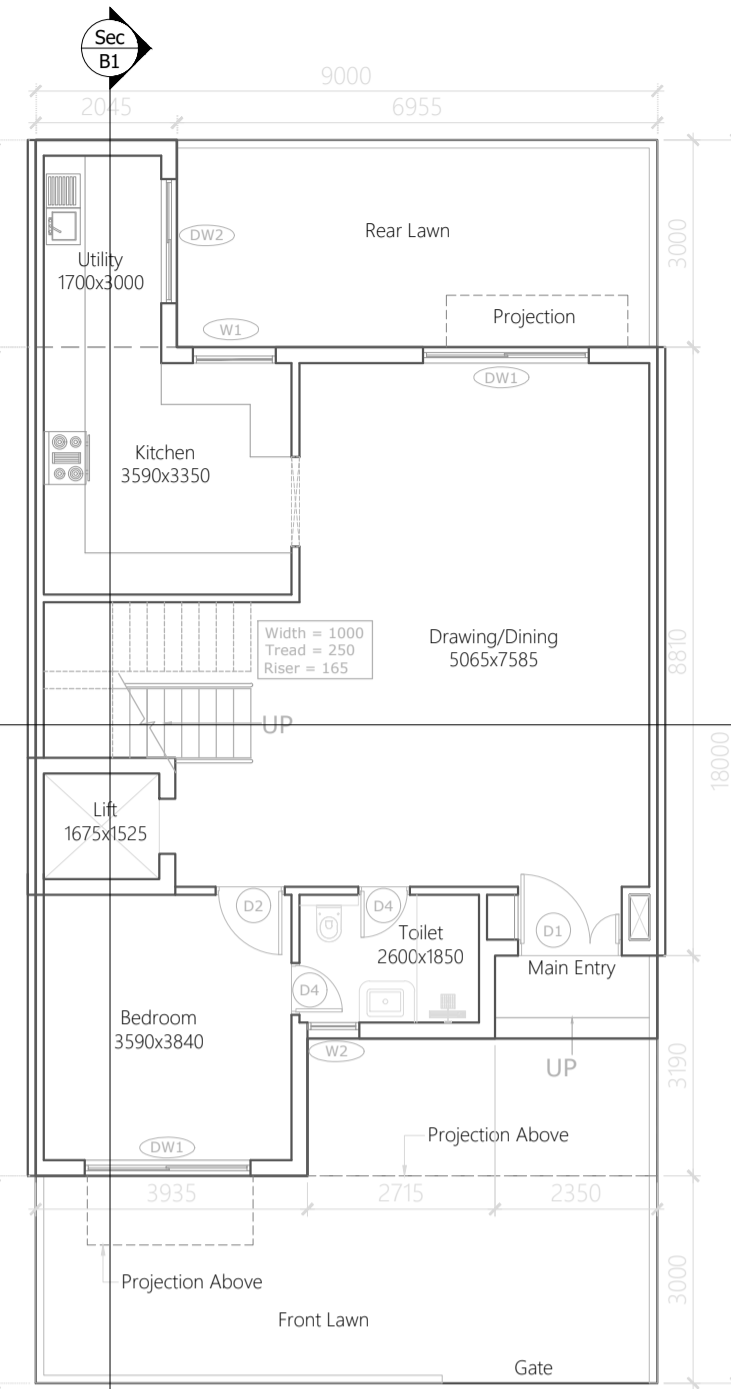

Ground Floor Plan
SCALE -1:100

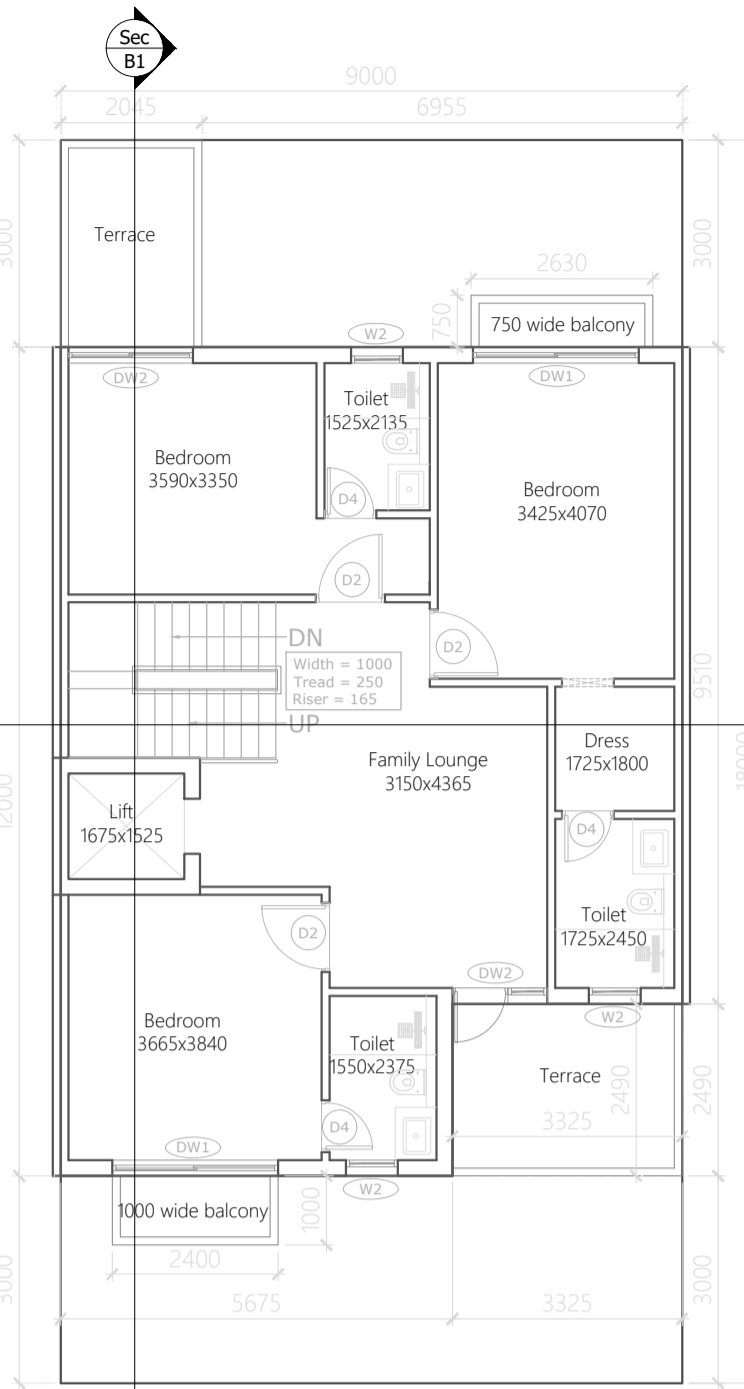

First Floor Plan
SCALE -1:100

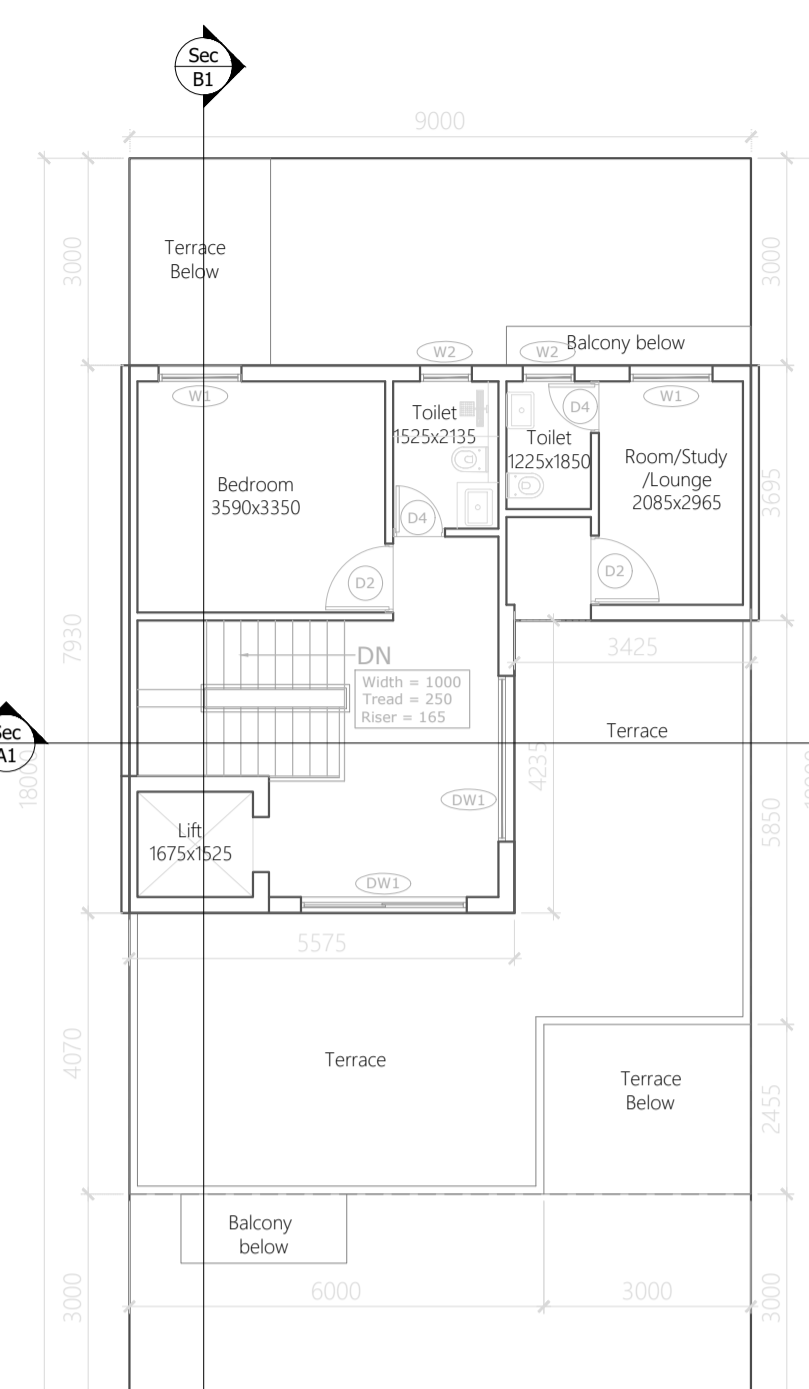

Second Floor Plan
SCALE -1:100

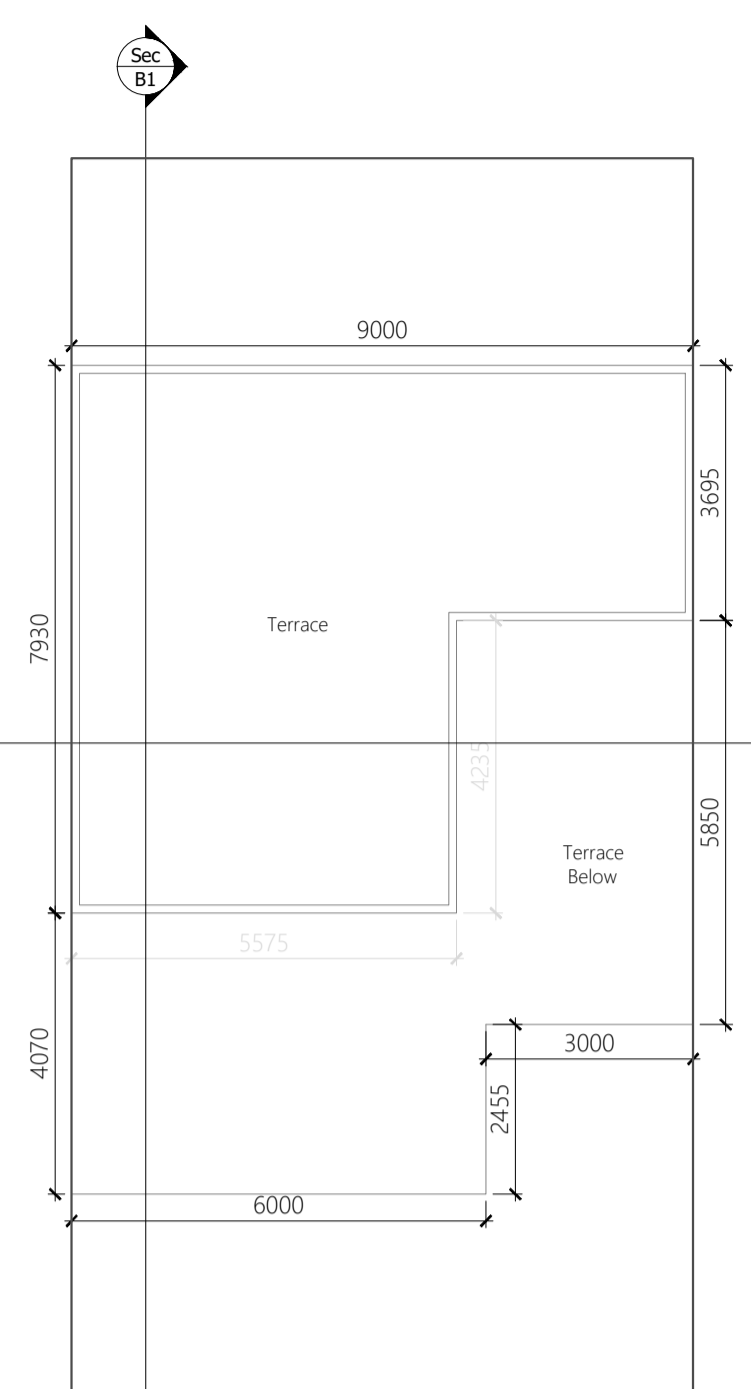

TERRACE Floor Plan
SCALE -1:100



Front Elevation
SCALE -1:100



Section-B1
SCALE -1:100

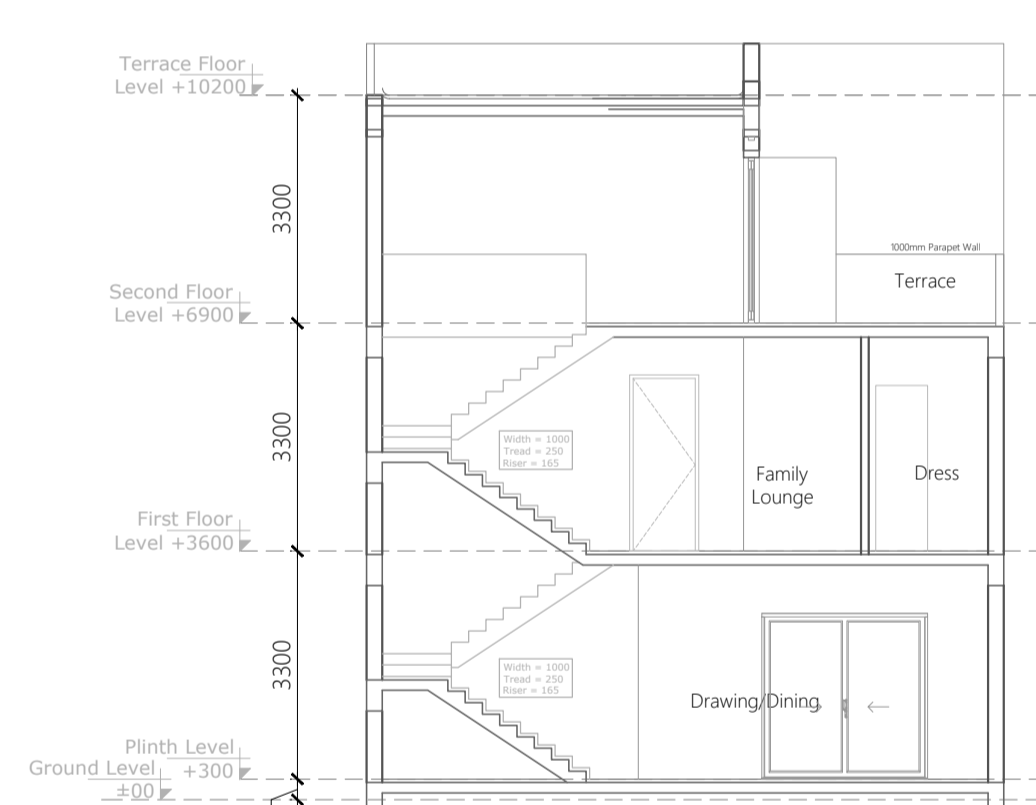

Section-A1
SCALE -1:100

Ground Floor Area Calculation

Tag	Description	Size	No.	Area Sq.mtr.	Remark
1	Rectangle	2.045 x 3.000	1	6.135	Sq.mtr.
2	Rectangle	3.000 x 3.000	1	9.000	Sq.mtr.
3	Rectangle	3.025 x 3.000	1	9.075	Sq.mtr.
Total				24.210	Sq.mtr.

First Floor Area Calculation

Tag	Description	Size	No.	Area Sq.mtr.	Remark
1	Rectangle	3.000 x 3.000	1	9.000	Sq.mtr.
2	Rectangle	3.025 x 2.400	1	7.260	Sq.mtr.
Total				16.260	Sq.mtr.

Area For Deduction

Tag	Description	Size	No.	Area Sq.mtr.	Remark
1	Rectangle	3.025 x 3.025	1	9.151	Sq.mtr.
Total				9.151	Sq.mtr.

Total F.A.R. Area at Ground Floor (G.F.)

Total F.A.R. Area at Ground Floor (G.F.)	131.966	Sq.mtr.	X2
Ground Coverage	131.966	Sq.mtr.	
Total Built-up Area at Ground Floor (G.F.)	131.966	Sq.mtr.	

Second Floor Area Calculation

Tag	Description	Size	No.	Area Sq.mtr.	Remark
1	Rectangle	3.025 x 3.000	1	9.075	Sq.mtr.
2	Rectangle	3.025 x 3.000	1	9.075	Sq.mtr.
Total				18.150	Sq.mtr.

Area For Deduction

Tag	Description	Size	No.	Area Sq.mtr.	Remark
1	Rectangle	3.025 x 3.025	1	9.151	Sq.mtr.
Total				9.151	Sq.mtr.

Total F.A.R. Area at Second Floor (S.F.)

Total F.A.R. Area at Second Floor (S.F.)	54.313	Sq.mtr.	X2
Total F.A.R. Area	186.279	Sq.mtr.	
Total Built-up Area at Second Floor (S.F.)	54.313	Sq.mtr.	

DOOR - WINDOW SCHEDULE

S. No.	Type	Size	Remark
1	DW1	2400x2400	Door/ Window
2	DW2	1800x2400	Door/ Window
3	DW2	1370x2400	Door/ Window
4	D1	1500x2400	Door
5	D2	1000x2400	Door
6	D3	900x2400	Door
7	D4	750x2400	Door
8	W1	1200x1500	Window
9	W2	750x1200	Window

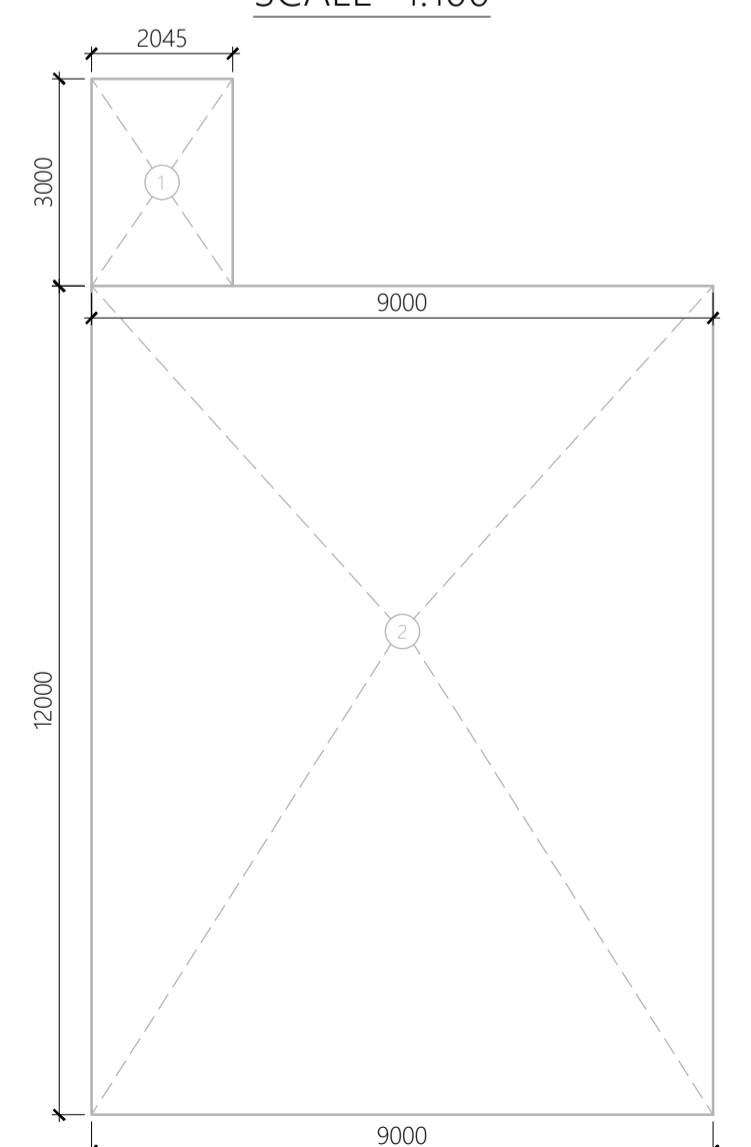

Area Envelope Plan of
Ground Floor

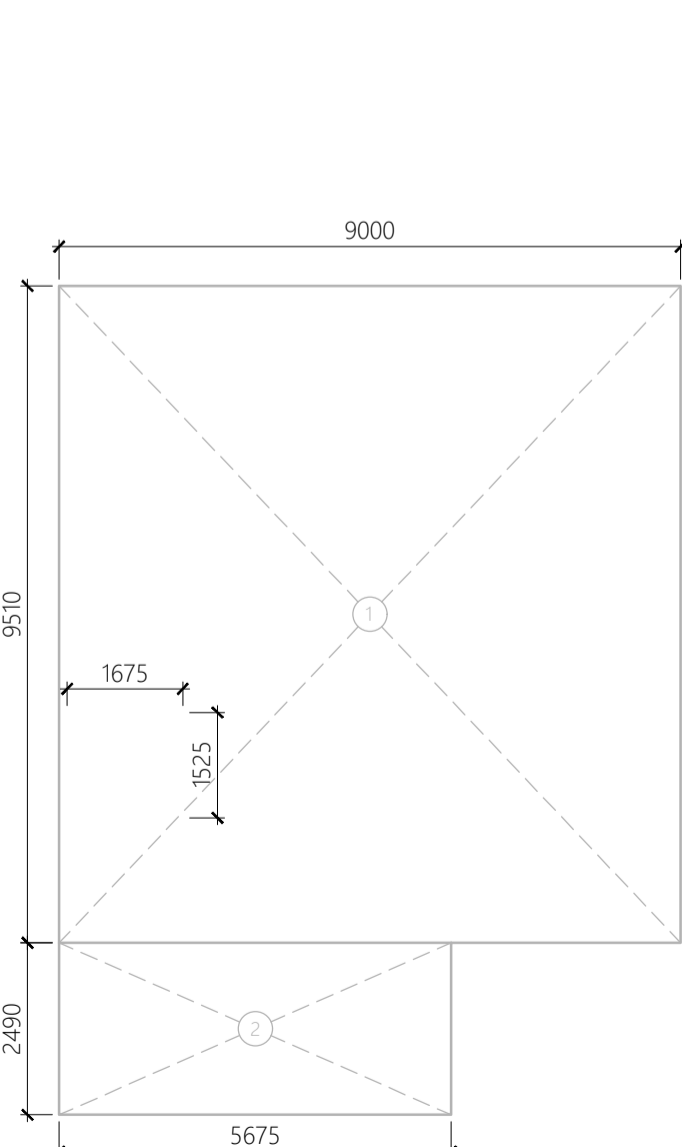

Area Envelope Plan of
First Floor

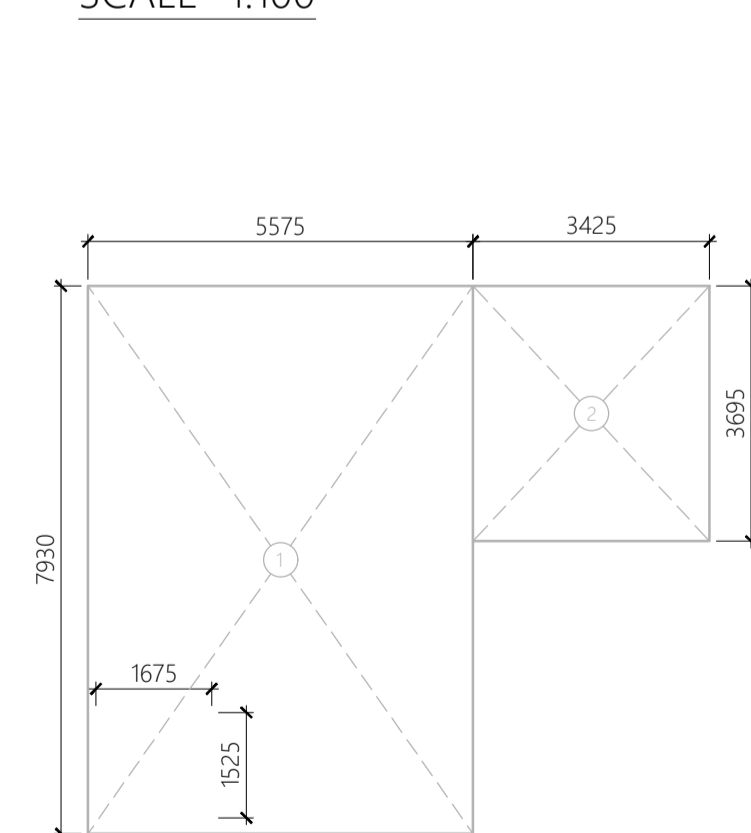

Area Envelope Plan of
Second Floor

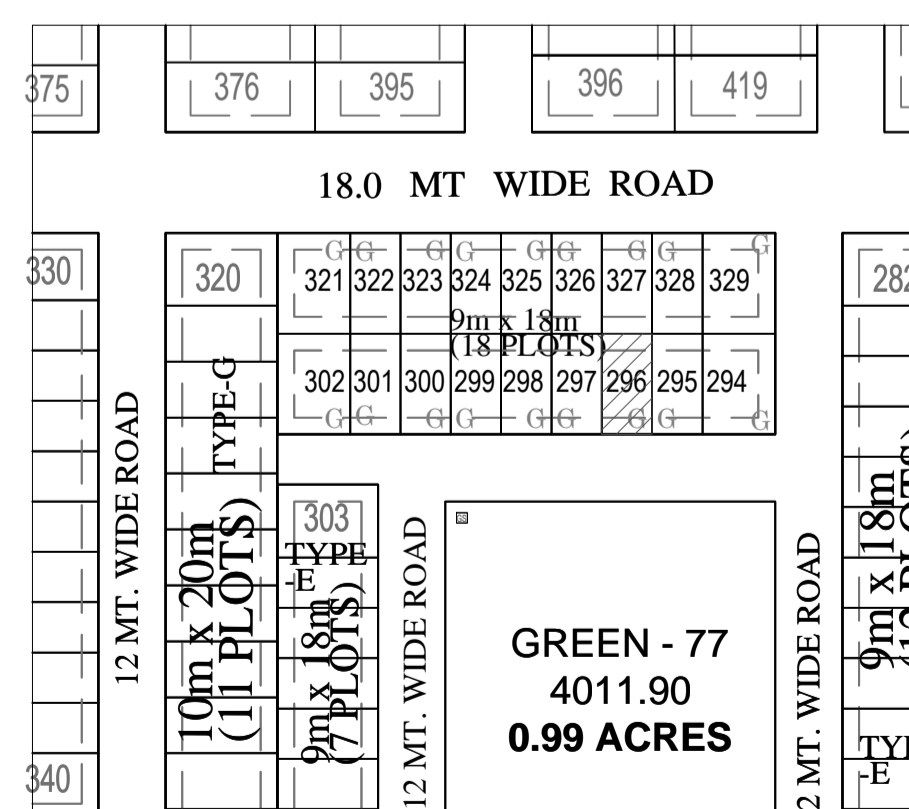

KEY PLAN
SCALE -1:100



Lucknow Development Authority

FOR OFFICE :-

PROJECT TITLE-

**PROPOSED RESIDENTIAL
SUBMISSION DRAWING FOR THE
VILLA ON PLOT NO - 297 P1
POCKET - L TYPE- E OMAXE HI-TECH
CITY AT LUCKNOW**

AREA STATEMENT

S.NO.	PARTICULARS	SQ.MTR.
1.	PLOT AREA	162.0
2.	PERMISSIBLE GROUND FLOOR COVERAGE (65%)	105.300
3.	PROPOSED GROUND COVERAGE(64.19%)	104.00
4.	PROPOSED FIRST FLOOR AREA	97.166
5.	PROPOSED SECOND FLOOR AREA	56.865
6.	PROPOSED TERRACE FLOOR AREA	0.0
7.	PROPOSED PORCH AREA	10.08
8.	PERMISSIBLE F. A. R. (2.0)	324.00
9.	PROPOSED F. A. R. = [G.F. + F.F.+S.F](1.592)	258.031
10.	TOTAL COVERED AREA (3+4+5+6+7)	268.11

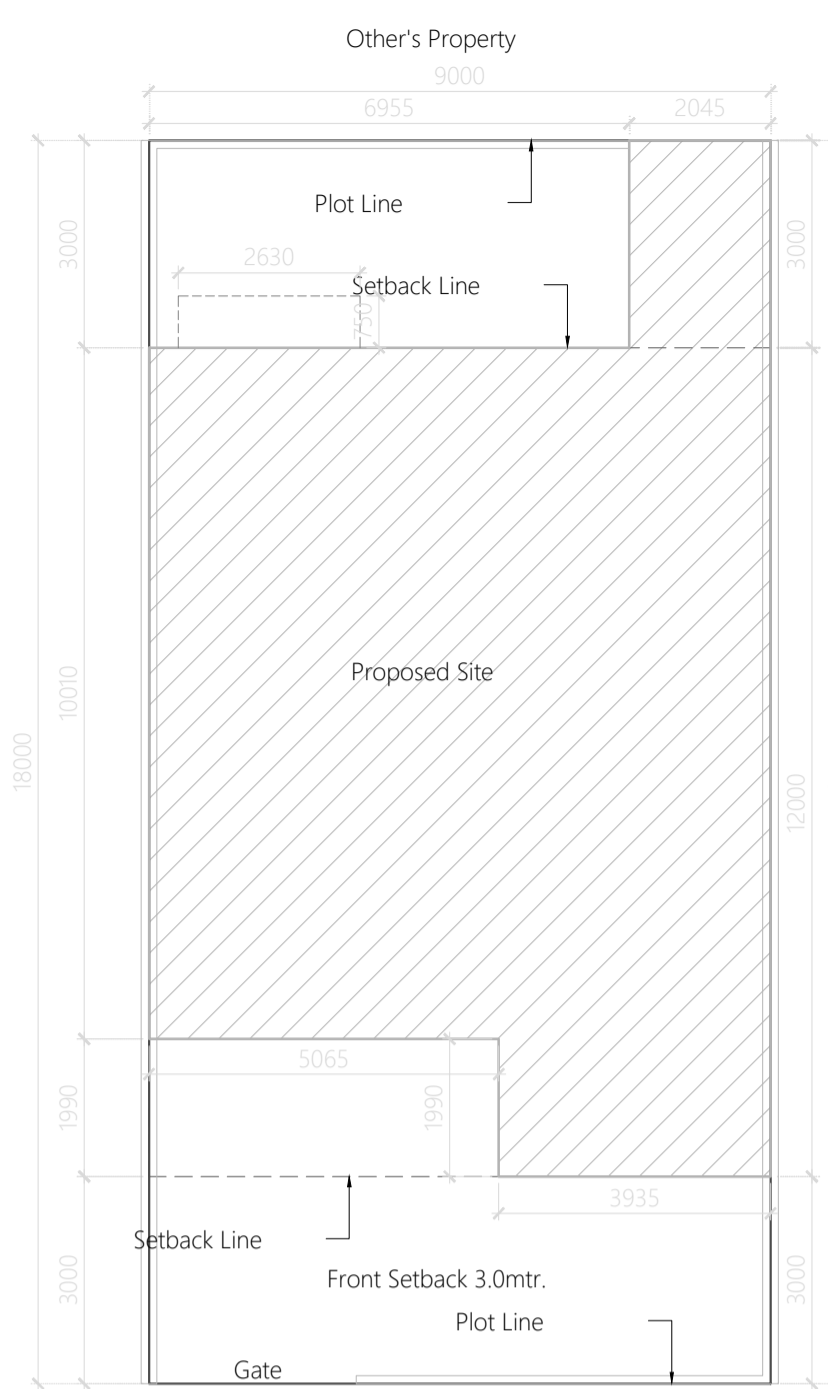

Site Plan
SCALE -1:100

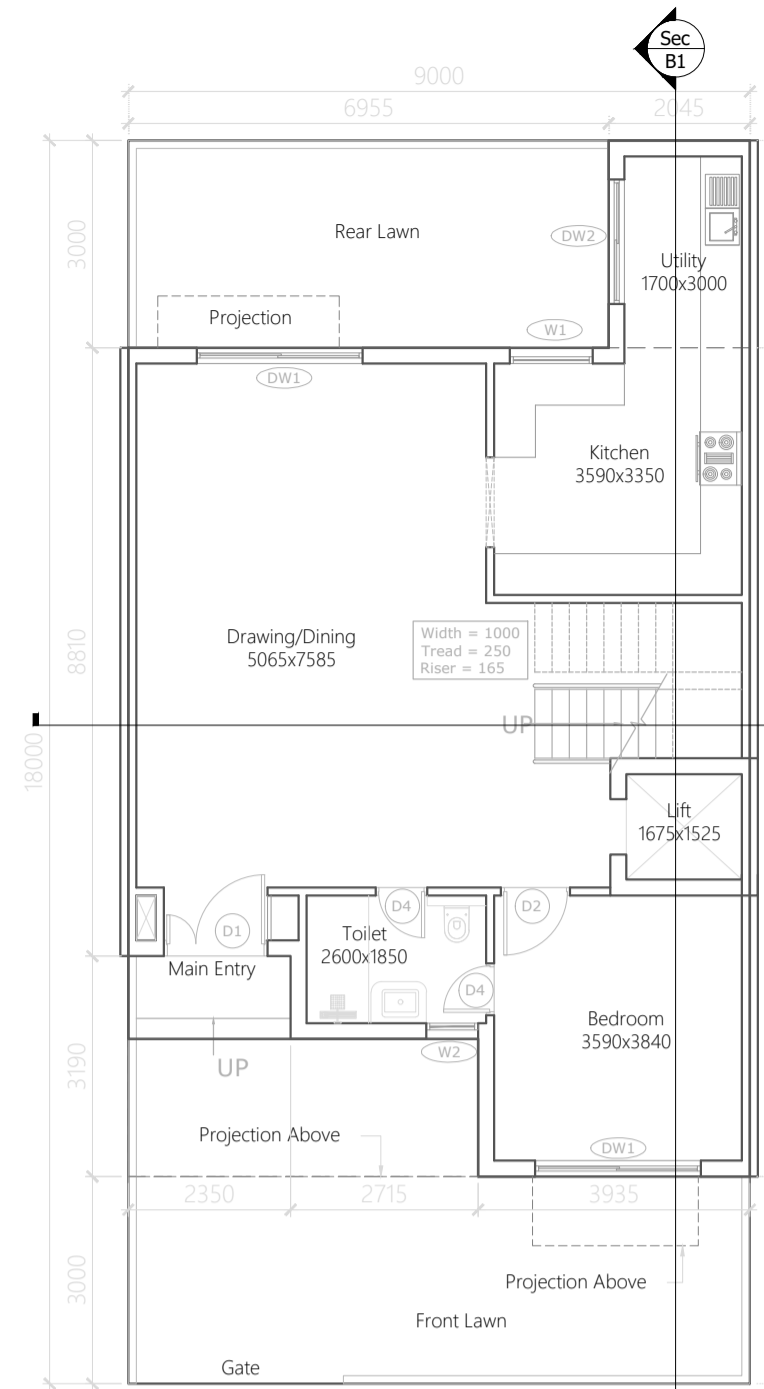

Ground Floor Plan
SCALE -1:100

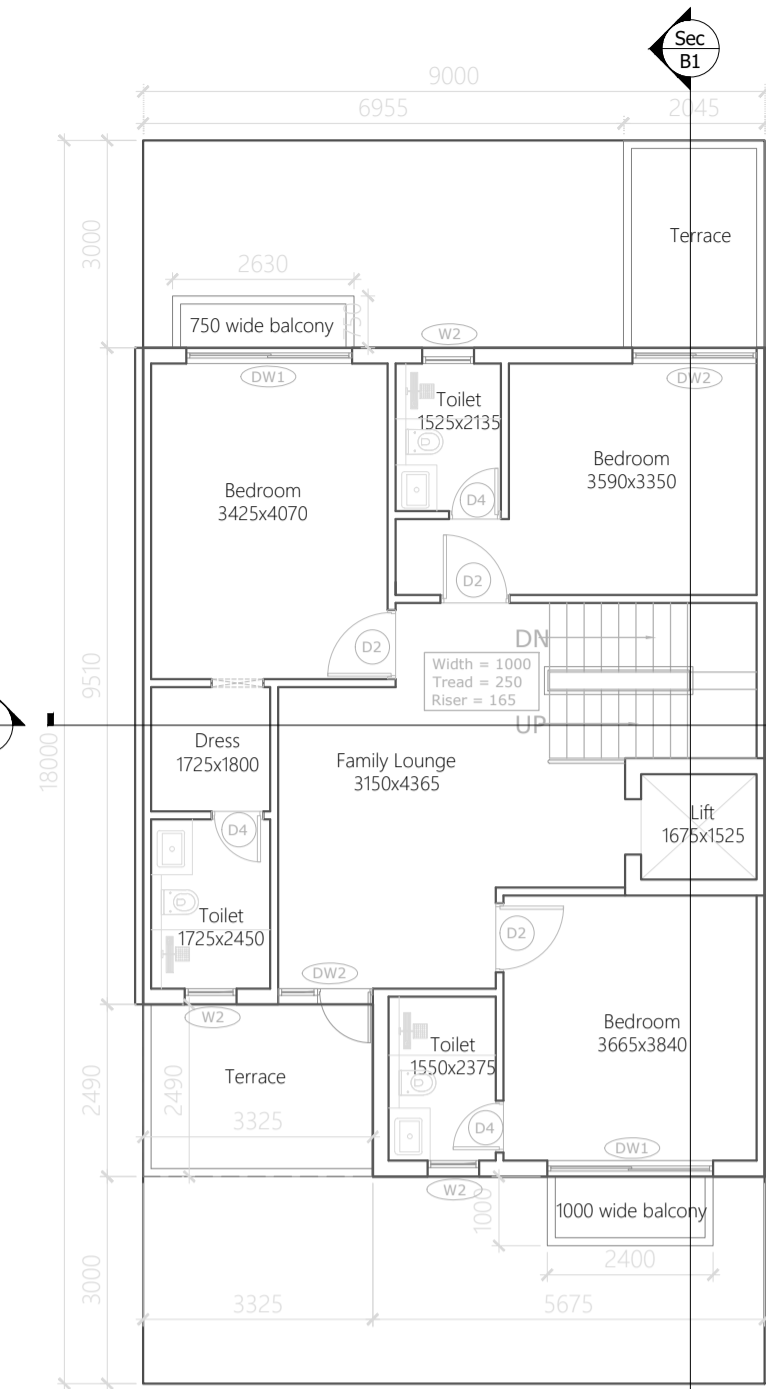

First Floor Plan
SCALE -1:100

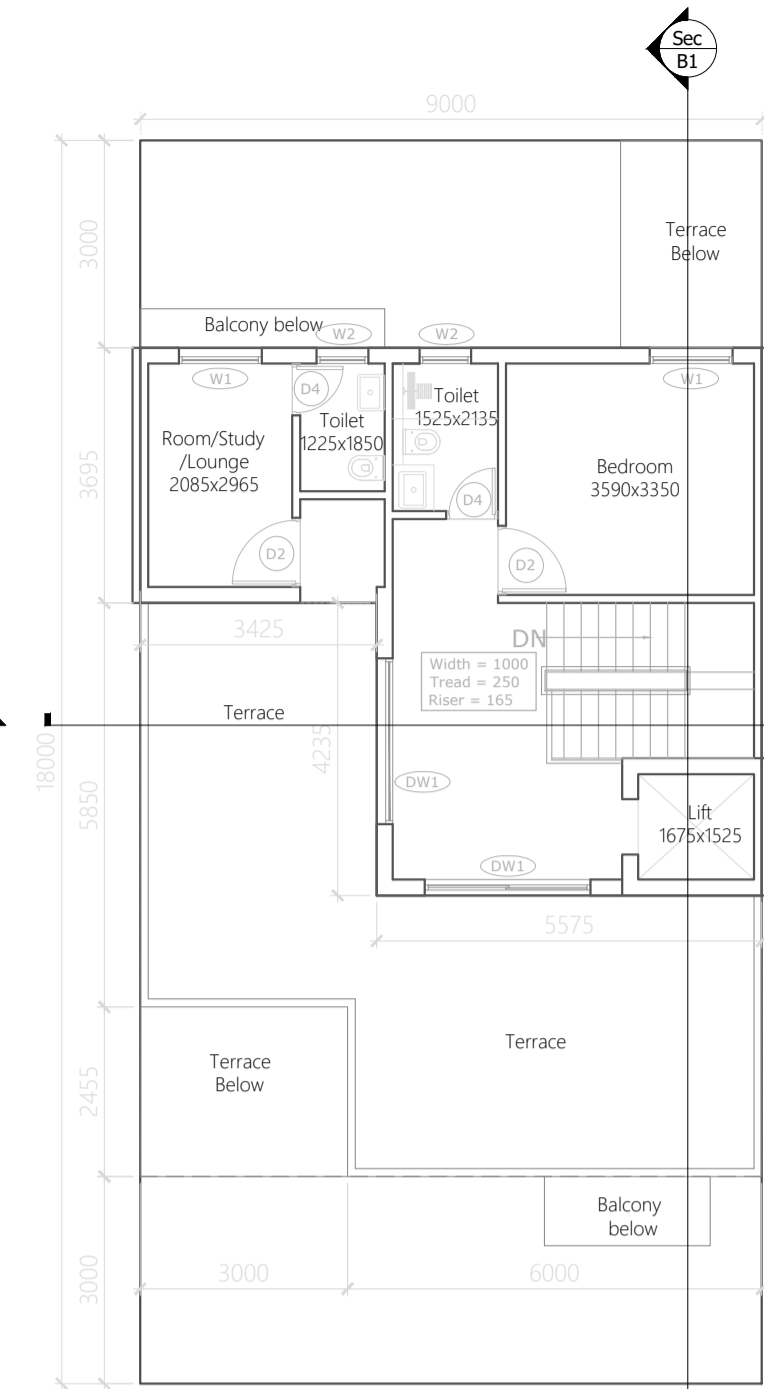

Second Floor Plan
SCALE -1:100

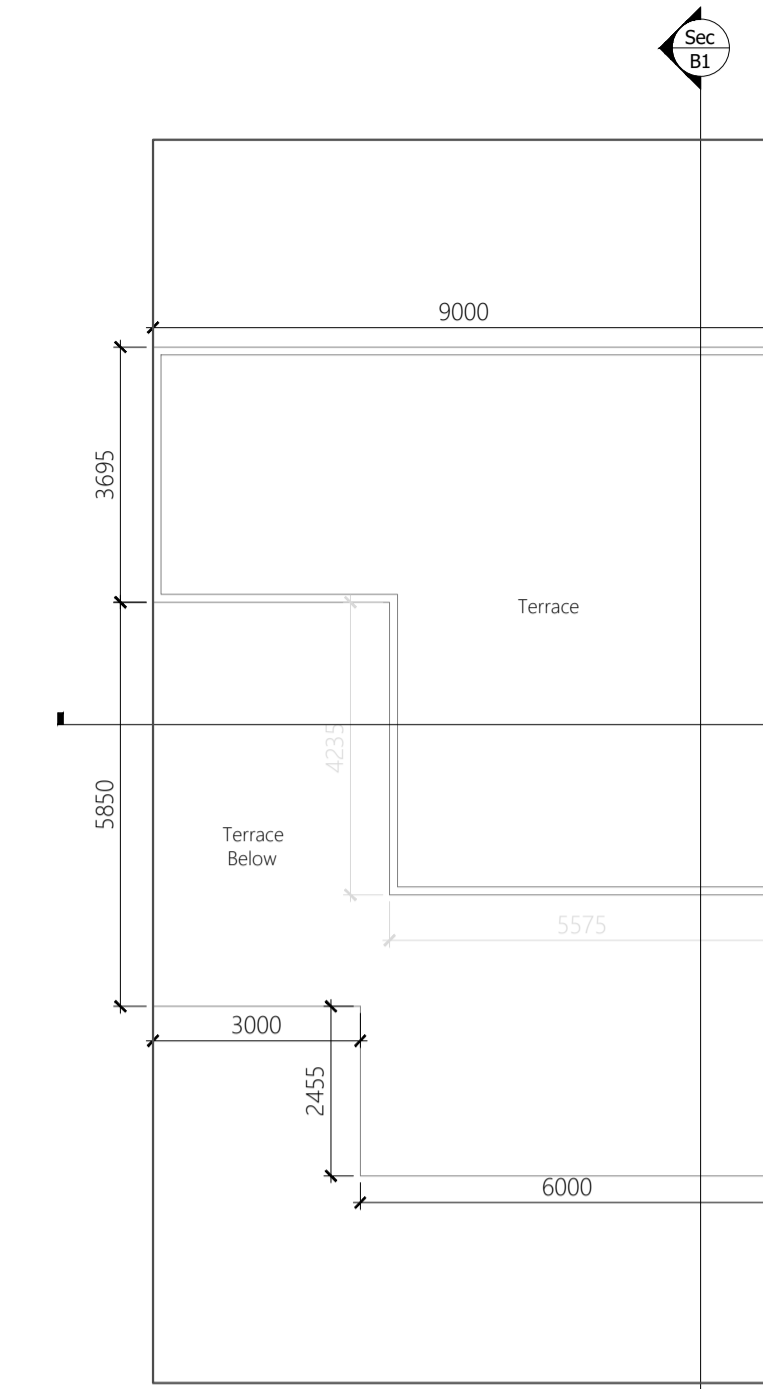

TERRACE Floor Plan
SCALE -1:100



Front Elevation
SCALE -1:100



Section-B1
SCALE -1:100

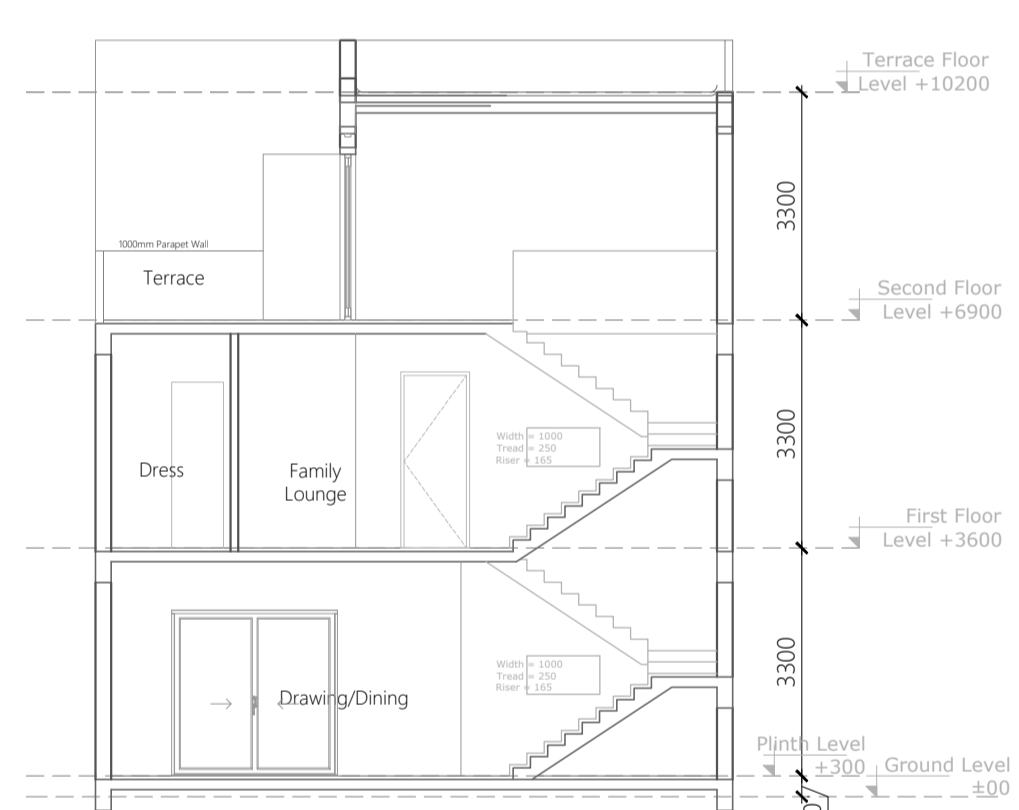

Section-A1
SCALE -1:100

Ground Floor Area Calculation				
Tag	Description	Size	Nos.	Area Sq.mtr.
1	Rectangle	2.045	3.000	6.135 Sq.mtr
2	Rectangle	9.000	10.100	90.900 Sq.mtr
3	Rectangle	3.935	1.990	7.831 Sq.mtr
Total				104.866 Sq.mtr

First Floor Area Calculation				
Tag	Description	Size	Nos.	Area Sq.mtr.
1	Rectangle	9.000	9.510	85.590 Sq.mtr
2	Rectangle	5.675	2.490	14.131 Sq.mtr
Total				99.721 Sq.mtr

Second Floor Area Calculation				
Tag	Description	Size	Nos.	Area Sq.mtr.
1	Rectangle	5.575	7.930	44.210 Sq.mtr
2	Rectangle	3.425	3.695	12.655 Sq.mtr
Total				56.865 Sq.mtr

NOTE :- ALL DIMENSIONS ARE IN MM

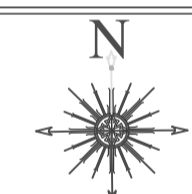

PROJECT ADDRESS:-

VILLA (9.0MX18.0M) IN
OMAXE HITECH CITY , LUCKNOW U.P.

OWNER NAME:-

OMAXE GARV BUILDTECH PVT LIMITED

This drawing is a "COPYRIGHT" contents of this drawing or part thereof may not be used or reproduced without the permission of the Architect

OWNER SIGNATURE



ARCHITECT SIGNATURE

Ar. Sachin Yadav
CA/2021/140419

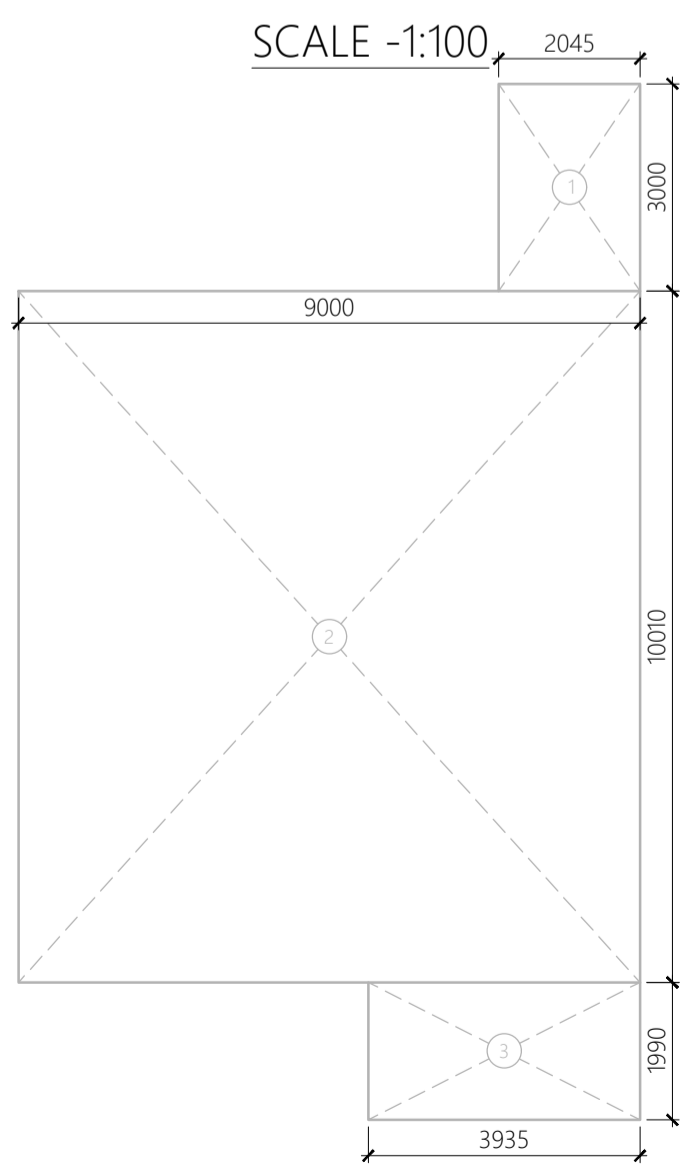

Area Envelope Plan of
Ground Floor

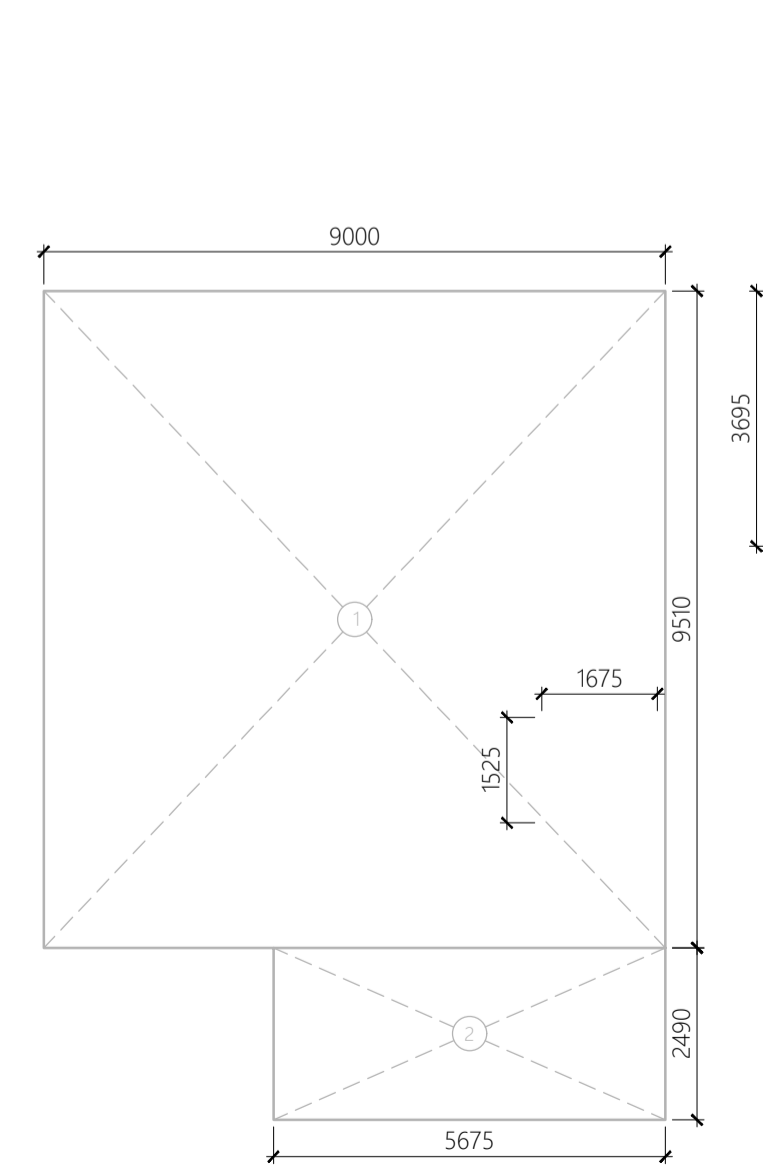

Area Envelope Plan of
First Floor

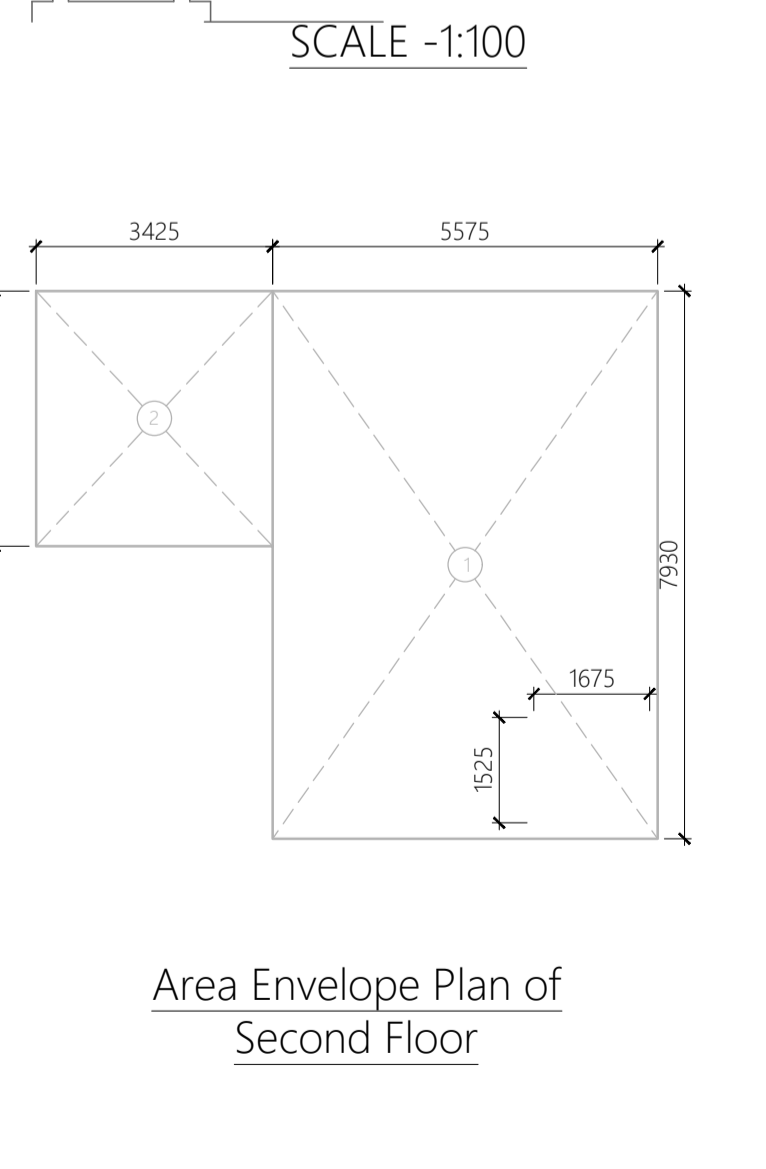

Area Envelope Plan of
Second Floor

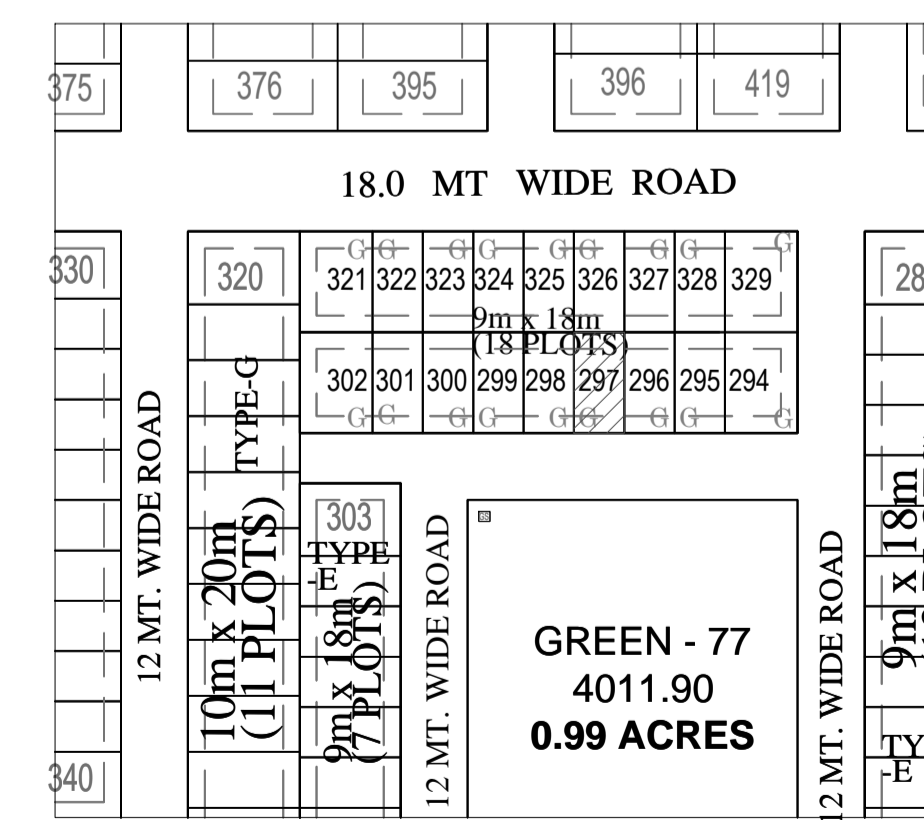

KEY PLAN
SCALE -1:100

DOOR - WINDOW SCHEDULE			
S. No.	Type	Size	Remark
1	DW1	2400x2400	Door/ Window
2	DW2	1800x2400	Door/ Window
3	DW2	1370x2400	Door/ Window
4	D1	1500x2400	Door
5	D2	1000x2400	Door
6	D3	900x2400	Door
7	D4	750x2400	Door
8	W1	1200x1500	Window
9	W2	750x1200	Window



FOR OFFICE :-

PROJECT TITLE-

PROPOSED RESIDENTIAL SUBMISSION DRAWING FOR THE VILLA ON PLOT NO - 298 P1 POCKET - L TYPE- E OMAXE HI-TECH CITY AT LUCKNOW

AREA STATEMENT

S.NO.	PARTICULARS	SQ.MTR.
1.	PLOT AREA	162.0
2.	PERMISSIBLE GROUND FLOOR COVERAGE (65%)	105.300
3.	PROPOSED GROUND COVERAGE(64.19%)	104.00
4.	PROPOSED FIRST FLOOR AREA	97.166
5.	PROPOSED SECOND FLOOR AREA	56.865
6.	PROPOSED TERRACE FLOOR AREA	0.0
7.	PROPOSED PORCH AREA	10.08
8.	PERMISSIBLE F. A. R. (2.0)	324.00
9.	PROPOSED F. A. R. = [G.F. + F.F.+S.F.](1.592)	258.031
10.	TOTAL COVERED AREA (3+4+5+6+7)	268.11

NOTE :- ALL DIMENSIONS ARE IN MM

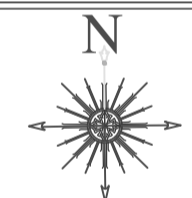

PROJECT ADDRESS:-

VILLA (9.0MX18.0M) IN OMAXE HITECH CITY , LUCKNOW U.P.

OWNER NAME:-

OMAXE GARV BUILDTech PVT LIMITED

This drawing is a "COPYRIGHT" contents of this drawing or part thereof may not be used or reproduced without the permission of the Architect

OWNER SIGNATURE



ARCHITECT SIGNATURE

Sachin Yadav
Ar. Sachin Yadav
CA/2021/140419

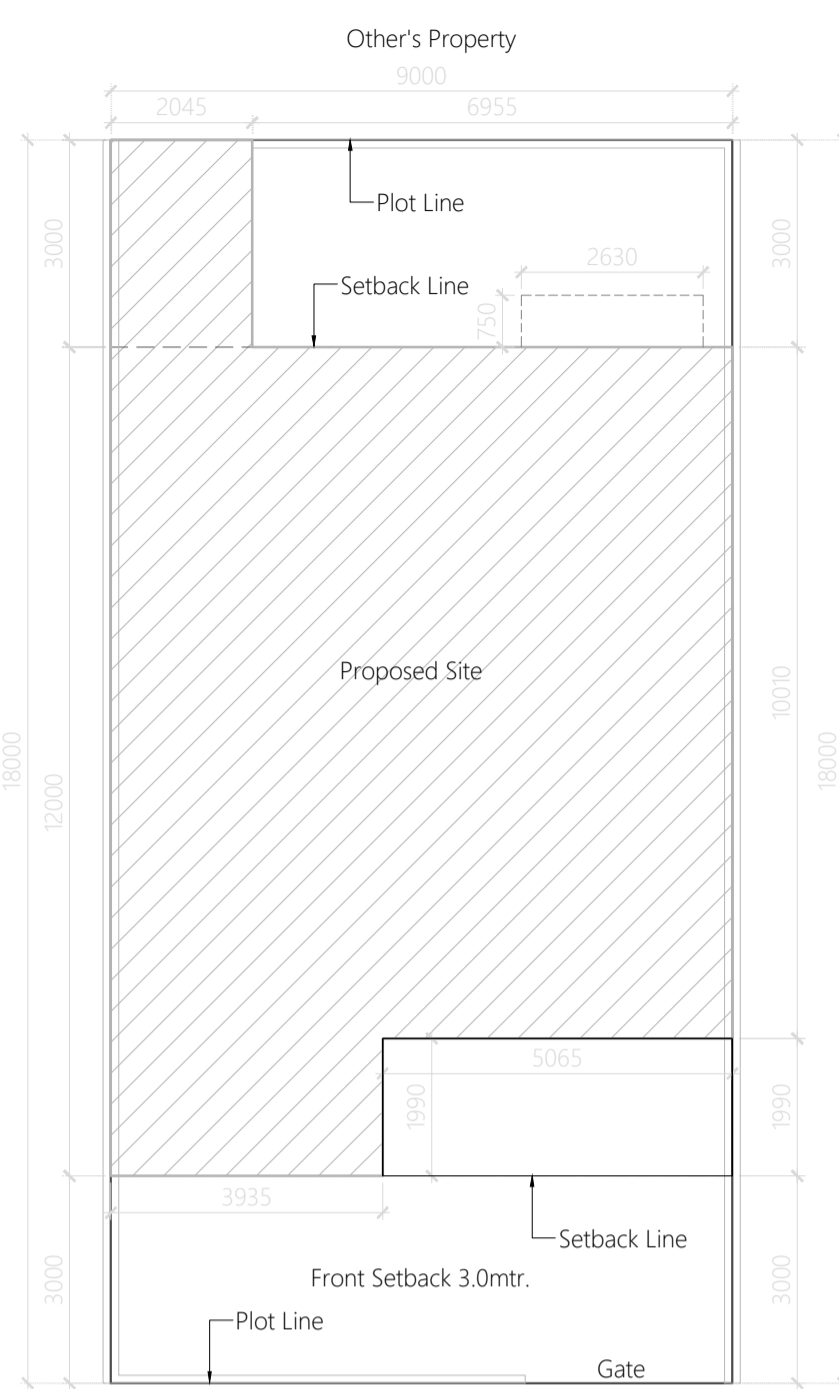

Site Plan
SCALE -1:100

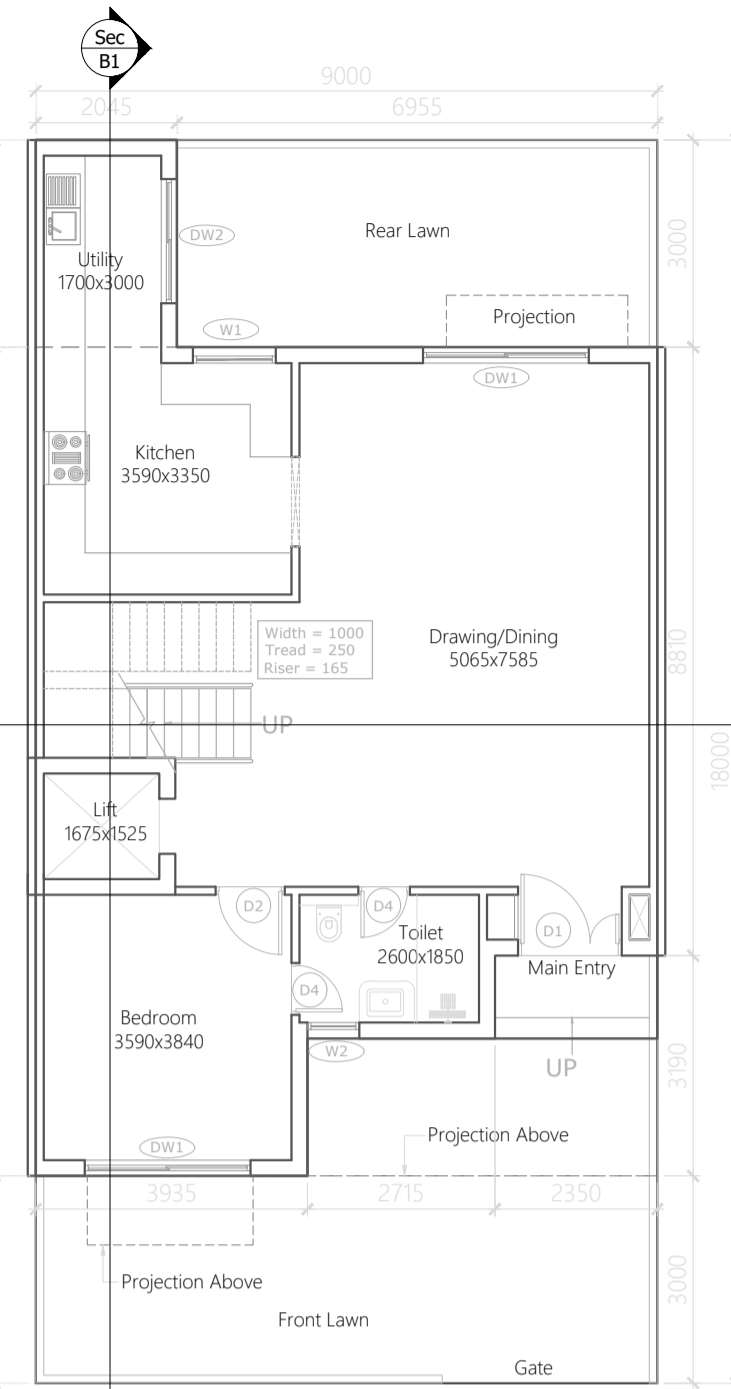

Ground Floor Plan
SCALE -1:100

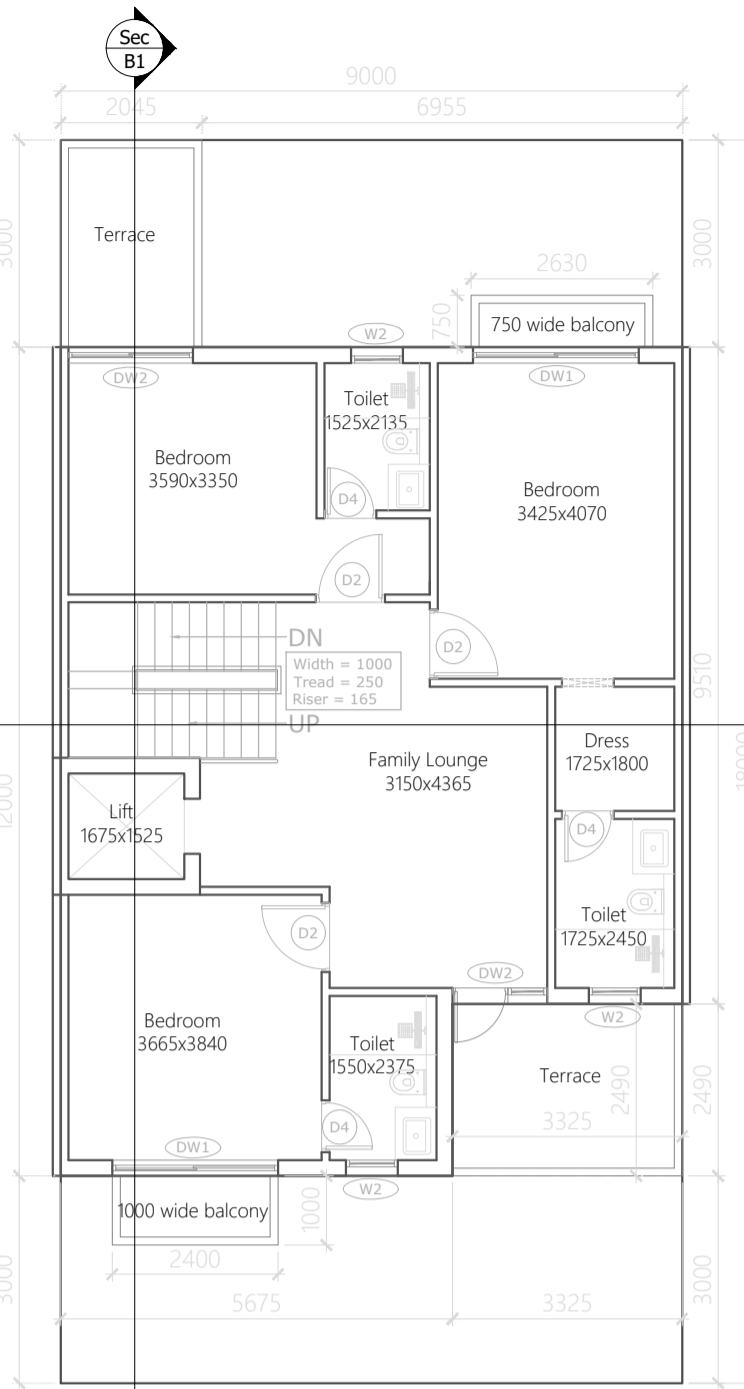

First Floor Plan
SCALE -1:100

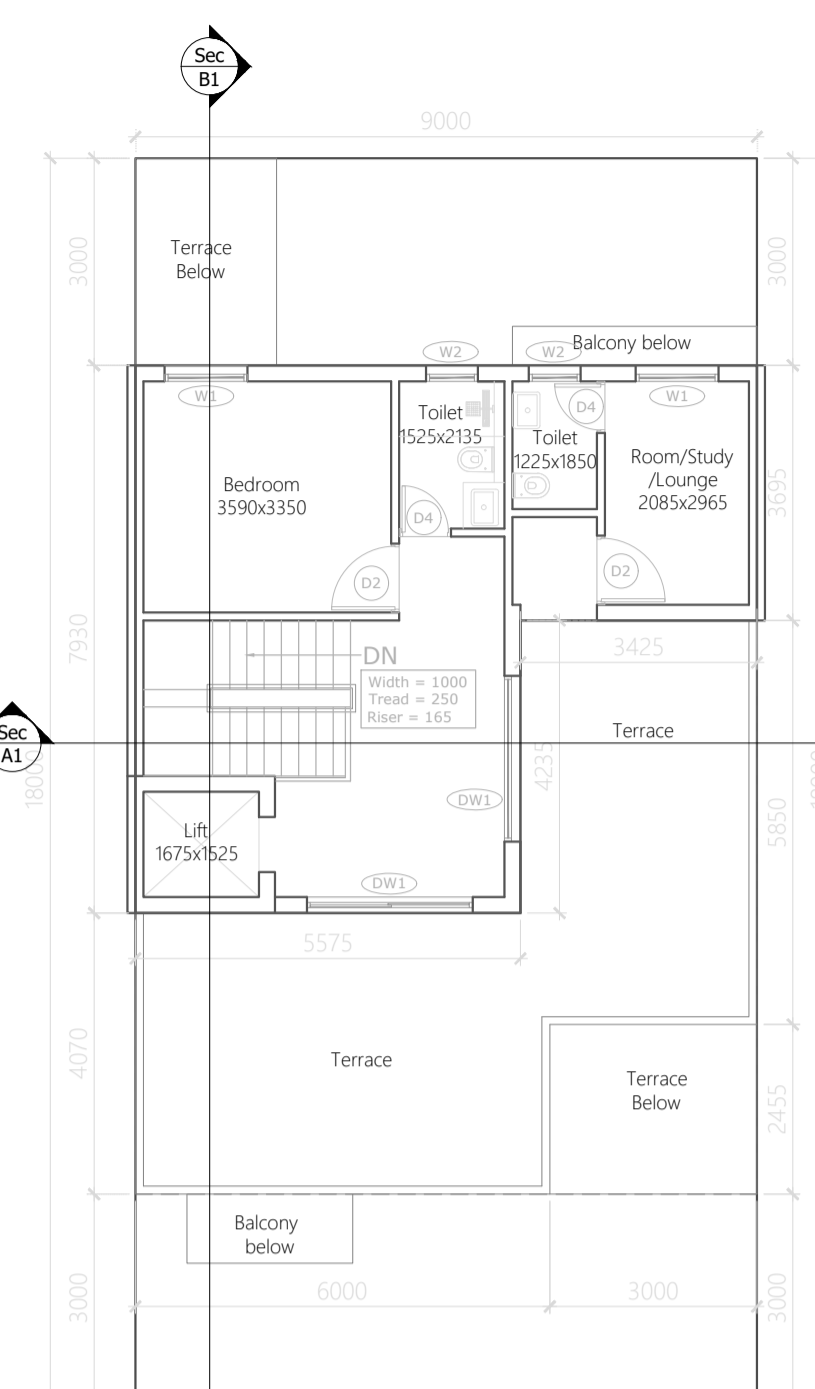

Second Floor Plan
SCALE -1:100

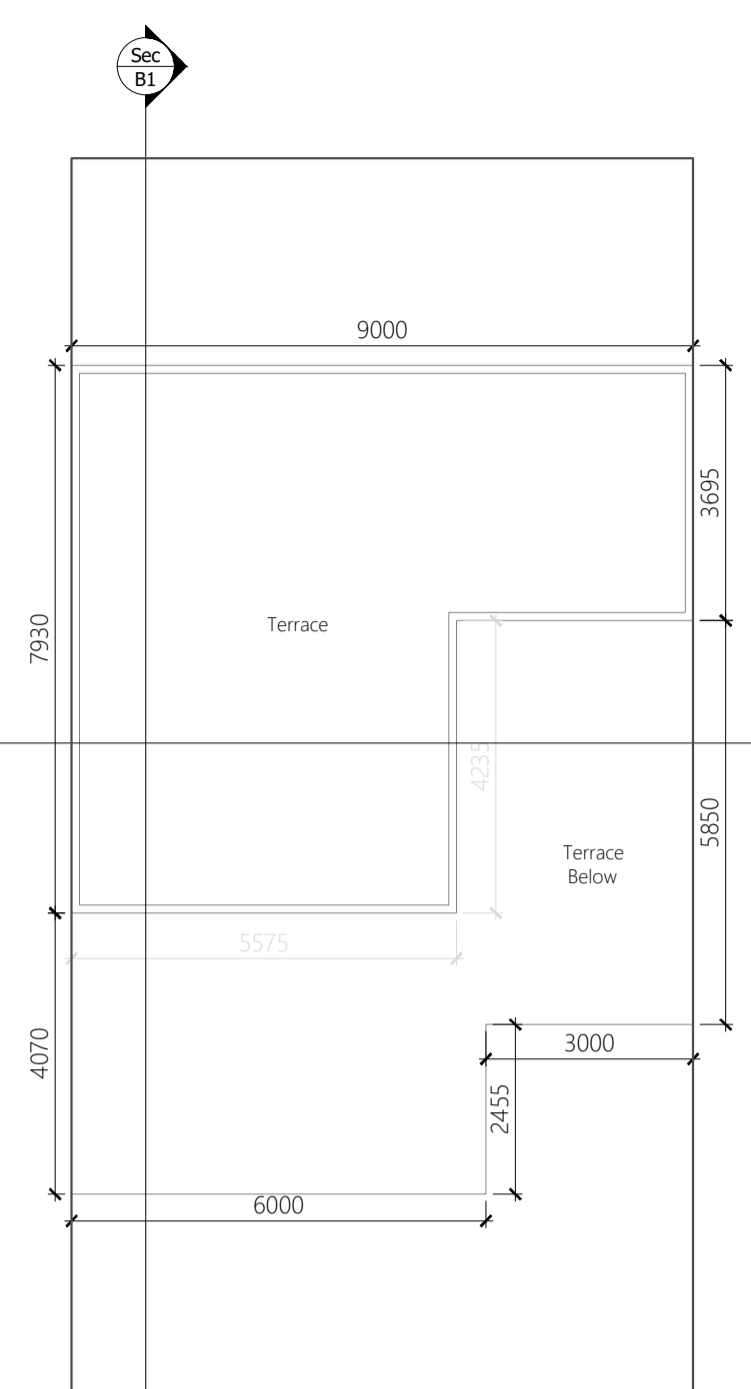

TERRACE Floor Plan
SCALE -1:100



Front Elevation
SCALE -1:100

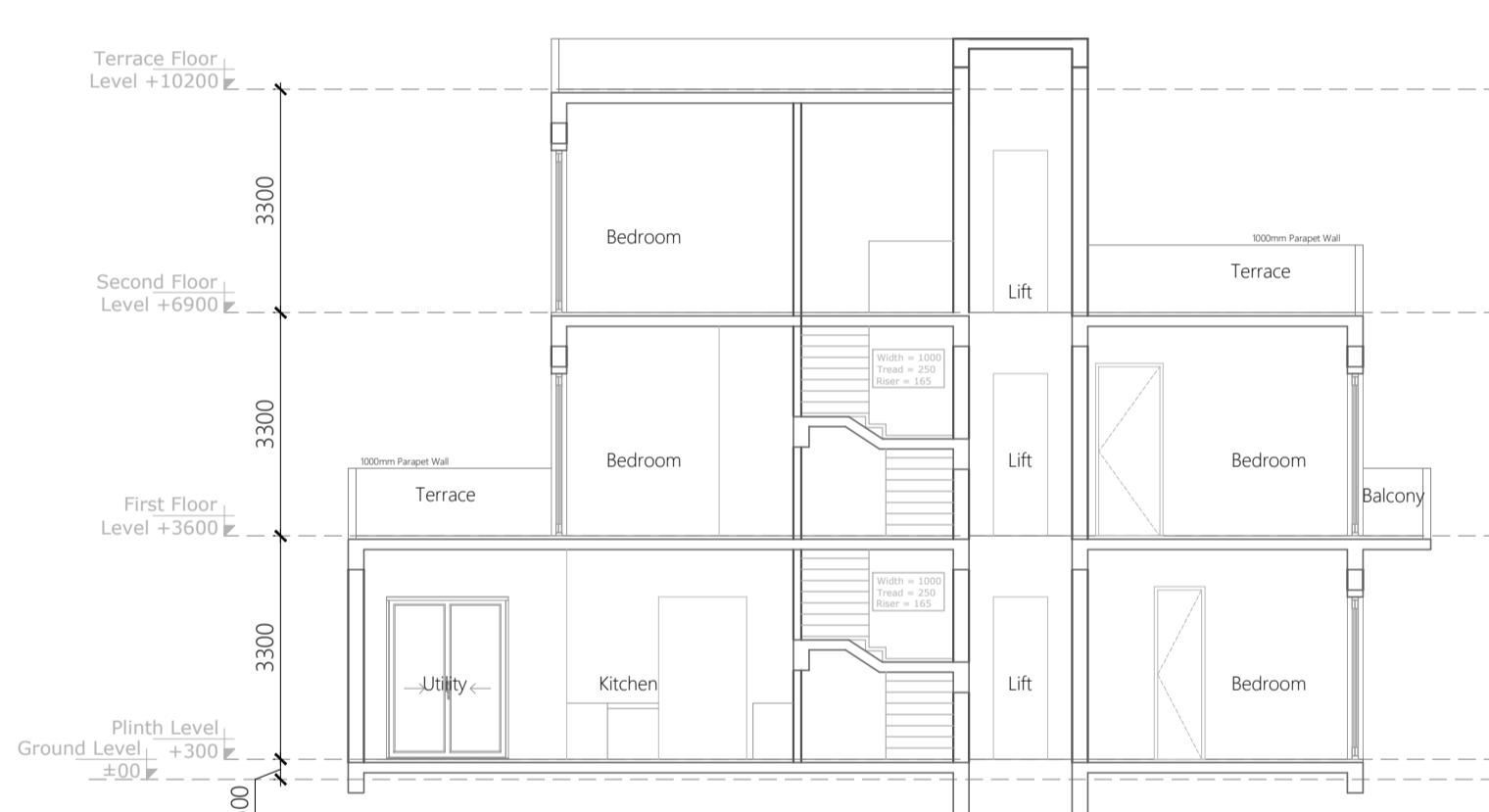

Section-B1
SCALE -1:100

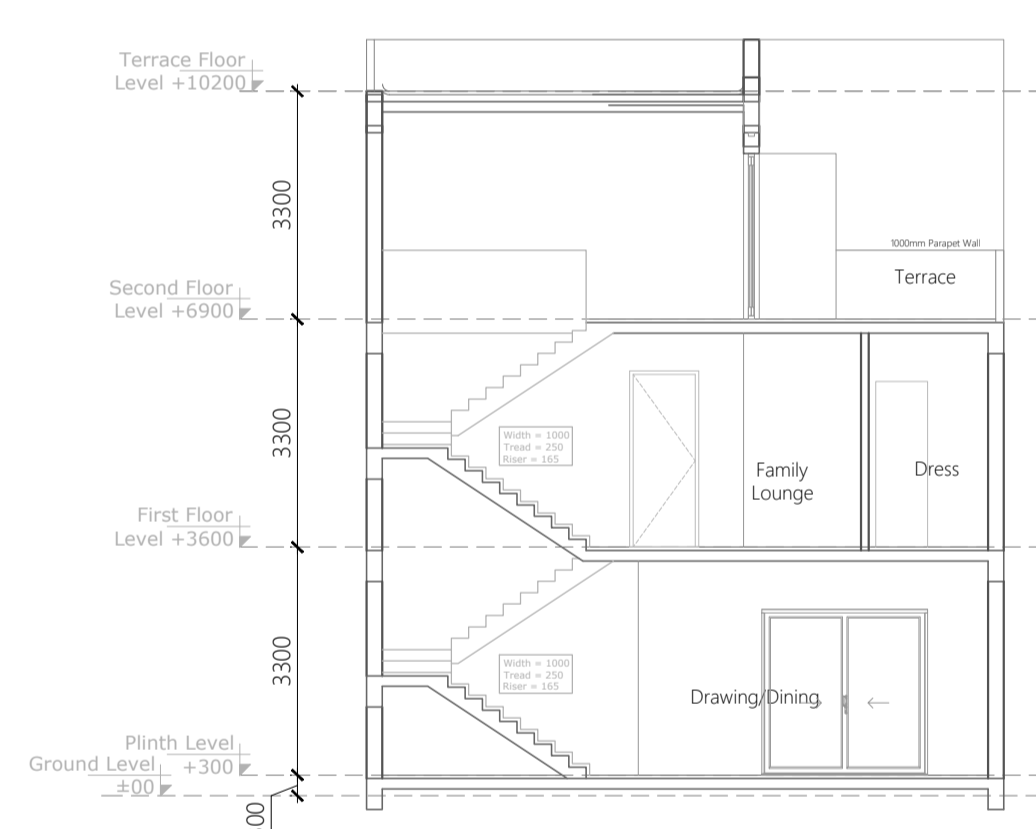

Section-A1
SCALE -1:100

Ground Floor Area Calculation

Tag	Description	Size	No.	Area Sq.mtr.	Remark
1	Rectangle	2.045 x 3.000	1	6.135	Sq.mtr.
2	Rectangle	3.000 x 3.000	1	9.000	Sq.mtr.
3	Rectangle	3.025 x 3.000	1	9.075	Sq.mtr.
Total				24.210	Sq.mtr.

First Floor Area Calculation

Tag	Description	Size	No.	Area Sq.mtr.	Remark
1	Rectangle	3.000 x 3.000	1	9.000	Sq.mtr.
2	Rectangle	3.025 x 2.400	1	7.260	Sq.mtr.
Total				16.260	Sq.mtr.

Second Floor Area Calculation

Tag	Description	Size	No.	Area Sq.mtr.	Remark
1	Rectangle	3.025 x 3.025	1	9.151	Sq.mtr.
2	Rectangle	3.025 x 3.000	1	9.075	Sq.mtr.
Total				18.226	Sq.mtr.

Area For Deduction

Tag	Description	Size	No.	Area Sq.mtr.	Remark
1	Rectangle	3.025 x 3.025	1	9.151	Sq.mtr.
2	Rectangle	3.025 x 3.000	1	9.075	Sq.mtr.
Total				18.226	Sq.mtr.

DOOR - WINDOW SCHEDULE

S. No.	Type	Size	Remark
1	DW1	2400x2400	Door/ Window
2	DW2	1800x2400	Door/ Window
3	DW2	1370x2400	Door/ Window
4	D1	1500x2400	Door
5	D2	1000x2400	Door
6	D3	900x2400	Door
7	D4	750x2400	Door
8	W1	1200x1500	Window
9	W2	750x1200	Window

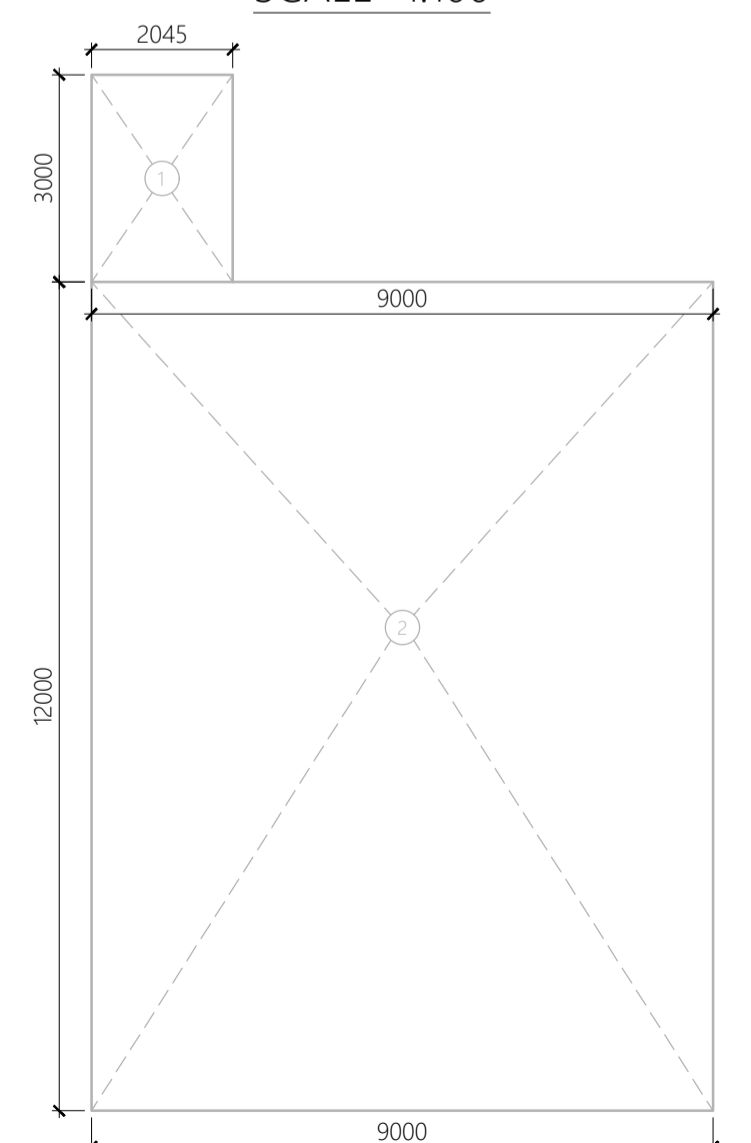

Area Envelope Plan of
Ground Floor

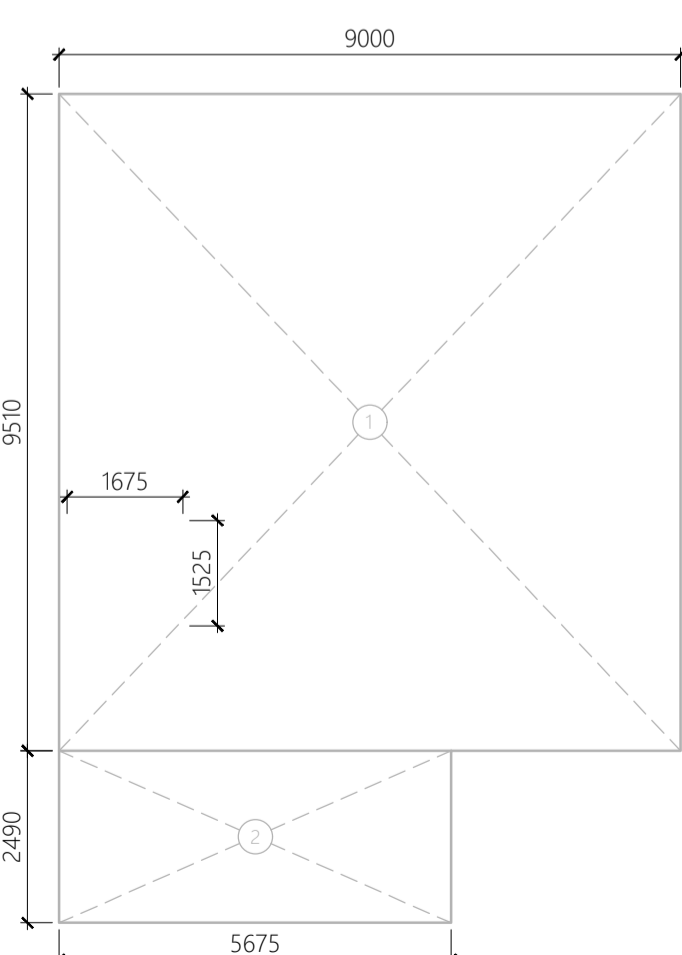

Area Envelope Plan of
First Floor

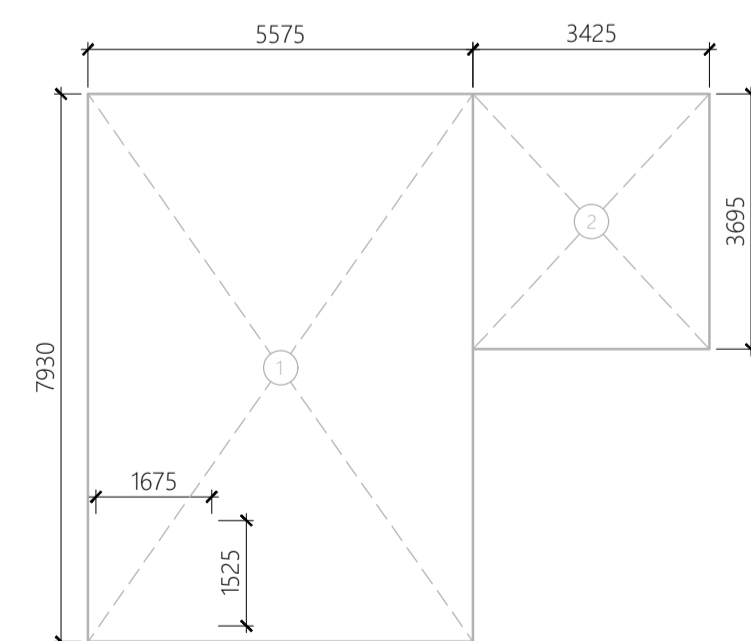

Area Envelope Plan of
Second Floor

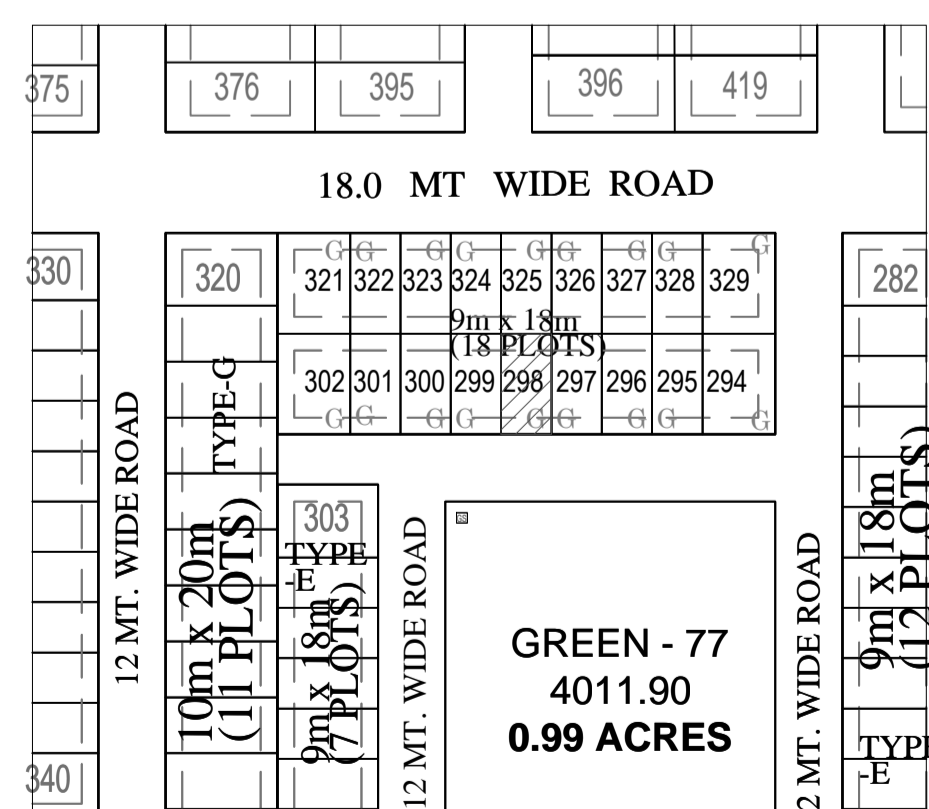

KEY PLAN
SCALE -1:100



Lucknow Development Authority