

**AREA CHART**

**PLOT AREA = 16345.44 SQMT.**

**PARK (GREEN AREA 15%) = 2451.82 SQMT.**

**COMMERCIAL PLOT AREA (5.0%) = 817.27 SQMT.**

**TOTAL PLOTTED AREA = 8195.17 SQMT.**

**COMMERCIAL PLOT AREA = 817.27 SQMT.**

**TOTAL ROAD & PATHWAY AREA = 4880.85 SQMT.**

**PARK (GREEN) AREA PROVIDED = 2452.15 SQMT.**

PLOT NO.	PLOT SIZE	PLOT AREA	SET BACK		
			F.S.B.	R.S.B.	S.S.B.
01	24.179 + 24.5312 X	301.95 SQMT.	3.00 M.	3.00 M.	3.00 M.
02	24.331 + 24.815 X 10.00	246.73 SQMT.	3.00 M.	3.00 M.	---
03	24.815 + 25.099 X 10.00	248.57 SQMT.	3.00 M.	3.00 M.	---
04	25.099 + 25.382 X 10.00	252.40 SQMT.	3.00 M.	3.00 M.	---
05	12.398 + 13.445 X 25.382	327.97 SQMT.	3.00 M.	3.00 M.	3.00 M.
06	11.55 X 20.00	231.00 SQMT.	3.00 M.	3.00 M.	3.00 M.
07 TO 10	10.00 X 20.00	200.00 SQMT.	3.00 M.	3.00 M.	---
11	11.55 + 11.864 X 20.00	234.24 SQMT.	3.00 M.	3.00 M.	3.00 M.
12	11.864 + 12.166 X 20.00	240.30 SQMT.	3.00 M.	3.00 M.	3.00 M.
13 TO 16	10.00 X 20.00	200.00 SQMT.	3.00 M.	3.00 M.	---
17	11.55 X 20.00	231.00 SQMT.	3.00 M.	3.00 M.	3.00 M.
18	9.273 X 18.00	166.91 SQMT.	3.00 M.	3.00 M.	3.00 M.
19 TO 23	9.00 X 18.00	162.00 SQMT.	3.00 M.	3.00 M.	---
24	9.565 + 9.419 X 18.00	170.86 SQMT.	3.00 M.	3.00 M.	3.00 M.
25	9.419 + 9.273 X 18.00	168.23 SQMT.	3.00 M.	3.00 M.	3.00 M.
26 TO 30	9.00 X 18.00	162.00 SQMT.	3.00 M.	3.00 M.	---
31	9.273 X 18.00	166.91 SQMT.	3.00 M.	3.00 M.	3.00 M.
32	22.205 + 21.5392 X 8.987	196.56 SQMT.	2.00 M.	2.00 M.	2.00 M.
33	21.539 + 21.010 X 7.00	148.92 SQMT.	2.00 M.	2.00 M.	---
34	21.010 + 20.482 X 7.00	145.22 SQMT.	2.00 M.	2.00 M.	---
35	20.482 + 19.953 X 7.00	141.52 SQMT.	2.00 M.	2.00 M.	---
36	19.953 + 19.424 X 7.00	137.82 SQMT.	2.00 M.	2.00 M.	---
37	19.424 + 18.895 X 7.00	134.12 SQMT.	2.00 M.	2.00 M.	---
38	18.895 + 18.411 X 7.00	130.61 SQMT.	2.00 M.	2.00 M.	---
39	18.411 + 17.915 X 7.00	127.14 SQMT.	2.00 M.	2.00 M.	2.00 M.
40	17.915 + 17.418 X 7.00	123.74 SQMT.	2.00 M.	2.00 M.	2.00 M.
41	17.418 X 12.00	90.00 SQMT.	1.50 M.	1.50 M.	---
42	17.418 X 12.00	90.00 SQMT.	1.50 M.	1.50 M.	---
43 & 44	6.304 X 12.00	75.65 SQMT.	1.50 M.	1.50 M.	---
45	7.50 + 6.099 X 12.00	81.35 SQMT.	1.50 M.	1.50 M.	1.50 M.
46	7.50 + 11.315 X 12.00	112.89 SQMT.	1.50 M.	1.50 M.	1.50 M.
47	6.00 X 14.84	89.04 SQMT.	1.50 M.	1.50 M.	---
48	6.00 X 14.84	89.04 SQMT.	1.50 M.	1.50 M.	1.50 M.
49	12.718 X 6.572 + 16.574 + 16.8 X 2 X 1.008	55.65 SQMT.	1.50 M.	1.50 M.	---
TOTAL PLOTTED AREA		8195.17 SQMT.			

**POPULATION DENSITY**

750 UNIT / HECTARE  
FOR 16345.44 SQMT. = 1225.91 UNIT FOR 49 PLOTS

15X2X5 + 32X4X5 + 2X3X5 = 150+640+30 = 820 UNIT WHICH IS WITHIN LIMIT

**COMMERCIAL PLOT AREA**

PLOT NO.	PLOT SIZE	PLOT AREA	F.S.B.	SET BACK	R.S.B.	S.S.B.
01	11.84 + 11.170 X 14.40	165.67 SQMT.	3.00 M.	---	---	---
02	11.169 + 11.172 X 14.40	160.85 SQMT.	3.00 M.	---	---	---
03	(14.40X11.172) + (11.169X14.5342)	161.60 SQMT.	3.00 M.	---	---	---
04	(14.534X11.172) + (11.169X14.7932)	163.74 SQMT.	3.00 M.	---	---	---
05	(14.793X11.172) + (11.327X14.952)	165.41 SQMT.	3.00 M.	---	---	3.00 M.
TOTAL COMMERCIAL PLOTTED AREA		817.27 SQMT.				

**PROJECT:**

PROPOSED LAYOUT PLAN FOR MR. JAYSUKH PAREKH , MR. HASMUKH PAREKH , MR. MEHUL JAYASUKH PAREKH & MR. NIKHIL PAREKH ON PLOT NO. - GH-1A RATAN KHAND , SHARDA NAGAR SCHEME , LUCKNOW.

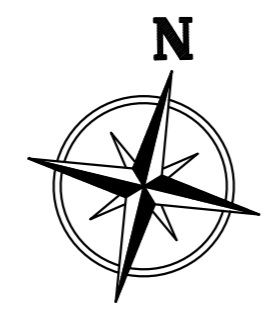

**OWNERS:**

**ARCHITECT:**



3rd Floor, Ashwarya Plaza-1, Sector H, Aliganj, Lucknow  
E-Mail: info.shaleenconsultants@gmail.com  
Contact No: +91 933932481 / 91 899682208

THIS MAP HAS BEEN PREPARED UNDER MASTER PLAN 2031/BHAWAN UPVIDHI 2008

**SITE PLAN**  
(Scale - 1:500)

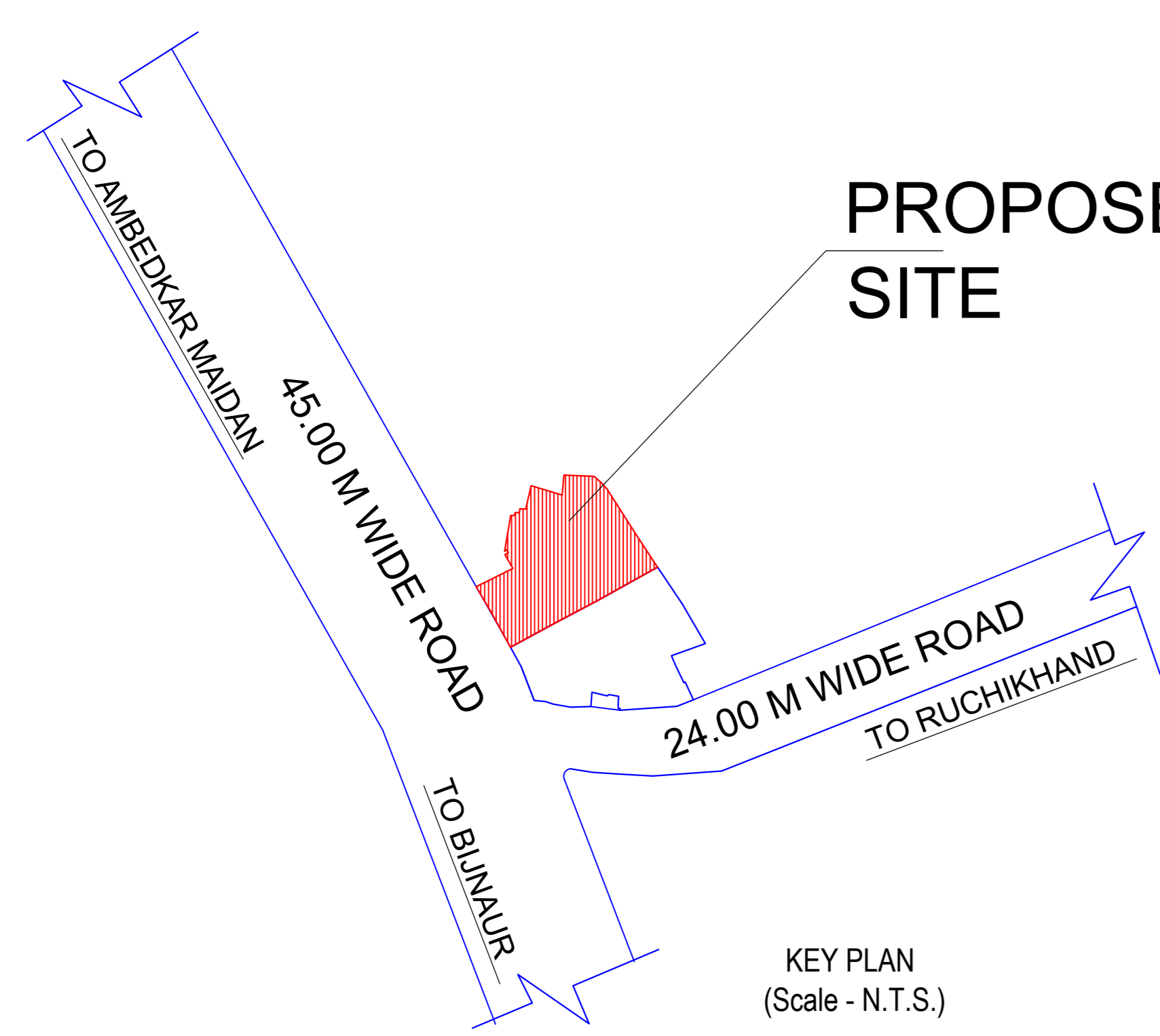

**KEY PLAN**  
(Scale - N.T.S.)

**Individual Plot Area**

Plot No.	Abutting Road	Plot Area	Frontage		Coverage		FSI Area		
			Rept	Prop	Perm	Prop	Perm	Prop	
01	9.00 M WIDE ROAD	40.00	301.95	3.50	36.58	0.00	0.00	0.00	0.00
02	9.00 M WIDE ROAD	40.00	246.73	3.50	10.00	0.00	0.00	0.00	0.00
03	9.00 M WIDE ROAD	40.00	248.57	3.50	10.00	0.00	0.00	0.00	0.00
04	9.00 M WIDE ROAD	40.00	252.40	3.50	10.00	0.00	0.00	0.00	0.00
05	9.00 M WIDE ROAD	40.00	330.25	3.50	12.40	0.00	0.00	0.00	0.00
06	9.00 M WIDE ROAD	40.00	231.00	3.50	31.55	0.00	0.00	0.00	0.00
07	9.00 M WIDE ROAD	40.00	200.00	3.50	10.00	0.00	0.00	0.00	0.00
08	9.00 M WIDE ROAD	40.00	200.00	3.50	10.00	0.00	0.00	0.00	0.00
09	9.00 M WIDE ROAD	40.00	200.00	3.50	10.00	0.00	0.00	0.00	0.00
10	9.00 M WIDE ROAD	40.00	200.00	3.50	10.00	0.00	0.00	0.00	0.00
11	9.00 M WIDE ROAD	40.00	234.25	3.50	20.00	0.00	0.00	0.00	0.00
12	9.00 M WIDE ROAD	40.00	240.30	3.50	32.17	0.00	0.00	0.00	0.00
13	9.00 M WIDE ROAD	40.00	200.00	3.50	10.00	0.00	0.00	0.00	0.00
14	9.00 M WIDE ROAD	40.00	200.00	3.50	10.00	0.00	0.00	0.00	0.00
15	9.00 M WIDE ROAD	40.00	200.00	3.50	10.00	0.00	0.00	0.00	0.00
16	9.00 M WIDE ROAD	40.00	200.00	3.50	10.00	0.00	0.00	0.00	0.00
17	9.00 M WIDE ROAD	40.00	231.00	3.50	31.55	0.00	0.00	0.00	0.00
18	9.00 M WIDE ROAD	40.00	166.91	3.50	9.00	0.00	0.00	0.00	0.00
19	9.00 M WIDE ROAD	40.00	162.00	3.50	9.00	0.00	0.00	0.00	0.00
20	9.00 M WIDE ROAD	40.00	162.00	3.50	9.00	0.00	0.00	0.00	0.00
21	9.00 M WIDE ROAD	40.00	162.00	3.50	9.00	0.00	0.00	0.00	0.00
22	9.00 M WIDE ROAD	40.00	162.00	3.50	9.00	0.00	0.00	0.00	0.00
23	9.00 M WIDE ROAD	40.00	162.00	3.50	9.00	0.00	0.00	0.00	0.00
24	9.00 M WIDE ROAD	40.00	170.87	3.50	27.57	0.00	0.00	0.00	0.00
25	9.00 M WIDE ROAD	40.00	168.23	3.50	27.27	0.00	0.00	0.00	0.00
26	9.00 M WIDE ROAD	40.00	162.00	3.50	9.00	0.00	0.00	0.00	0.00
27	9.00 M WIDE ROAD	40.00	162.00	3.50	9.00	0.00	0.00	0.00	0.00
28	9.00 M WIDE ROAD	40.00	162.00	3.50	9.00	0.00	0.00	0.00	0.00
29	9.00 M WIDE ROAD	40.00	162.00	3.50	9.00	0.00	0.00	0.00	0.00
30	9.00 M WIDE ROAD	40.00	162.00	3.50	9.00	0.00	0.00	0.00	0.00
31	9.00 M WIDE ROAD	40.00	166.91	3.50	27.27	0.00	0.00	0.00	0.00
32	9.00 M WIDE ROAD	40.00	194.63	3.50	8.99	0.00	0.00	0.00	0.00
33	9.00 M WIDE ROAD	40.00	148.92	3.50	7.00	0.00	0.00	0.00	0.00
34	9.00 M WIDE ROAD	40.00	145.22	3.50	7.00	0.00	0.00	0.00	0.00
35	9.00 M WIDE ROAD	40.00	141.52	3.50	7.00	0.00	0.00	0.00	0.00
36	9.00 M WIDE ROAD	40.00	137.82	3.50	7.00	0.00	0.00	0.00	0.00
37	9.00 M WIDE ROAD	40.00	134.12	3.50	7.00	0.00	0.00	0.00	0.00
38	9.00 M WIDE ROAD	40.00	130.61	3.50	7.00	0.00	0.00	0.00	0.00
39	9.00 M WIDE ROAD	40.00	127.14	3.50	7.00	0.00	0.00	0.00	0.00
40	9.00 M WIDE ROAD	40.00	123.74	3.50	7.00	0.00	0.00	0.00	0.00
41	9.00 M WIDE ROAD	40.00	153.67	3.50	25.77	0.00	0.00	0.00	0.00
42	9.00 M WIDE ROAD	40.00	90.00	3.50	19.90	0.00	0.00	0.00	0.00
43	9.00 M WIDE ROAD	40.00	75.65	3.50	6.30	0.00	0.00	0.00	0.00
44	9.00 M WIDE ROAD	40.00	75.65	3.50	6.30	0.00	0.00	0.00	0.00
45	9.00 M WIDE ROAD	40.00	75.65	3.50	6.30	0.00	0.00	0.00	0.00
46	9.00 M WIDE ROAD	40.00	83.83	3.50	7.50	0.00	0.00	0.00	0.00
47	9.00 M WIDE ROAD	40.00	114.85	3.50	7.50	0.00	0.00	0.00	0.00
48	9.00 M WIDE ROAD	40.00	89.04	3.50	20.84	0.00	0.00	0.00	0.00
49	9.00 M WIDE ROAD	40.00	55.65	3.50	13.72	0.00	0.00	0.00	0.00

**Proposed Population Calculation**

Plot No.	Use	Sub Use	Range	No.	Perm. Unit	Perm. Person	Total Person/Plot	Total
43	Residential	Row House	10-15	2	2	10	10	10
44	Residential	Row House	10-15	2	2	10	10	10
45	Residential	Row House	10-15	2	2	10	10	10
46	Residential	Row House	10-15	2	2	10	10	10
47	Residential	Row House	10-15	2	2	10	10	10
48	Residential	Row House	10-15	2	2	10	10	10
49	Residential	Row House	10-15	2	2	10	10	10
10	Residential	Row House	10-15	2	2	10	10	10
11	Residential	Row House	10-15	2	2	10	10	10
12	Residential	Row House	10-15	2	2	10	10	10
13	Residential	Row House	10-15	2	2	10	10	10
14	Residential	Row House	10-15	2	2	10	10	10
15	Residential	Row House	10-15	2	2	10	10	10
16	Residential	Row House	10-15	2	2	10	10	10
17	Residential	Row House	10-15	2	2	10	10	10
18	Residential	Row House	10-15	2	2	10	10	10
19	Residential	Row House	10-15	2	2	10	10	10
20	Residential	Row House	10-15	2	2	10	10	10
21	Residential	Row House	10-15	2	2	10	10	10
22	Residential	Row House	10-15	2	2	10	10	10
23	Residential	Row House	10-15	2	2	10	10	10
24	Residential	Row House	10-15	2	2	10	10	10
25	Residential	Row House	10-15	2	2	10	10	10
26	Residential	Row House	10-15	2	2	10	10	10
27	Residential	Row House	10-15	2	2	10	10	10
28	Residential	Row House	10-15	2	2	10	10	10
29	Residential	Row House	10-15	2	2	10	10	10
30	Residential	Row House	10-15	2	2	10	10	10
31	Residential	Row House	10-15	2	2	10	10	10
32	Residential	Row House	10-15	2	2	10	10	10
33	Residential	Row House	10-15	2	2	10	10	10
34	Residential	Row House	10-15	2	2	10	10	10
35	Residential	Row House	10-15	2	2	10	10	10
36	Residential	Row House	10-15	2	2	10	10	10
37	Residential	Row House	10-15	2	2	10	10	10
38	Residential							

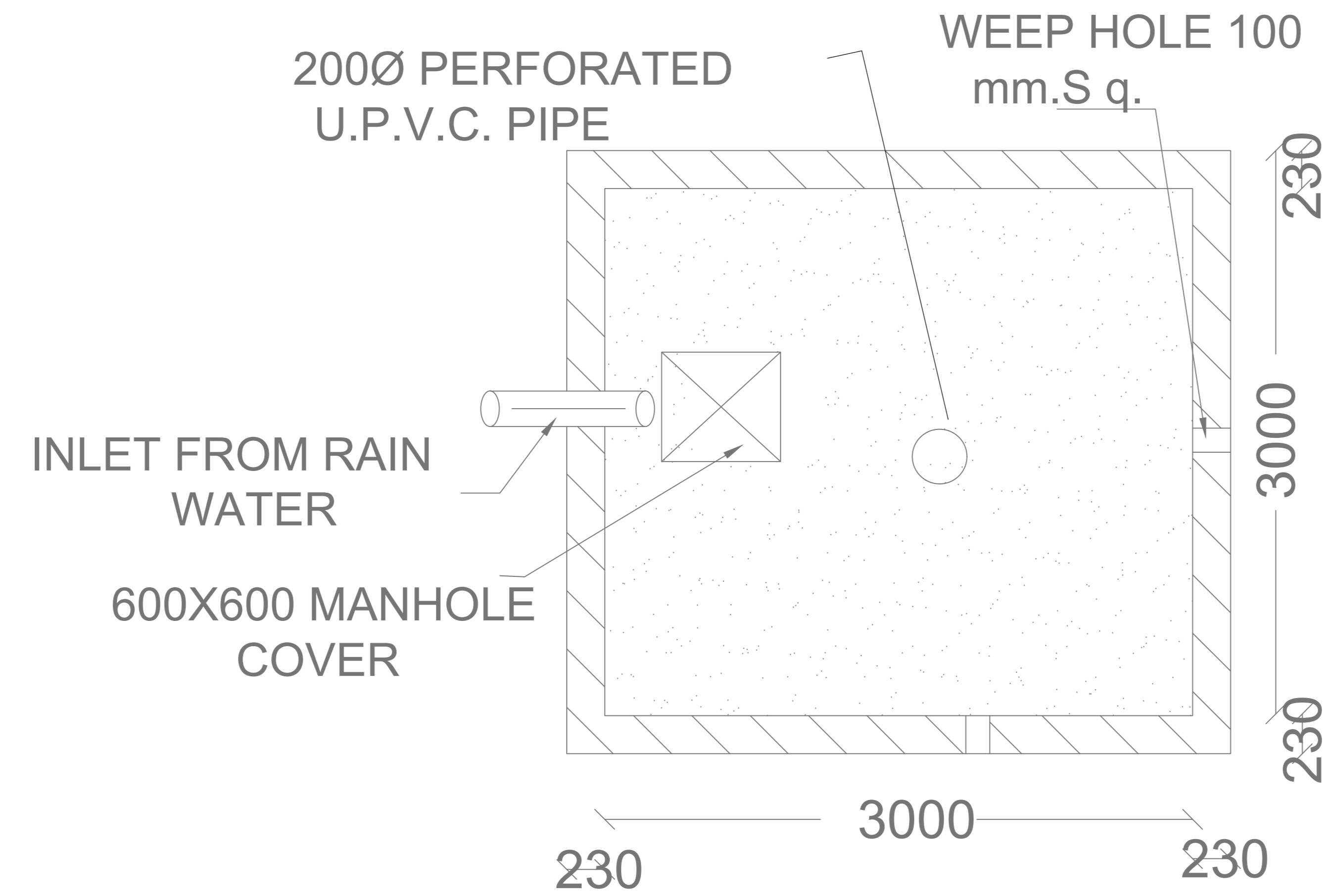
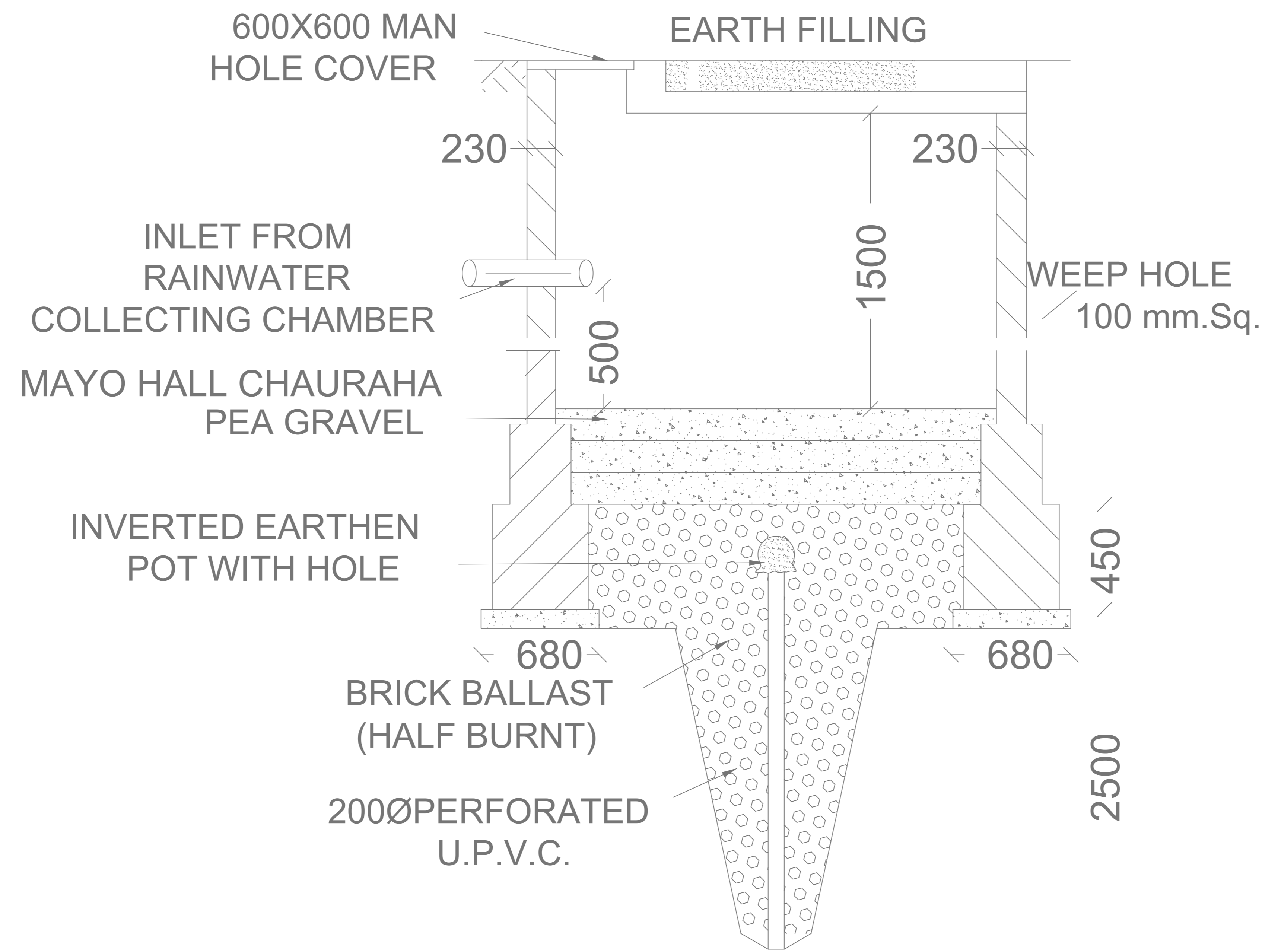

# RAIN WATER HARVESTING TANK

(NOT TO SCALE)  
(6.0 MT. DEEP)

Plot No.	Pack-Bldg	Along Road	Front		Side1		Side2		Rear		Coverage	FSI Area
			Reqt	Prop	Reqt	Prop	Reqt	Prop	Reqt	Prop		
01		12.00 M WIDE ROAD	4.50	-	-	-	-	-	4.50	-	0.00	0.00
01		9.00 M WIDE ROAD	4.50	-	-	-	-	-	-	-	0.00	0.00
02		9.00 M WIDE ROAD	3.00	-	-	-	-	-	3.00	-	0.00	0.00
03		9.00 M WIDE ROAD	3.00	-	-	-	-	-	3.00	-	0.00	0.00
04		9.00 M WIDE ROAD	3.00	-	-	-	-	-	3.00	-	0.00	0.00
05		9.00 M WIDE ROAD	4.50	-	-	-	-	-	4.50	-	0.00	0.00
06		9.00 M WIDE ROAD	3.00	-	-	-	-	-	3.00	-	0.00	0.00
06		9.00 M WIDE ROAD	3.00	-	-	-	-	-	-	-	0.00	0.00
07		9.00 M WIDE ROAD	3.00	-	-	-	-	-	3.00	-	0.00	0.00
08		9.00 M WIDE ROAD	3.00	-	-	-	-	-	3.00	-	0.00	0.00
09		9.00 M WIDE ROAD	3.00	-	-	-	-	-	3.00	-	0.00	0.00
10		9.00 M WIDE ROAD	3.00	-	-	-	-	-	3.00	-	0.00	0.00
11		12.00 M WIDE ROAD	3.00	-	-	-	-	-	3.00	-	0.00	0.00
11		9.00 M WIDE ROAD	3.00	-	-	-	-	-	-	-	0.00	0.00
12		12.00 M WIDE ROAD	3.00	-	-	-	-	-	3.00	-	0.00	0.00
12		9.00 M WIDE ROAD	3.00	-	-	-	-	-	-	-	0.00	0.00
13		9.00 M WIDE ROAD	3.00	-	-	-	-	-	3.00	-	0.00	0.00
14		9.00 M WIDE ROAD	3.00	-	-	-	-	-	3.00	-	0.00	0.00
15		9.00 M WIDE ROAD	3.00	-	-	-	-	-	3.00	-	0.00	0.00
16		9.00 M WIDE ROAD	3.00	-	-	-	-	-	3.00	-	0.00	0.00
17		9.00 M WIDE ROAD	3.00	-	-	-	-	-	3.00	-	0.00	0.00
17		7.50 M WIDE ROAD	3.00	-	-	-	-	-	-	-	0.00	0.00
18		9.00 M WIDE ROAD	3.00	-	-	-	-	-	3.00	-	0.00	0.00
18		7.50 M WIDE ROAD	3.00	-	-	-	-	-	-	-	0.00	0.00
19		9.00 M WIDE ROAD	3.00	-	-	-	-	-	3.00	-	0.00	0.00
20		9.00 M WIDE ROAD	3.00	-	-	-	-	-	3.00	-	0.00	0.00
21		9.00 M WIDE ROAD	3.00	-	-	-	-	-	3.00	-	0.00	0.00
22		9.00 M WIDE ROAD	3.00	-	-	-	-	-	3.00	-	0.00	0.00
23		9.00 M WIDE ROAD	3.00	-	-	-	-	-	3.00	-	0.00	0.00
24		12.00 M WIDE ROAD	3.00	-	-	-	-	-	3.00	-	0.00	0.00
24		9.00 M WIDE ROAD	3.00	-	-	-	-	-	-	-	0.00	0.00
25		12.00 M WIDE ROAD	3.00	-	-	-	-	-	3.00	-	0.00	0.00
25		9.00 M WIDE ROAD	3.00	-	-	-	-	-	-	-	0.00	0.00
26		9.00 M WIDE ROAD	3.00	-	-	-	-	-	3.00	-	0.00	0.00
27		9.00 M WIDE ROAD	3.00	-	-	-	-	-	3.00	-	0.00	0.00
28		9.00 M WIDE ROAD	3.00	-	-	-	-	-	3.00	-	0.00	0.00
29		9.00 M WIDE ROAD	3.00	-	-	-	-	-	3.00	-	0.00	0.00
30		9.00 M WIDE ROAD	3.00	-	-	-	-	-	3.00	-	0.00	0.00
31		9.00 M WIDE ROAD	3.00	-	-	-	-	-	3.00	-	0.00	0.00
31		9.00 M WIDE ROAD	3.00	-	-	-	-	-	-	-	0.00	0.00
31		7.50 M WIDE ROAD	3.00	-	-	-	-	-	-	-	0.00	0.00
32		12.00 M WIDE ROAD	3.00	-	-	-	-	-	3.00	-	0.00	0.00
33		12.00 M WIDE ROAD	2.00	-	-	-	-	-	2.00	-	0.00	0.00
33		9.00 M WIDE ROAD	2.00	-	-	-	-	-	-	-	0.00	0.00
34		9.00 M WIDE ROAD	2.00	-	-	-	-	-	2.00	-	0.00	0.00
35		9.00 M WIDE ROAD	2.00	-	-	-	-	-	2.00	-	0.00	0.00
36		9.00 M WIDE ROAD	2.00	-	-	-	-	-	2.00	-	0.00	0.00
37		9.00 M WIDE ROAD	2.00	-	-	-	-	-	2.00	-	0.00	0.00
38		9.00 M WIDE ROAD	2.00	-	-	-	-	-	2.00	-	0.00	0.00
39		9.00 M WIDE ROAD	2.00	-	-	-	-	-	2.00	-	0.00	0.00
40		9.00 M WIDE ROAD	2.00	-	-	-	-	-	2.00	-	0.00	0.00
41		9.00 M WIDE ROAD	3.00	-	-	-	-	-	3.00	-	0.00	0.00
41		9.00 M WIDE ROAD	3.00	-	-	-	-	-	-	-	0.00	0.00
42		9.00 M WIDE ROAD	1.50	-	-	-	-	-	1.50	-	0.00	0.00
42		7.50 M WIDE ROAD	1.50	-	-	-	-	-	-	-	0.00	0.00
42		9.00 M WIDE ROAD	1.50	-	-	-	-	-	-	-	0.00	0.00
43		9.00 M WIDE ROAD	1.50	-	-	-	-	-	1.50	-	0.00	0.00
44		9.00 M WIDE ROAD	1.50	-	-	-	-	-	1.50	-	0.00	0.00
45		9.00 M WIDE ROAD	1.50	-	-	-	-	-	1.50	-	0.00	0.00
46		9.00 M WIDE ROAD	2.00	-	-	-	-	-	2.00	-	0.00	0.00
47		7.50 M WIDE ROAD	1.50	-	-	-	-	-	1.50	-	0.00	0.00
48		9.00 M WIDE ROAD	1.50	-	-	-	-	-	1.50	-	0.00	0.00
48		7.50 M WIDE ROAD	1.50	-	-	-	-	-	-	-	0.00	0.00
49		9.00 M WIDE ROAD	1.50	-	-	-	-	-	1.50	-	0.00	0.00

OWNER'S NAME AND SIGNATURE  
 Jaysukh Parekh arpanamishra@gmail.com:7570003560  
 Hasrnuh Parekh arpanamishra@gmail.com:7570003560  
 Mehul Jaysukh Parekh arpanamishra@gmail.com:7570003560  
 Nikhil Parekh arpanamishra@gmail.com:7570003560

ARCHENGE'S NAME AND SIGNATURE  
 PAWAN MISHRA  
 CA0434606

Lucknow Development Authority

Building Plan Application Number  
 LDALD21-220748  
 Sanctioned On  
 01 Nov 2021  
 Valid Till  
 07 Dec 2026

Approved By  
 Vice Chairman (Vice Chairman)  
 Lakshman Singh (Junior engineer)  
 Nagendra Singh (Assistant Engineer)  
 Bhupendra Veer Singh (Executive engineer)  
 Nitin Mital (Chief Town Planner)

Pawan kumar Gangwar (Secretary)  
 Vice Chairman (Vice Chairman)

Note: - 1) This drawing is prepared as per the current prevailing Building Bye Laws.  
 2) If Map sanctioned is used for purpose anything other than stated in application will lead to rejection of Map.  
 ISO\_A0\_(841.00\_x\_1189.00\_MM)

Total Plot Area: -	16345.44	Total FAR Area: -	0.00
Total Coverage Area: -	0.00	Total BUA Area: -	0.00



STIE PLAN  
SCALE = 1:100

**REFERENCE -:**

- DRAIN —————
- WATER LINE — x — x — x — x — x —
- ELE.LINE — — — — —
- TREE
- SEWAR LINE — M.H — M.H —
- RAIN WATER HARVESTING ——— R.W.H

LANDSCAPE AND SERCICE PLAN  
SCALE = 1:100

OWNER'S NAME AND SIGNATURE  
Jaysukh Parekh, Hasamukh Parekh, Mehul Jaysukh Parekh, Nikhil Parekh

ARCHITECT'S NAME AND SIGNATURE  
PAWAN MISHRA  
CA04034606

Lucknow Development Authority



Building Plan Application Number  
LDALD21-220748

Sanctioned On  
01 Nov 2021

Valid Till  
07 Dec 2026

Approved By  
Vice Chairman (Vice Chairman)

Examined By  
Lakshman Singh (Junior engineer)

Nagendra Singh (Assistant Engineer)

Bhupendra Veer Singh (Executive engineer)

Nitin Mital (Chief Town Planner)

Pawan kumar Gangwar (Secretary)

Vice Chairman (Vice Chairman)

Note: - 1) This drawing is prepared as per the current prevailing Building Bye Laws.  
2) If Map sanctioned is used for purpose anything other than stated in application will lead to rejection of Map.

Total Plot Area: -	16345.44	Total FAR Area: -	0.00
Total Coverage Area: -	0.00	Total BUA Area: -	0.00