

**Amit Varma**  
Digitally signed by Amit Varma  
Date: 2026.01.03 23:29:02 +05'30'

**LAL SINGH**  
Digitally signed by LAL SINGH  
Date: 2026.01.06 12:46:33 +05'30'

SANCTION AREA				
TOTAL PLOT AREA	=	4800.000 SQ.M		
PERMISSIBLE GROUND COVERAGE @ 40%	=	1920.000 SQ.M		
PERMISSIBLE F.A.R @ 4.0	=	19200.000 SQ.M		
PROPOSED GROUND COVERAGE	=	1919.810 SQ.M		
PROPOSED F.A.R	=	19199.969 SQ.M		

S.NO.	FLOORS	FAR AREA	AREA UNDER 15% SERVICE	NON.FAR AREA	TOTAL BUILT UP AREA
1	BASEMENT FLOOR				3391.500 SQ.M
2	LOWER GROUND FLOOR	299.293	216.896	2875.311	3391.500 SQ.M
3	GROUND FLOOR	1865.632	54.179		1919.810 SQ.M
4	1st FLOOR	1747.439	128.561		1876.000 SQ.M
5	2nd FLOOR	1735.374	159.436		1894.810 SQ.M
6	3rd FLOOR	1735.374	159.436		1894.810 SQ.M
7	4th FLOOR			1864.960	1864.960 SQ.M
8	5th FLOOR			1864.960	1864.960 SQ.M
9	6th FLOOR			1864.960	1864.960 SQ.M
10	7th FLOOR	1103.250	170.928		1274.178 SQ.M
11	FLOOR SERVICE FLOOR-1			1186.375	1186.375 SQ.M
12	8th FLOOR	1011.105	94.485		1105.590 SQ.M
13	9th FLOOR	1001.058	94.485		1095.543 SQ.M
14	10th FLOOR	1011.105	94.485		1105.590 SQ.M
15	FLOOR SERVICE FLOOR-2			1105.590	1105.590 SQ.M
16	11th FLOOR	1011.105	94.485		1105.590 SQ.M
17	12th FLOOR	1001.058	94.485		1095.543 SQ.M
18	13th FLOOR	1011.105	94.485		1105.590 SQ.M
19	14th FLOOR	1011.105	94.485		1105.590 SQ.M
20	FLOOR SERVICE FLOOR			1105.590	1105.590 SQ.M
21	15th FLOOR	1011.105	94.485		1105.590 SQ.M
22	16th FLOOR	1001.058	94.485		1095.543 SQ.M
23	17th FLOOR	1011.105	94.485		1105.590 SQ.M
24	18th FLOOR	632.698	164.289		796.987 SQ.M
25	MUMTY M.ROOM		96.990		96.990 SQ.M
26	O.H.WATER TANK		48.495		48.495 SQ.M
	<b>TOTAL</b>	<b>19199.969</b>	<b>2616.750</b>	<b>14786.557</b>	<b>36603.275 SQ.M</b>

**TOTAL FESS AREA = 36603.275. SQ.M**

PROPOSED GREEN AREA CALCULATION						
S. NO.	DIM(m)	X	DIM(m)	FEC.	NOS.	AREA(SQ.M.)
G01	2.950	X	44.400	1	1	130.980
G02	5.300	X	6.740	1	1	37.070
G03	1.350	X	6.500	1	1	8.775
G04	1.100	X	6.500	1	1	7.150
G05	25.100	X	1.800	1	1	45.180
G06		AS/PLINE			1	1.930
G07	31.850	X	1.800	1	1	57.330
G08	3.000	X	3.000	0.5	1	4.500
G09		AS/PLINE			1	2.570
G10	0.250	X	1.185	1	1	0.296
G11	3.250	X	20.100	1	1	65.325
G12	1.850	X	2.950	1	1	5.458
G13	1.850	X	2.950	1	1	5.458
G14	2.050	X	4.700	1	1	9.635
G15	3.000	X	3.050	0.5	1	4.575
G16	0.250	X	3.050	1	1	0.763
G17		AS/PLINE			1	2.640
G18	6.450	X	0.550	1	1	3.548
G19	41.000	X	8.200	1	1	336.200
	<b>TOTAL GREEN AREA (G)</b>					<b>729.38</b>

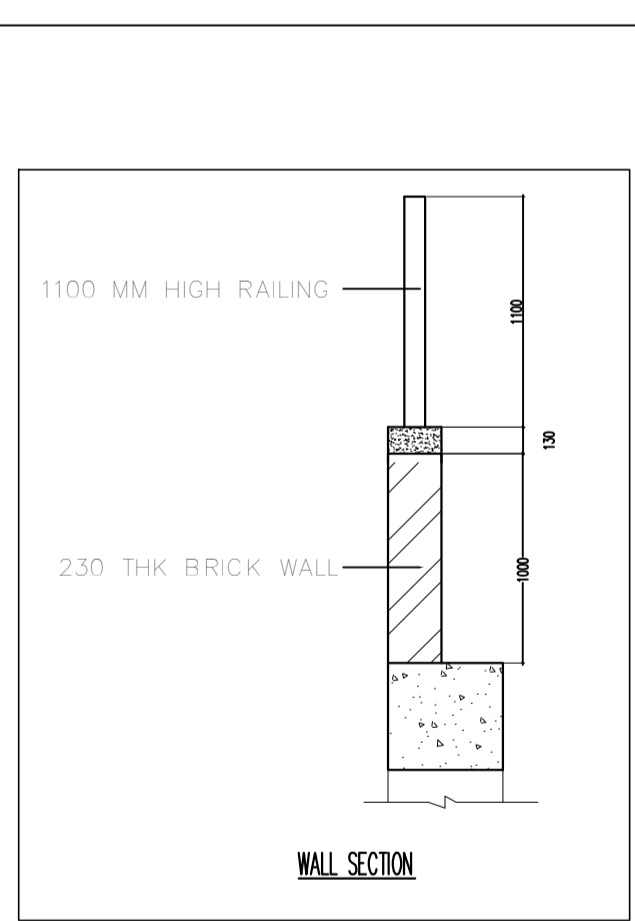
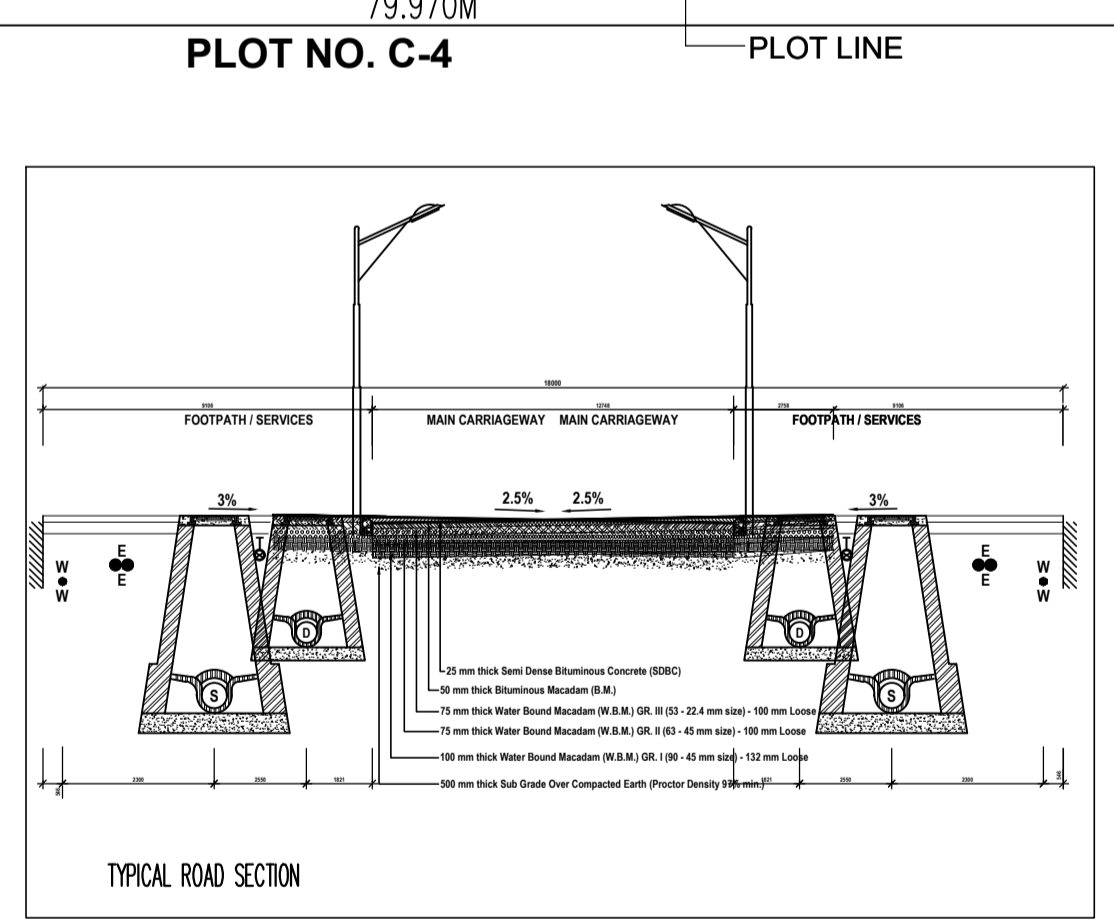
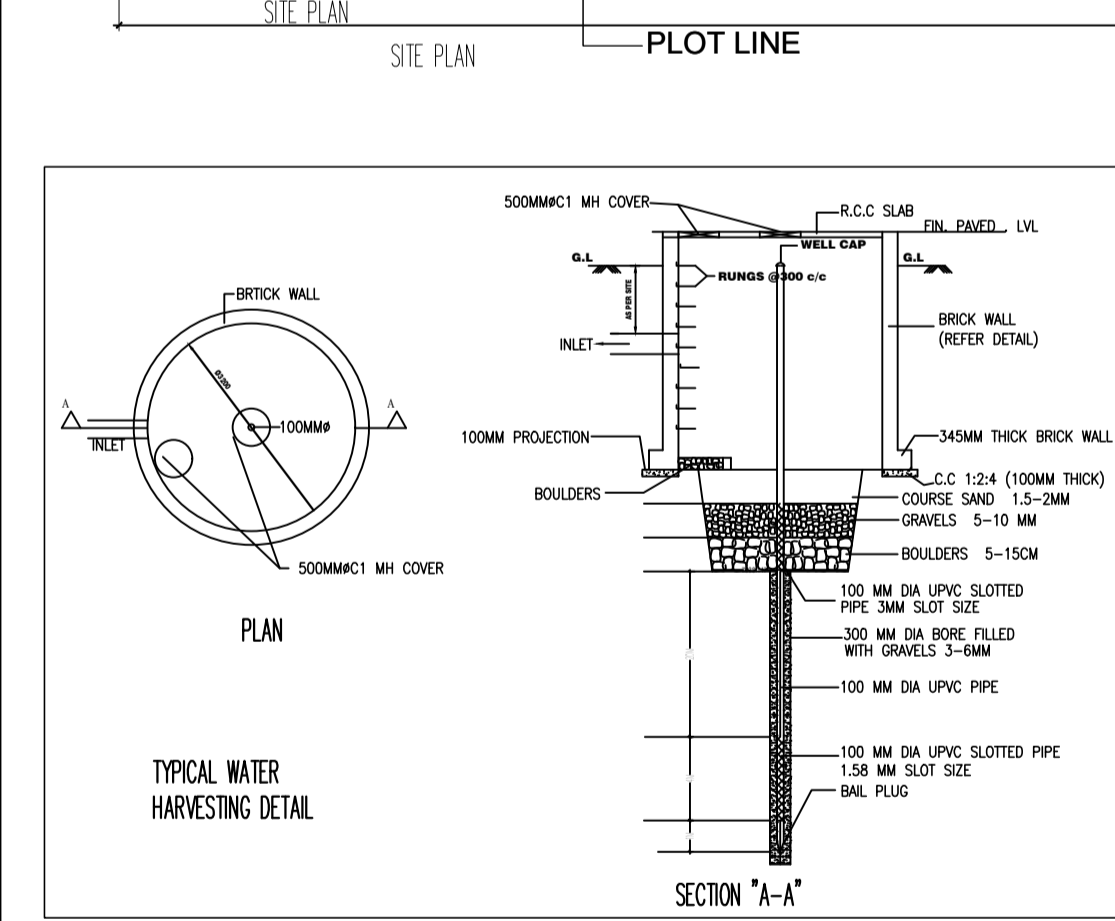

SCHEDULE OF OPENINGS				
TYPE	WIDTH	HEIGHT	SILL HT.	LINTEL
D1	750	2100	-	2100
D2	1000	2100	-	2100
D3	1200	2100	-	2100
D4	1050	2100	-	2100
FD01	2150	2100	-	2100
FD02	1500	2100	-	2100
FD03	1700	2100	-	2100
RS	3000	2400	-	2700
W1	1700	2100	900	3000
W2	2058	2100	900	300
W3	2300	2100	900	300
W4	2725	2100	900	300
W5	3300	2100	900	300
DW1	3500	2100	-	-
SD1	2400	2100	-	-

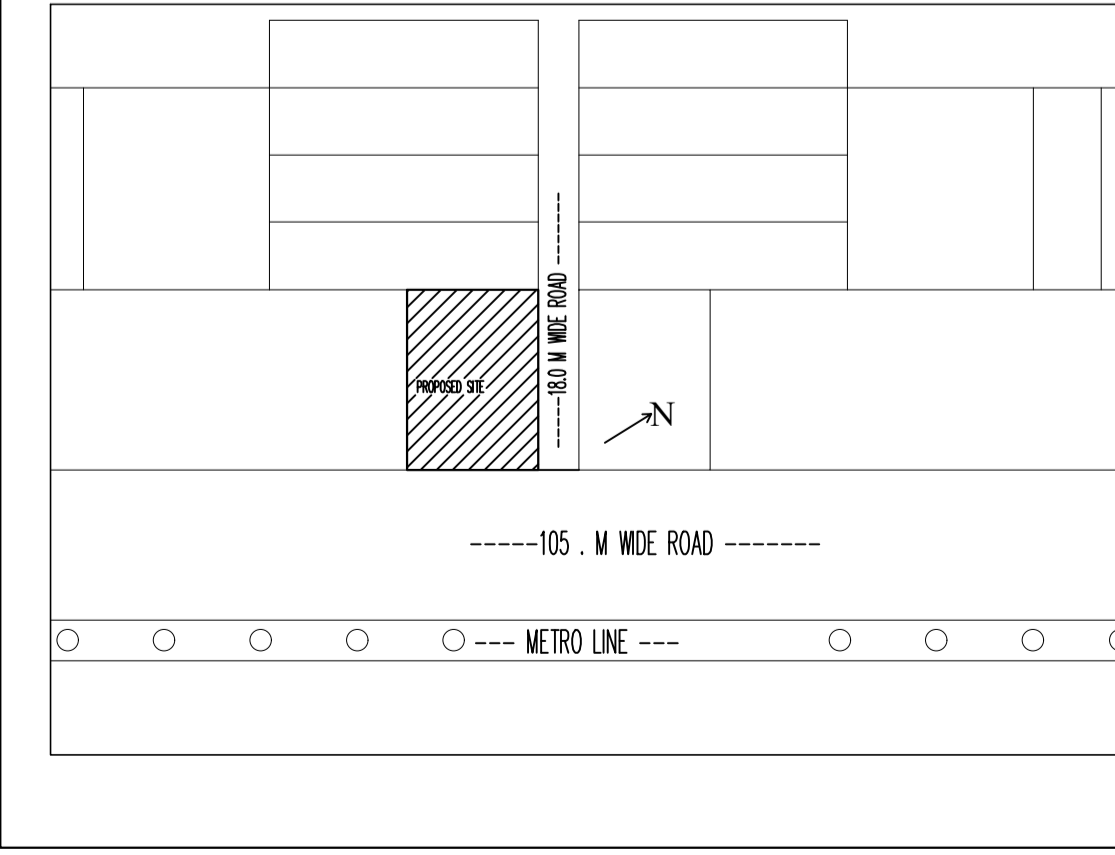

GREEN AREA DETAIL :-	
<b>GREEN AREA :-</b>	
GREEN AREA @25% OF OPEN AREA	
OPEN AREA = PLOT AREA - GROUND COVERAGE	
OPEN AREA = (4800.00 - 1915.21)	
= 2884.79 SQ.M.	
GREEN AREA REQUIRED 25% OF 2884.79 = 721.19 SQ.M.	
GREEN AREA PROVIDED PLAN = 729.38 SQ.M.	

PARKING DETAIL :-	
<b>ECS REQUIRED :-</b>	
PARKING REQUIREMENT FOR COMMERCIAL AREA	
1 EQ.CAR SPACE PER 50 SQ.MT. OF FAR AREA	
TOTAL FAR AREA ALL FLOOR= 19200.00 SQ.MT	
PARKING REQUIRED = $\frac{19200 \times 1}{50}$ = 384 ECS	
NET PARKING REQUIRED = 384 ECS	
<b>ECS PROVIDED :-</b>	
MECHANICAL PARKING AT 1ST.BASEMENT = 133 ECS	
MECHANICAL PARKING AT LOWER GR.FL. = 130 ECS	
PARKING AT 4th+5th+6th FLOOR = 158 ECS	
NET PARKING PROVIDED = 421 ECS	

NO. OF TREES REQUIRED @ 1 TREE PER 100 SQ M OF OPEN AREA			
		$\frac{2884.79}{100} = 28.84$	∴ 29 TREE
NO. OF TREES PROVIDED			
		29 (EVER GREEN)	
NAMES		NO.s	
1	CASSIA FISTULA SM C/C	12	
2	DELONIX REGIA	20	
	<b>TOTAL</b>	<b>32</b>	

TITLE SITE PLAN & AREA CALCULATION	
PROJECT:- PROPOSED BUILDING PLAN OF COMMERCIAL AT PLOT NO.-: C-5, SECTOR DELTA-I, GREATER NOIDA M/S KAVERI ELITE INFRA DEVELOPERS PVT. LTD	
OWNER 'S SIGNATURE	ARCHITECT 'S SIGNATURE
<b>Girish Kumar Goel</b> Digitally signed by Girish Kumar Goel Date: 2026.01.03 22:28:02 +05'30'	<b>MAHTA B ALAM SAIFI</b> Digitally signed by MAHTAB ALAM SAIFI Date: 2026.01.03 22:52:24 +05'30'

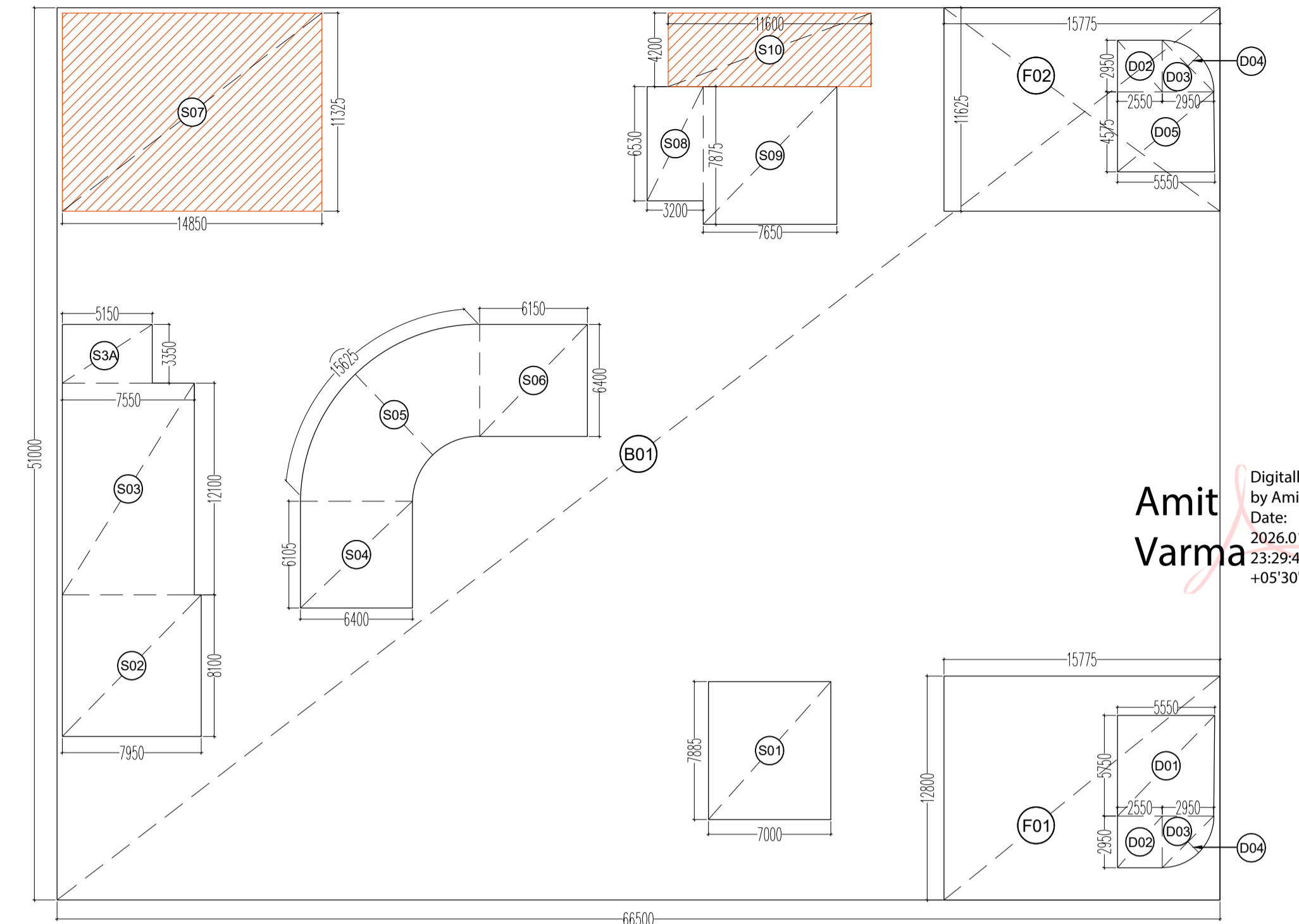
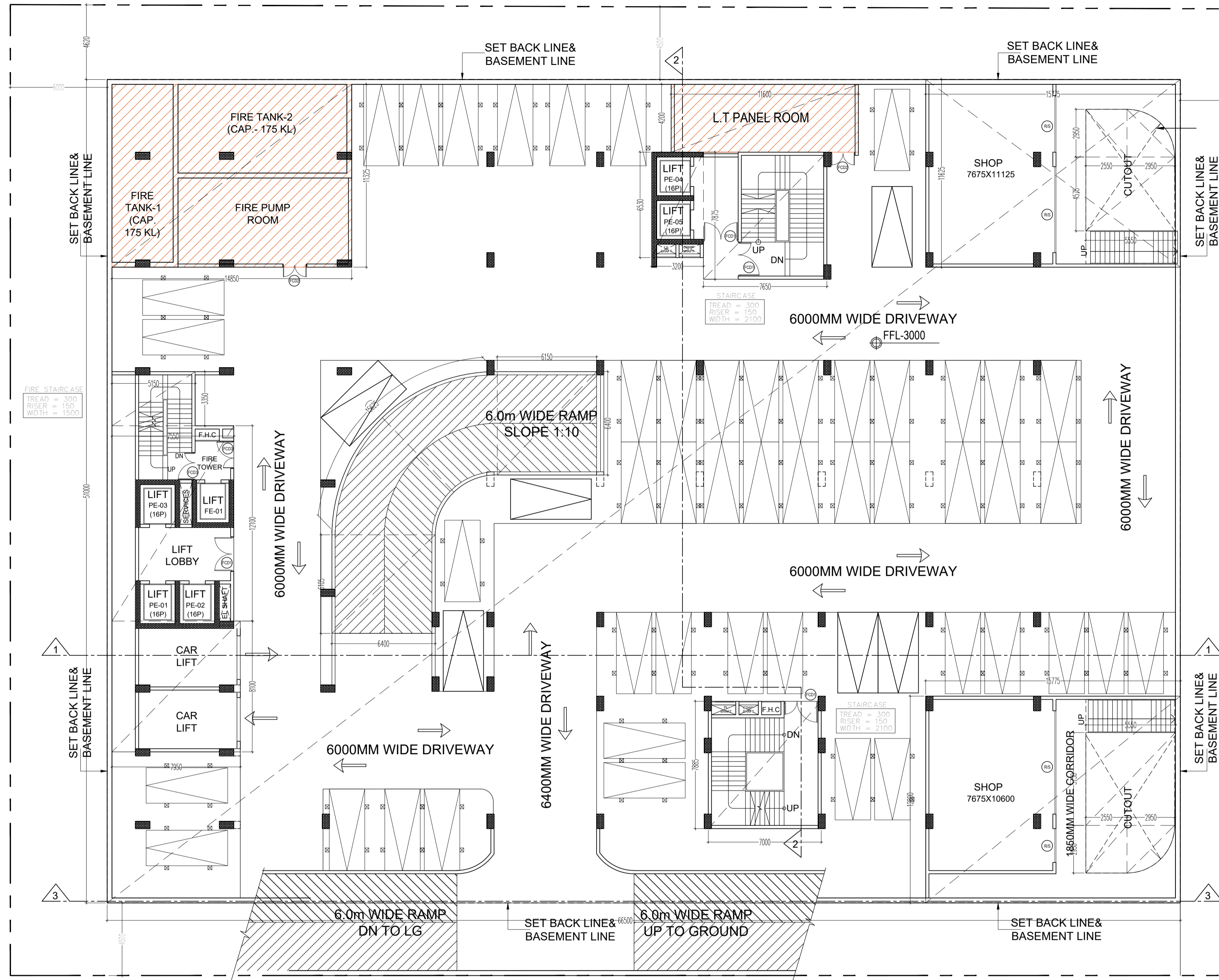

LOWER GROUND FLOOR ENVELOPE PLAN

Amit Varma  
Digitally signed by Amit Varma  
Date: 2026.01.03  
22:29:48  
+05'30'

LOWER GROUND FLOOR AREA CALCULATION						
PARKING AREA = BASEMENT AREA - SERVICE AREA - FAR						
BASEMENT AREA						
S. NO.	DIM(m)	X	DIM(m)	FEC.	NOS.	AREA(SQM.)
B01	66.500	X	51.000	1	1	3391.500
<b>TOTAL LOWER GROUND FLOOR AREA (A)</b>						<b>3391.500</b>
DEDUCTION AREA						
S01	7.000	X	7.885	1	1	55.195
S02	7.950	X	8.100	1	1	64.395
S03	7.550	X	12.100	1	1	91.355
S3A	5.150	X	3.350	1	1	17.253
S04	6.400	X	6.105	1	1	39.072
S05	AS/PLINE			1	1	70.070
S06	6.150	X	6.400	1	1	39.360
S07	14.850	X	11.325	1	1	168.176
S08	3.200	X	6.530	1	1	20.896
S09	7.650	X	7.875	1	1	60.244
S10	11.600	X	4.200	1	1	48.720
<b>TOTAL SERVICES AREA (B)</b>						<b>674.736</b>
FAR AT LOWER GROUND FLOOR						
FAR AREA = ADDITION AREA - DEDUCTION AREA						
ADDITION AREA						
F01	15.775	X	12.800	1	1	201.920
F02	15.775	X	11.625	1	1	183.384
<b>TOTAL ADDITION AREA (C)</b>						<b>385.304</b>
DEDUCTION AREA						
D01	5.550	X	5.750	1	1	31.913
D02	2.550	X	2.950	1	2	15.045
D03	2.950	X	2.950	0.5	2	8.703
D04	AS/PLINE			1	2	4.960
D05	5.550	X	4.575	1	1	25.391
<b>TOTAL DEDUCTION AREA (D)</b>						<b>86.011</b>
<b>FAR AREA AT LOWER GROUND FLOOR (E) = (C-D)</b>						<b>299.293</b>
<b>TOTAL PARKING AREA AT LOWER GROUND FLOOR = (A-B-C)</b>						<b>2331.460</b>
<b>PARKING AT LOWER GROUND FLOOR (2331.46/18)</b>						<b>130</b>
<b>PARKING PROVIDED AT LOWER GROUND FL. (MECHANICAL 65X2)</b>						<b>130 CAR</b>
SERVICES AREA AT LOWER GROUND FLOOR						
S07	14.850	X	11.325	1	1	168.176
S10	11.600	X	4.200	1	1	48.720
<b>SERVICES AREA AT LOWER GROUND FLOOR</b>						<b>216.896</b>
<b>NON FAR AREA AT LOWER GROUND FLOOR=( A-E)</b>						<b>2875.311</b>

SCHEDULE OF OPENINGS				
TYPE	WIDTH	HEIGHT	SILL HT.	LINTEL
D1	750	2100	-	2100
D2	1000	2100	-	2100
D3	1200	2100	-	2100
D4	1050	2100	-	2100
FCD1	2150	2100	-	2100
FCD2	1500	2100	-	2100
FCD3	1700	2100	-	2100
RS	3000	2400	-	2700
W1	1700	2100	900	3000
W2	2058	2100	900	300
W3	2300	2100	900	300
W4	2725	2100	900	300
W5	3300	2100	900	300
DW1	3500	2100	-	-
SD1	2400	2100	-	-

LOWER GROUND FLOOR PLAN

TITLE LOWER GROUND FLOOR PLAN

PROJECT:-  
PROPOSED BUILDING PLAN OF COMMERCIAL AT PLOT NO.- C-5 , SECTOR DELTA-I, GREATER NOIDA  
M/S KAVERI ELITE INFRA DEVELOPERS PVT. LTD

OWNER 'S SIGNATURE ARCHITECT 'S SIGNATURE

Digitally signed by  
**Girish Kumar Goel**  
Date: 2026.01.03  
22:29:17  
+05'30'

Digitally signed by  
**MAHTAB ALAM SAIFI**  
Date: 2026.01.03  
22:53:44  
+05'30'

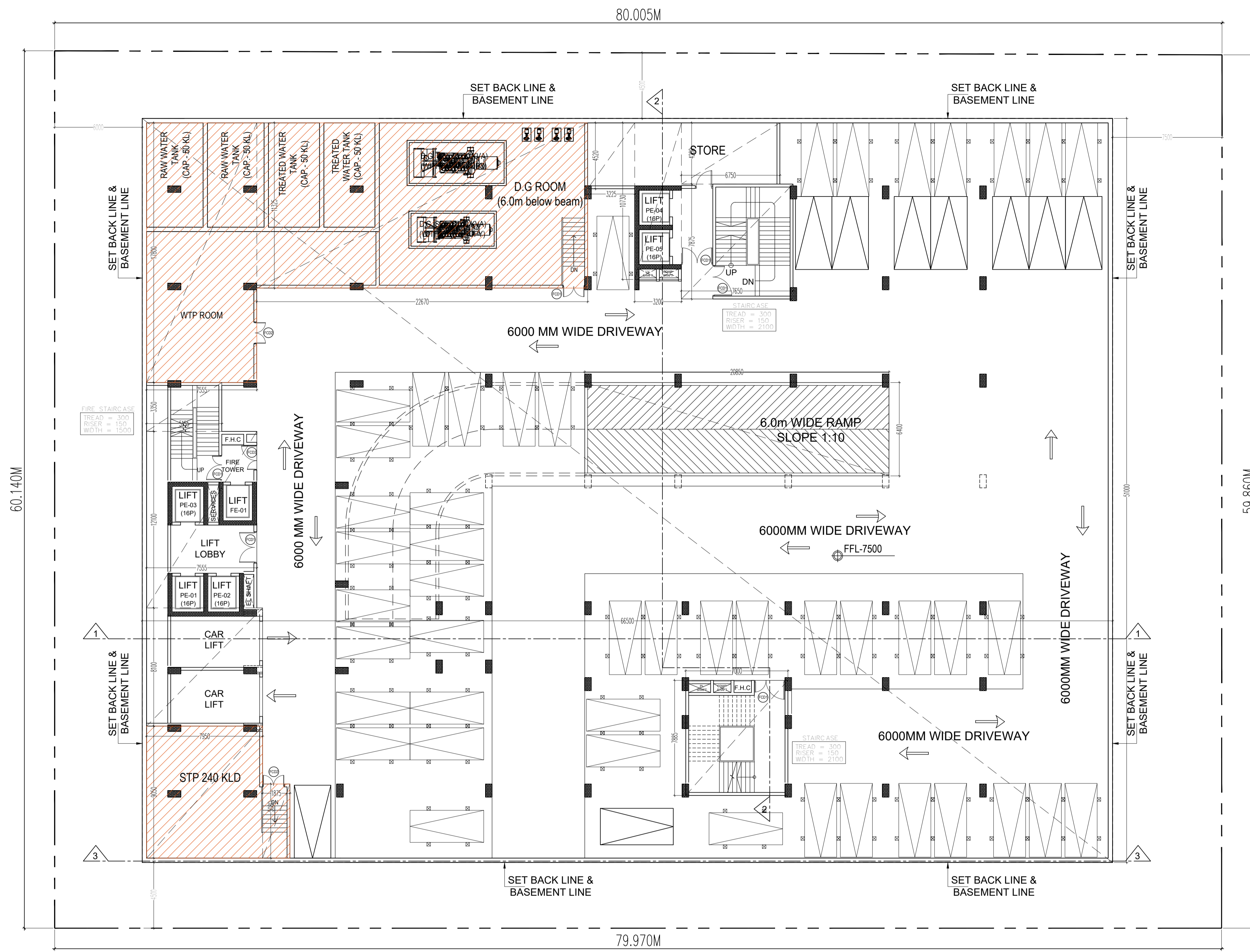

1st BASEMENT FLOOR PLAN

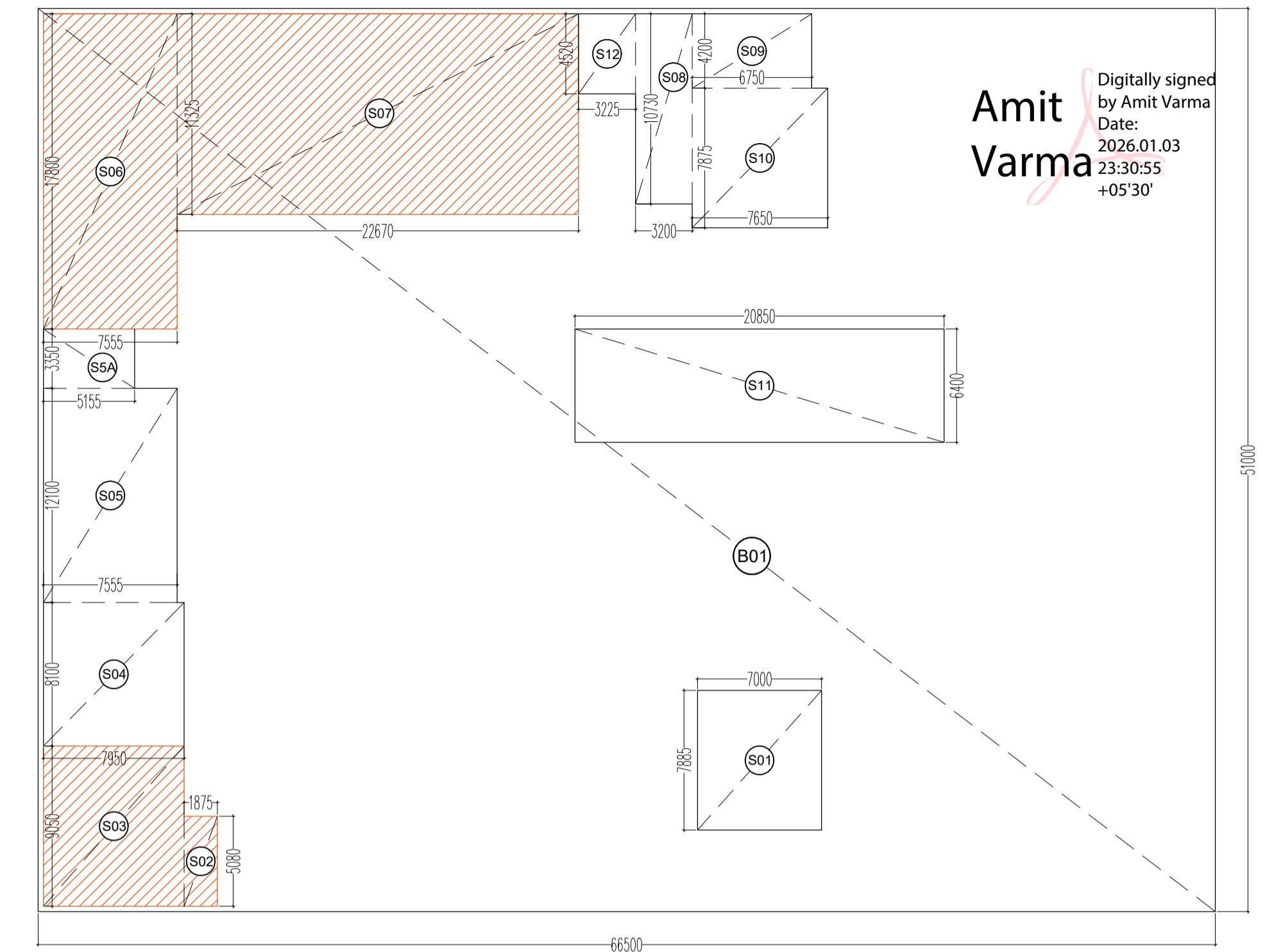

1st. BASEMENT FLOOR ENVELOPE PLAN

1ST BASEMENT FLOOR AREA CALCULATION						
PARKING AREA = BASEMENT AREA - SERVICE AREA						
BASEMENT AREA						
S. NO.	DIM(m)	X	DIM(m)	FEC.	NOS.	AREA(SQM.)
B01	66.500	X	51.000	1	1	3391.500
<b>TOTAL BASEMENT AREA (A)</b>						<b>3391.500</b>
DEDUCTION AREA						
S01	7.000	X	7.885	1	1	55.195
S02	1.875	X	5.080	1	1	9.525
S03	7.950	X	9.050	1	1	71.948
S04	7.950	X	8.100	1	1	64.395
S05	7.555	X	12.100	1	1	91.416
SSA	5.155	X	3.350	1	1	17.269
S06	7.555	X	17.800	1	1	134.479
S07	22.670	X	11.325	1	1	256.738
S08	3.200	X	10.730	1	1	34.336
S09	6.750	X	4.200	1	1	28.350
S10	7.650	X	7.875	1	1	60.244
S11	20.850	X	6.400	1	1	133.440
S12	3.225	X	4.520	1	1	14.577
<b>TOTAL SERVICES AREA (B)</b>						<b>971.911</b>
<b>TOTAL PARKING AREA AT 1ST BASEMENT = (A-B)</b>						<b>2419.589</b>
PARKING AT 1ST. BASEMENT (2419.58/18)						134
PARKING PROVIDED AT 1ST. BASEMENT (MECHANICAL 67X2)						134
SERVICES AREA AT 1ST. BASEMENT						
S02	1.875	X	5.080	1	1	9.525
S03	7.950	X	9.050	1	1	71.948
S06	7.555	X	17.800	1	1	134.479
S07	22.670	X	11.325	1	1	256.738
<b>SERVICES AREA AT 1ST. BASEMENT = (S)</b>						<b>472.689</b>
<b>TOTAL NON-FAR AREA (A-S)</b>						<b>2918.811</b>

SCHEDULE OF OPENINGS				
TYPE	WIDTH	HEIGHT	SILL HT.	LINTEL
D1	750	2100	-	2100
D2	1000	2100	-	2100
D3	1200	2100	-	2100
D4	1050	2100	-	2100
FCD1	2150	2100	-	2100
FCD2	1500	2100	-	2100
FCD3	1700	2100	-	2100
RS	3000	2400	-	2700
W1	1700	2100	900	3000
W2	2058	2100	900	300
W3	2300	2100	900	300
W4	2725	2100	900	300
W5	3300	2100	900	300
DW1	3500	2100	-	-
SD1	2400	2100	-	-

TITLE		1st BASEMENT FLOOR PLAN	
PROJECT:- PROPOSED BUILDING PLAN OF COMMERCIAL AT PLOT NO.-: C-5 , SECTOR DELTA-I, GREATER NOIDA M/S KAVERI ELITE INFRA DEVELOPERS PVT. LTD			
OWNER 'S SIGNATURE		ARCHITECT 'S SIGNATURE	
<b>Girish Kumar Goel</b> Digitally signed by Girish Kumar Goel Date: 2026.01.03 22:30:17 +05'30'		<b>MAHTAB ALAM SAIFI</b> Digitally signed by MAHTAB ALAM SAIFI Date: 2026.01.03 23:16:22 +05'30'	

Amit Varma  
Digitally signed by Amit Varma  
Date: 2026.01.03 23:30:55 +05'30'

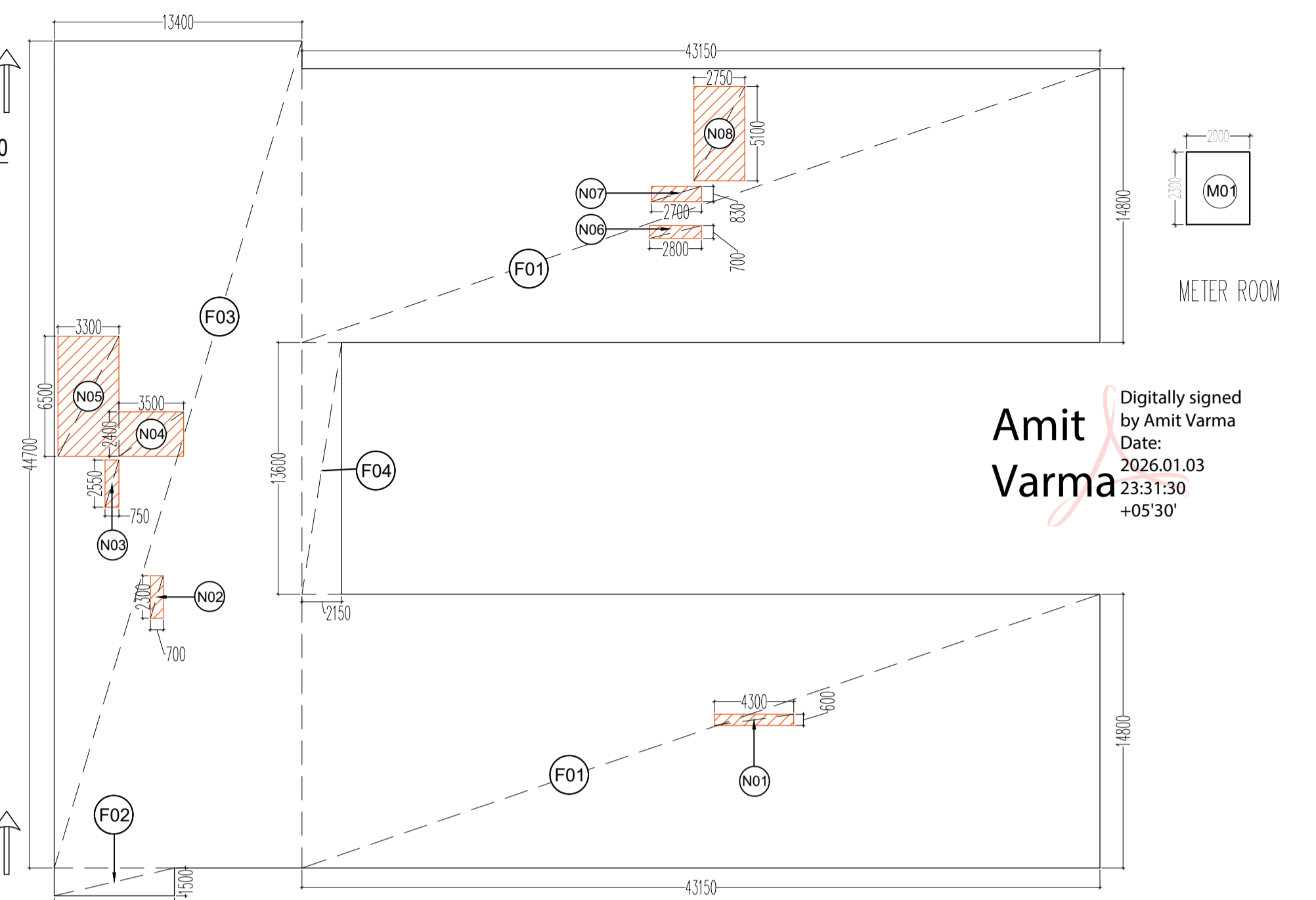
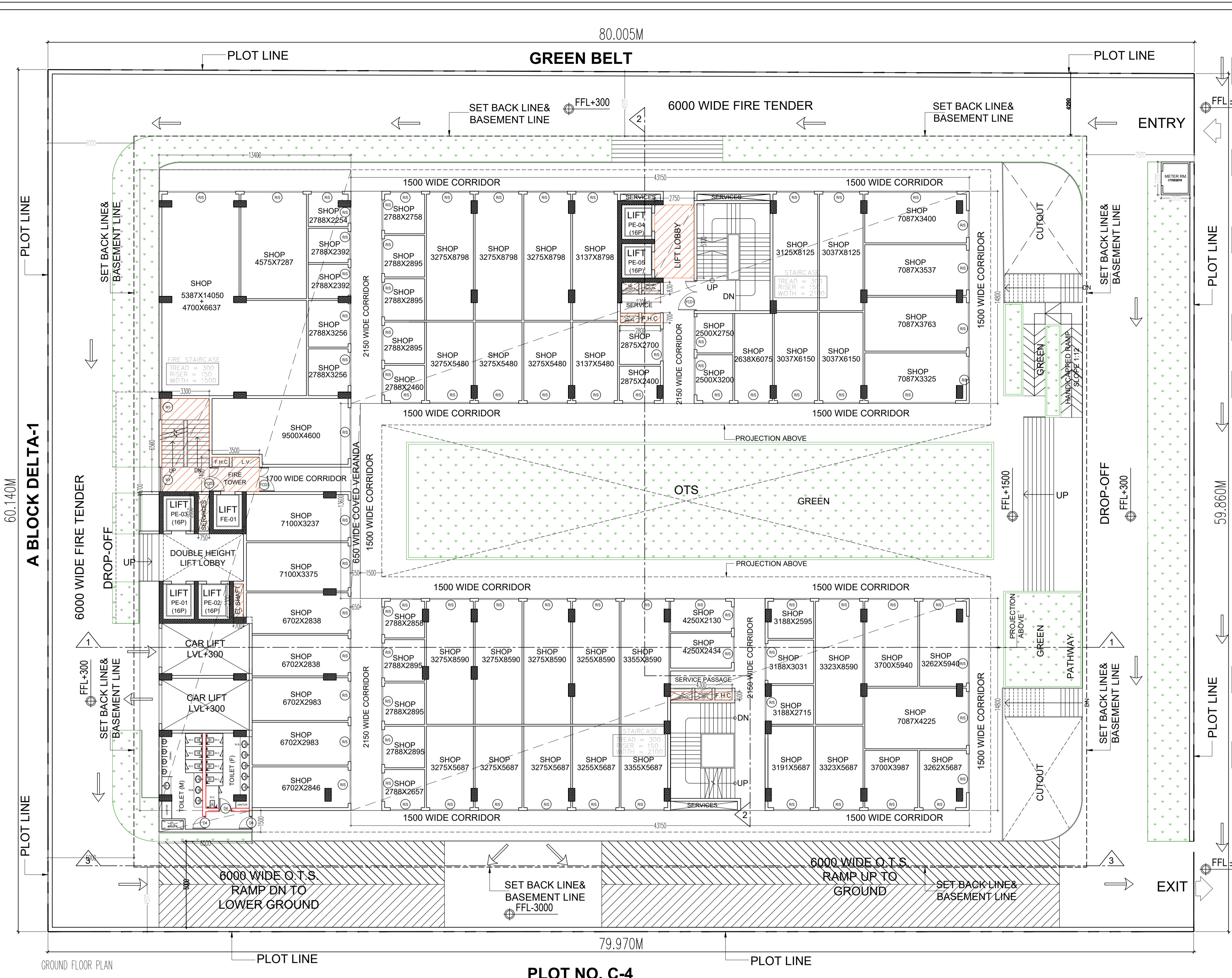

Amit Varma  
Digitally signed by Amit Varma  
Date: 2026.01.03 23:31:30 +05'30'

GROUND FLOOR ENVELOPE PLAN

GROUND FLOOR AREA CALCULATION						
FAR AREA = ADDITION AREA - DEDUCTION AREA						
ADDITION AREA						
S. NO.	DIM(m)	X	DIM(m)	FEC.	NOS.	AREA(SQ.M.)
F01	43.150	X	14.800	1	2	1277.240
F02	6.500	X	1.500	1	1	9.750
F03	13.400	X	44.700	1	1	598.980
F04	0.650	X	13.600	1	1	8.840
<b>TOTAL ADDITION AREA (A)</b>						<b>1894.810</b>
DEDUCTION AREA						
N01	4.300	X	0.600	1	1	2.580
N02	0.700	X	2.300	1	1	1.610
N03	0.750	X	2.550	1	1	1.913
N04	3.500	X	2.400	1	1	8.400
N05	3.300	X	6.500	1	1	21.450
N06	2.800	X	0.700	1	1	1.960
N07	2.700	X	0.830	1	1	2.241
N08	2.750	X	5.100	1	1	14.025
<b>TOTAL DEDUCTION AREA (B)</b>						<b>54.179</b>
<b>FAR AREA AT GROUND FLOOR (C) = (A-B)</b>						<b>1840.632</b>
<b>(M01) METER ROOM (2.0X2.3) (D)</b>						<b>4.600</b>
<b>NET FAR AT GROUND FLOOR (C+D)</b>						<b>1845.232</b>
<b>TOTAL GROUND COVERAGE=A+D</b>						<b>1899.410</b>

SCHEDULE OF OPENINGS				
TYPE	WIDTH	HEIGHT	SILL HT.	LINTEL
D1	750	2100	-	2100
D2	1000	2100	-	2100
D3	1200	2100	-	2100
D4	1050	2100	-	2100
FCD1	2150	2100	-	2100
FCD2	1500	2100	-	2100
FCD3	1700	2100	-	2100
RS	3000	2400	-	2700
W1	1700	2100	900	3000
W2	2058	2100	900	300
W3	2300	2100	900	300
W4	2725	2100	900	300
W5	3300	2100	900	300
DW1	3500	2100	-	-
SD1	2400	2100	-	-

**TITLE** GROUND FLOOR PLAN

**PROJECT:-**  
PROPOSED BUILDING PLAN OF COMMERCIAL AT PLOT NO.- C-5 , SECTOR DELTA-I, GREATER NOIDA M/S KAVERI ELITE INFRA DEVELOPERS PVT. LTD

<b>OWNER 'S SIGNATURE</b>	<b>ARCHITECT 'S SIGNATURE</b>
<p>Digitally signed by Girish Kumar Goel Date: 2026.01.03 22:31:24 +05'30'</p> <p><b>Girish Kumar Goel</b></p>	<p>Digitally signed by MAHTAB ALAM SAIFI Date: 2026.01.03 23:14:41 +05'30'</p> <p><b>MAHTAB ALAM SAIFI</b></p>



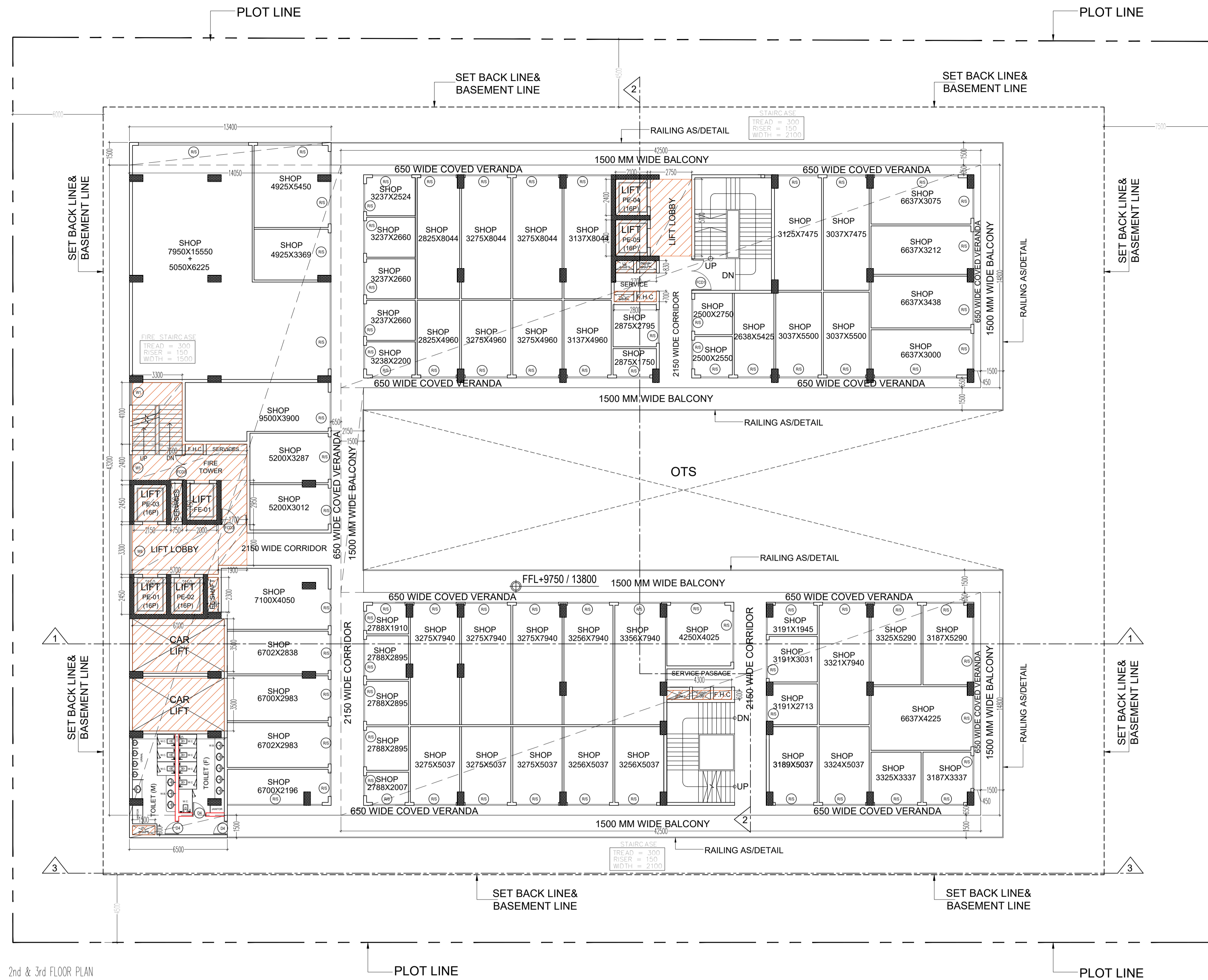

2nd & 3rd FLOOR PLAN

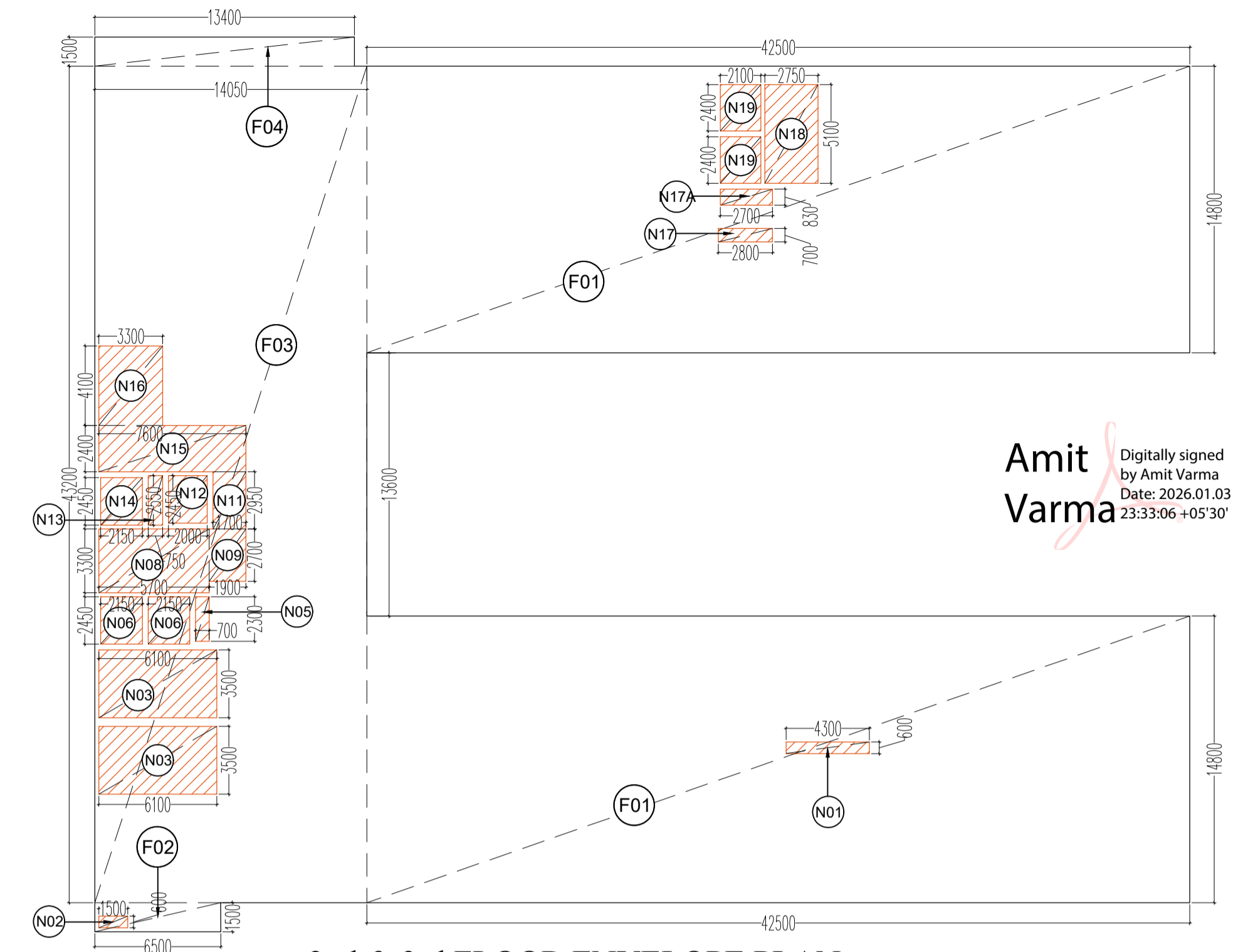

2nd & 3rd FLOOR ENVELOPE PLAN

Amit Varma  
Digitally signed by Amit Varma  
Date: 2026.01.03  
23:33:06 +05'30'

2ND & 3RD FLOOR AREA CALCULATION						
FAR AREA = ADDITION AREA - DEDUCTION AREA						
ADDITION AREA						
S. NO.	DIM(m)	X	DIM(m)	FEC.	NOS.	AREA(SQM.)
F01	42.500	X	14.800	1	2	1258.000
F02	6.500	X	1.500	1	1	9.750
F03	14.050	X	43.200	1	1	606.960
F04	13.400	X	1.500	1	1	20.100
<b>TOTAL ADDITION AREA (A)</b>						<b>1894.810</b>
DEDUCTION AREA						
N01	4.300	X	0.600	1	1	2.580
N02	1.500	X	0.600	1	1	0.900
N03	6.100	X	3.500	1	2	42.700
N05	0.700	X	2.300	1	1	1.610
N06	2.150	X	2.450	1	2	10.535
N08	5.700	X	3.300	1	1	18.810
N09	1.900	X	2.700	1	1	5.130
N11	1.700	X	2.950	1	1	5.015
N12	2.000	X	2.450	1	1	4.900
N13	0.750	X	2.550	1	1	1.913
N14	2.150	X	2.450	1	1	5.268
N15	7.600	X	2.400	1	1	18.240
N16	3.300	X	4.100	1	1	13.530
N17	2.800	X	0.700	1	1	1.960
N17A	2.700	X	0.830	1	1	2.241
N18	2.750	X	5.100	1	1	14.025
N19	2.100	X	2.400	1	2	10.080
<b>TOTAL DEDUCTION AREA (B)</b>						<b>159.436</b>
<b>FAR AREA AT 2ND &amp; 3RD FLOOR (C) = (A-B)</b>						<b>1735.374</b>

SERVICES AREA AT 2ND & 3RD FLOOR						
N01	4.300	X	0.600	1	1	2.580
N02	1.500	X	0.600	1	1	0.900
N03	6.100	X	3.500	1	2	42.700
N05	0.700	X	2.300	1	1	1.610
N06	2.150	X	2.450	1	2	10.535
N08	5.700	X	3.300	1	1	18.810
N09	1.900	X	2.700	1	1	5.130
N11	1.700	X	2.950	1	1	5.015
N12	2.000	X	2.450	1	1	4.900
N13	0.750	X	2.550	1	1	1.913
N14	2.150	X	2.450	1	1	5.268
N15	7.600	X	2.400	1	1	18.240
N16	3.300	X	4.100	1	1	13.530
N17	2.800	X	0.700	1	1	1.960
N17A	2.700	X	0.830	1	1	2.241
N18	2.750	X	5.100	1	1	14.025
N19	2.100	X	2.400	1	2	10.080
<b>TOTAL SERVICES AREA AT 2ND &amp; 3RD FLOOR</b>						<b>159.436</b>

SCHEDULE OF OPENINGS				
TYPE	WIDTH	HEIGHT	SILL HT.	LINTEL
D1	750	2100	-	2100
D2	1000	2100	-	2100
D3	1200	2100	-	2100
D4	1050	2100	-	2100
FCD1	2150	2100	-	2100
FCD2	1500	2100	-	2100
FCD3	1700	2100	-	2100
RS	3000	2400	-	2700
W1	1700	2100	900	3000
W2	2058	2100	900	300
W3	2300	2100	900	300
W4	2725	2100	900	300
W5	3300	2100	900	300
DW1	3500	2100	-	-
SD1	2400	2100	-	-

TITLE 2nd & 3rd FLOOR PLAN (TYPICAL)

PROJECT:- PROPOSED BUILDING PLAN OF COMMERCIAL AT PLOT NO.- C-5 , SECTOR DELTA-I, GREATER NOIDA M/S KAVERI ELITE INFRA DEVELOPERS PVT. LTD

OWNER 'S SIGNATURE ARCHITECT 'S SIGNATURE

**Girish Kumar Goel** Digitally signed by Girish Kumar Goel Date: 2026.01.03 22:33:21 +05'30'

**MAHTAB ALAM SAIFI** Digitally signed by MAHTAB ALAM SAIFI Date: 2026.01.03 23:11:32 +05'30'

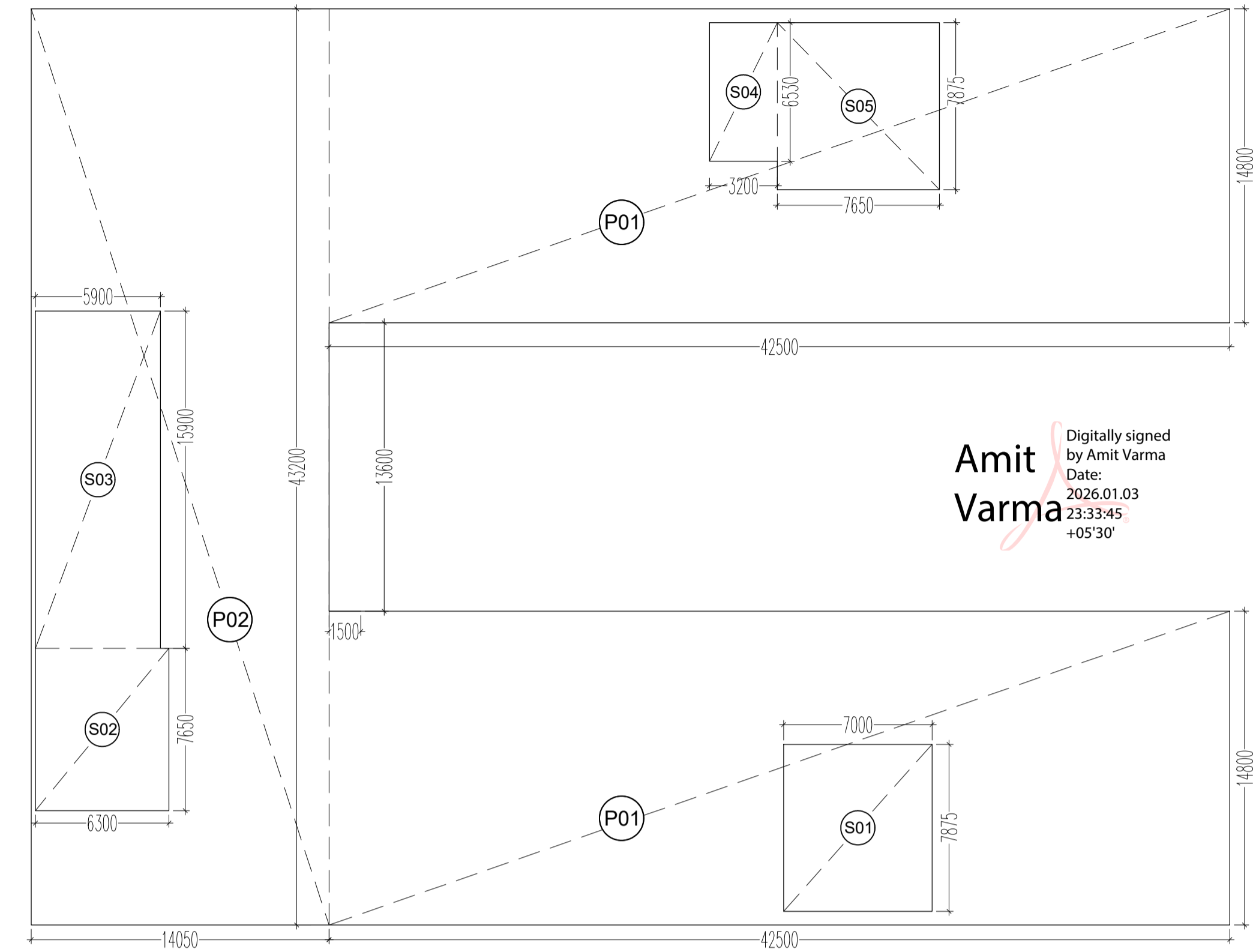
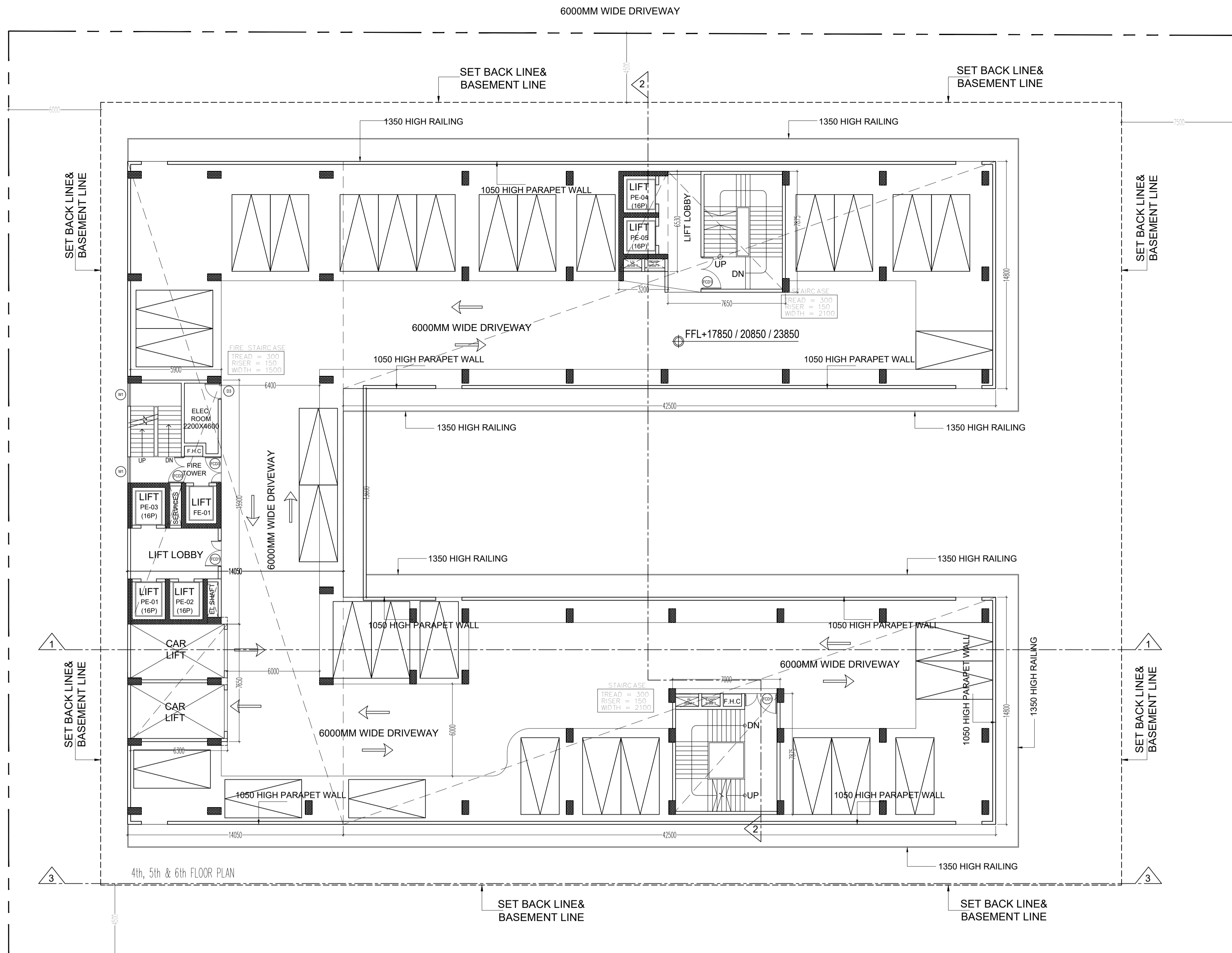

4TH,5TH & 6TH FLOOR ENVELOPE PLAN

Amit Varma  
Digitally signed by Amit Varma  
Date: 2026.01.03 23:33:45 +05'30'

4TH, 5TH & 6TH FLOOR (PARKING) AREA CALCULATION						
PARKING AREA = ADDITION AREA - DEDUCTION AREA						
ADDITION AREA						
S. NO.	DIM(m)	X	DIM(m)	FEC.	NOS.	AREA(SQM.)
P01	42.500	X	14.800	1	2	1258.000
P02	14.050	X	43.200	1	1	606.960
<b>TOTAL ADDITION AREA (A)</b>						<b>1864.960</b>
DEDUCTION AREA						
S01	7.000	X	7.875	1	1	55.125
S02	6.300	X	7.650	1	1	48.195
S03	5.900	X	15.900	1	1	93.810
S04	3.200	X	6.530	1	1	20.896
S05	7.650	X	7.875	1	1	60.244
<b>TOTAL DEDUCTION AREA (B)</b>						<b>278.270</b>
<b>TOTAL PARKING AREA AT EACH FLOOR (C) = (A-B)</b>						<b>1586.690</b>
<b>PARKING AT 4TH, 5TH &amp; 6TH FLOOR (1607.09 / 30)</b>						<b>53</b>
<b>PARKING PROVIDED AT 4TH, 5TH &amp; 6TH FLOOR (54 EACH FLOOR)</b>						<b>53 CAR</b>

SCHEDULE OF OPENINGS				
TYPE	WIDTH	HEIGHT	SILL HT.	LINTEL
D1	750	2100	-	2100
D2	1000	2100	-	2100
D3	1200	2100	-	2100
D4	1050	2100	-	2100
FC01	2150	2100	-	2100
FC02	1500	2100	-	2100
FC03	1700	2100	-	2100
RS	3000	2400	-	2700
W1	1700	2100	900	3000
W2	2058	2100	900	300
W3	2300	2100	900	300
W4	2725	2100	900	300
W5	3300	2100	900	300
DW1	3500	2100	-	-
SD1	2400	2100	-	-

TITLE 4th, 5th & 6th FLOOR PLAN(PARKING)

PROJECT:-  
PROPOSED BUILDING PLAN OF COMMERCIAL AT PLOT NO.:- C-5 , SECTOR DELTA-I, GREATER NOIDA  
M/S KAVERI ELITE INFRA DEVELOPERS PVT. LTD

OWNER 'S SIGNATURE	ARCHITECT 'S SIGNATURE
<p><b>Girish Kumar Goel</b> Digitally signed by Girish Kumar Goel Date: 2026.01.03 22:37:50 +05'30'</p>	<p><b>MAHTAB ALAM SAIFI</b> Digitally signed by MAHTAB ALAM SAIFI Date: 2026.01.03 23:09:56 +05'30'</p>

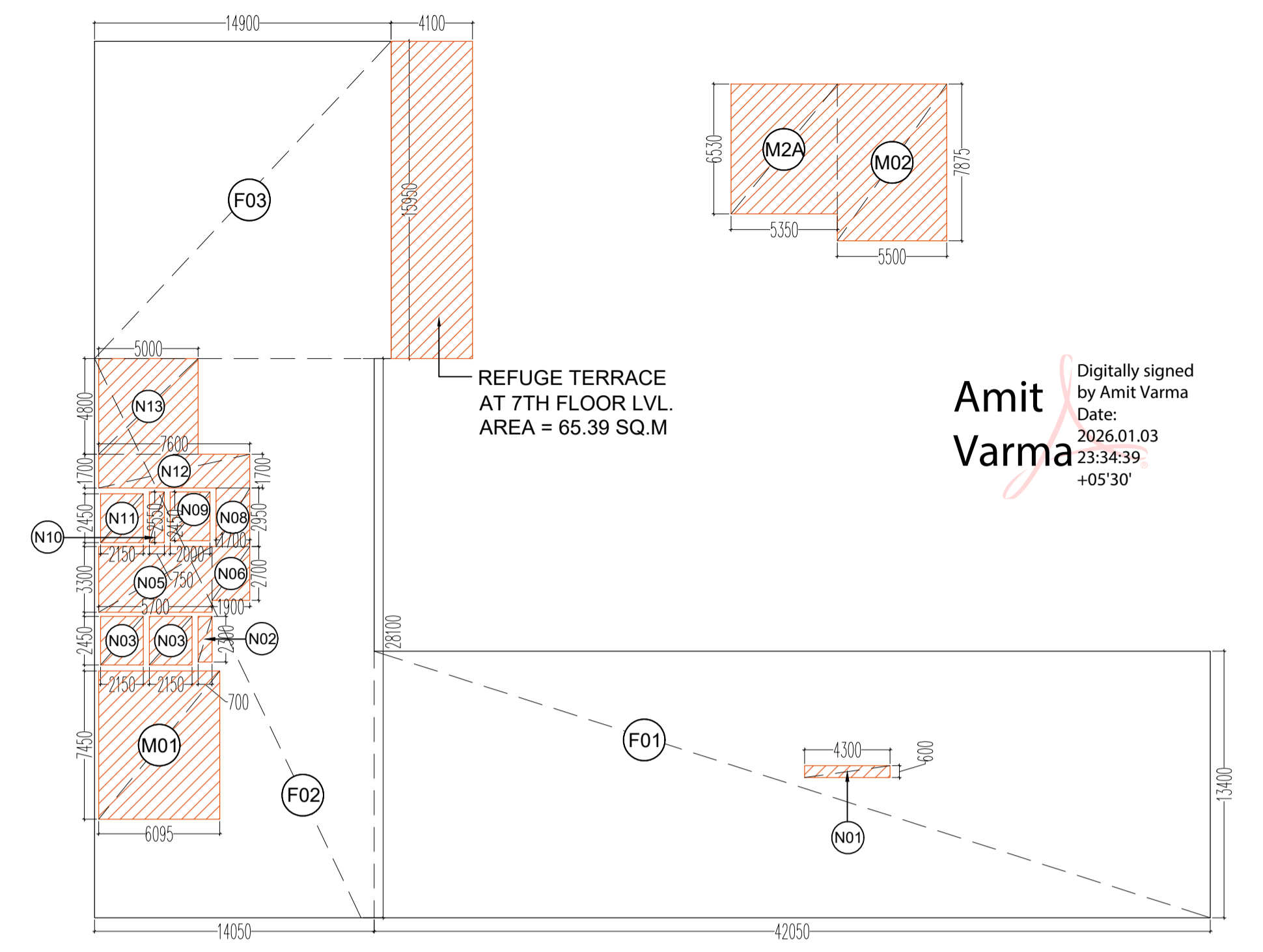
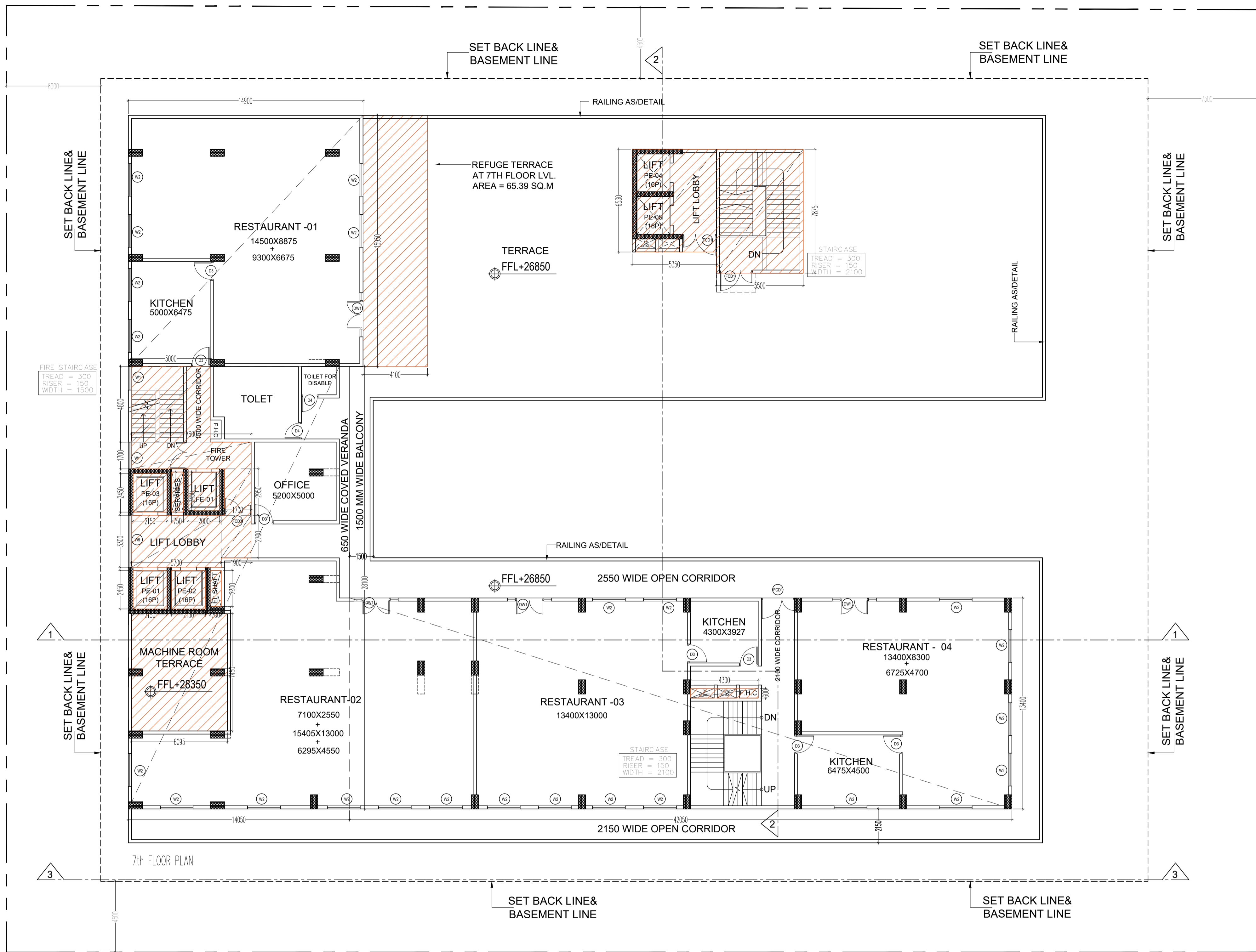

7TH ENVELOPE FLOOR PLAN

7TH FLOOR AREA CALCULATION						
FAR AREA = ADDITION AREA - DEDUCTION AREA						
ADDITION AREA						
S. NO.	DIM(m)	X	DIM(m)	FEC.	NOS.	AREA(SQM.)
F01	42.050	X	13.400	1	1	563.470
F02	14.050	X	28.100	1	1	394.805
F03	14.900	X	15.950	1	1	237.655
<b>TOTAL ADDITION AREA (A)</b>						<b>1195.930</b>
DEDUCTION AREA						
N01	4.300	X	0.600	1	1	2.580
N02	0.700	X	2.300	1	1	1.610
N03	2.150	X	2.450	1	2	10.535
N05	5.700	X	3.300	1	1	18.810
N06	1.900	X	2.700	1	1	5.130
N08	1.700	X	2.950	1	1	5.015
N09	2.000	X	2.450	1	1	4.900
N10	0.750	X	2.550	1	1	1.913
N11	2.150	X	2.450	1	1	5.268
N12	7.600	X	1.700	1	1	12.920
N13	5.000	X	4.800	1	1	24.000
<b>TOTAL DEDUCTION AREA (B)</b>						<b>92.680</b>
<b>FAR AREA AT 7TH FLOOR (C) = (A-B)</b>						<b>1103.250</b>

SCHEDULE OF OPENINGS				
TYPE	WIDTH	HEIGHT	SILL HT.	LINTEL
D1	750	2100	-	2100
D2	1000	2100	-	2100
D3	1200	2100	-	2100
D4	1050	2100	-	2100
FCD1	2150	2100	-	2100
FCD2	1500	2100	-	2100
FCD3	1700	2100	-	2100
RS	3000	2400	-	2700
W1	1700	2100	900	3000
W2	2058	2100	900	300
W3	2300	2100	900	300
W4	2725	2100	900	300
W5	3300	2100	900	300
DW1	3500	2100	-	-
SD1	2400	2100	-	-

SERVICES AREA AT 7TH FLOOR						
N01	4.300	X	0.600	1	1	2.580
N02	0.700	X	2.300	1	1	1.610
N03	2.150	X	2.450	1	2	10.535
N05	5.700	X	3.300	1	1	18.810
N06	1.900	X	2.700	1	1	5.130
N08	1.700	X	2.950	1	1	5.015
N09	2.000	X	2.450	1	1	4.900
N10	0.750	X	2.550	1	1	1.913
N11	2.150	X	2.450	1	1	5.268
N12	7.600	X	1.700	1	1	12.920
N13	5.000	X	4.800	1	1	24.000
M01	5.500	X	7.875	1	1	43.313
M1A	5.350	X	6.530	1	1	34.936
<b>TOTAL SERVICES AREA AT 7TH FLOOR</b>						<b>170.928</b>

REFUGE AREA CALCULATION (7TH FLOOR)	
FAR Area at 7th Floor (Restaurant Floor)	1048.29
FAR Area at 8th Floor (Rooms)	1011.11
<b>Total FAR Area</b>	<b>2059.39</b>
Total No. of Occupants	Occupants Load = 10 Sq.Mt/Person
205.94	205.94
Refuge Area Required	Occupant X 0.3
61.78	61.78
Refuge Area Required for Wheel Chair Person	0.9 Sq.Mt for every 200 Occupants
0.93	0.93
<b>Net Refuge Area Required</b>	<b>62.71</b>
Refuge Area Provided (Service Area 15%)	65.39

**TITLE** 7th FLOOR PLAN

**PROJECT:-**  
 PROPOSED BUILDING PLAN OF COMMERCIAL AT PLOT NO.-: C-5 , SECTOR DELTA-I, GREATER NOIDA  
 M/S KAVERI ELITE INFRA DEVELOPERS PVT. LTD

**OWNER 'S SIGNATURE**      **ARCHITECT 'S SIGNATURE**

Digitally signed by **Girish Kumar Goel**  
 Date: 2026.01.03 22:38:40 +05'30'

Digitally signed by **MAHTAB ALAM SAIFI**  
 Date: 2026.01.03 23:08:25 +05'30'

Digitally signed by **Amit Varma**  
 Date: 2026.01.03 23:34:39 +05'30'

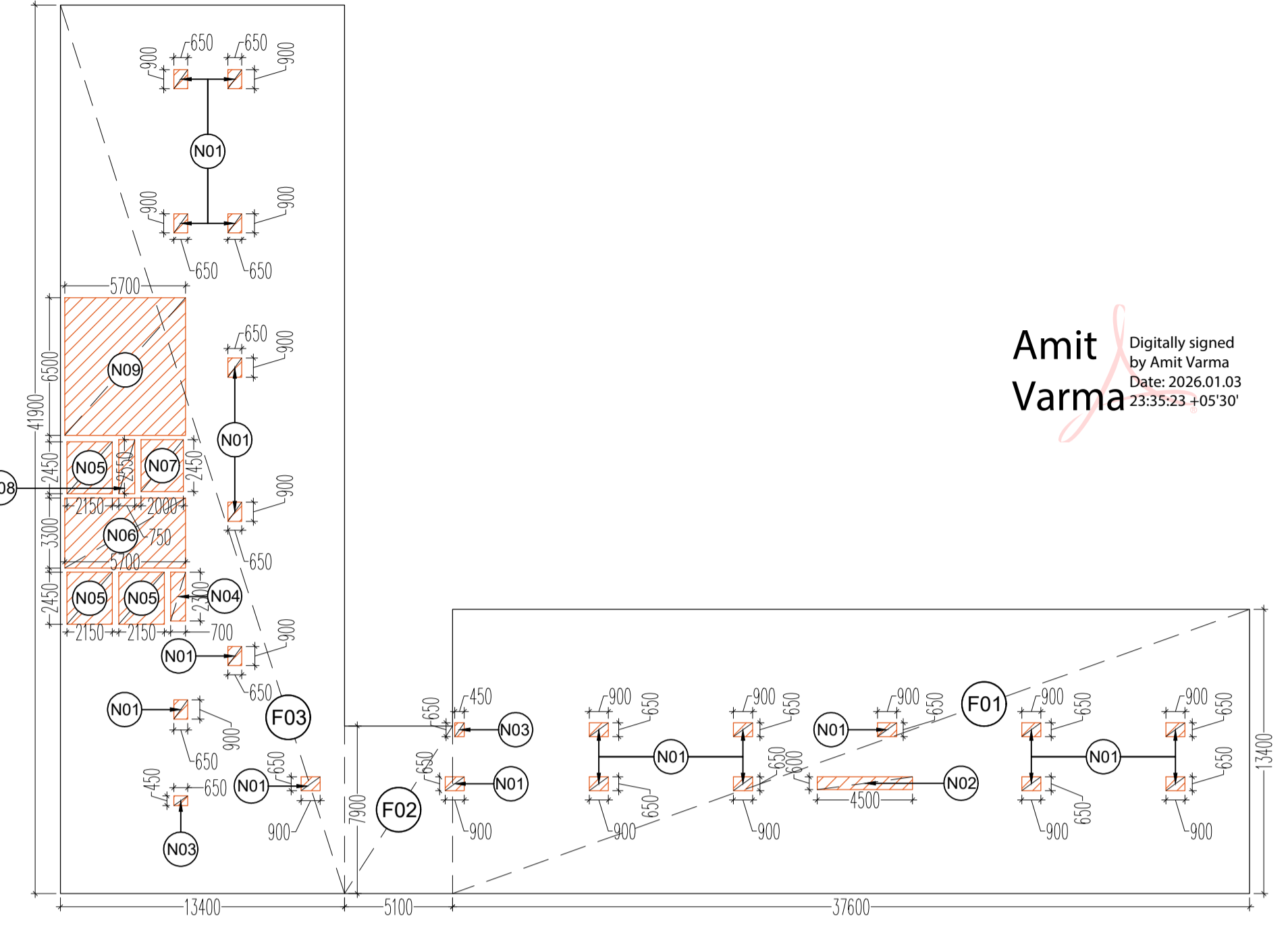
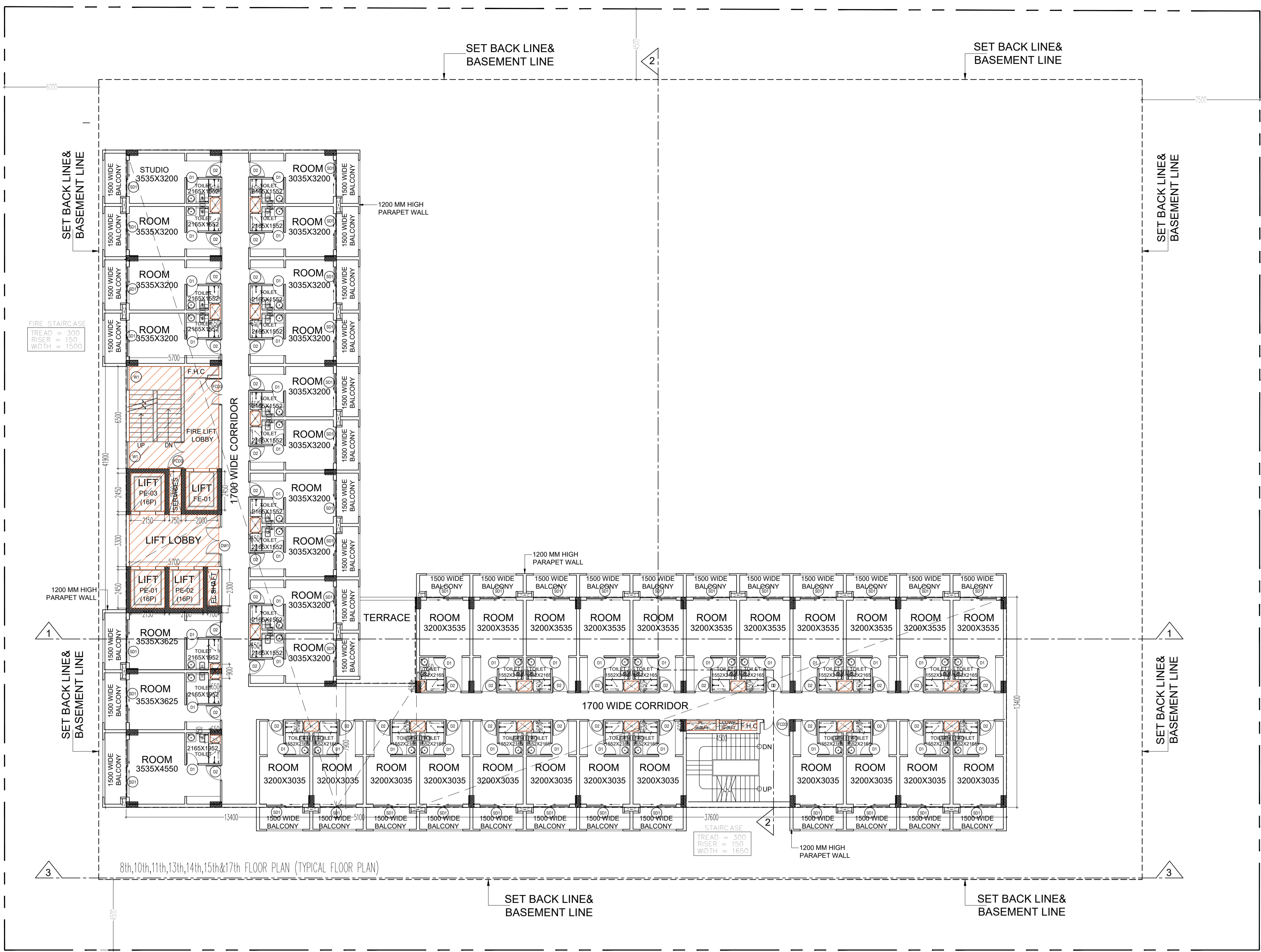

8th,10th,11th,13th,14th,15th&17th FLOOR ENVELOPE PLAN (TYPICAL FLOOR PLAN)

TYPICAL FLOOR (8TH,10TH,11TH,13TH,14TH,15TH & 17TH) AREA CALCULATION						
FAR AREA = ADDITION AREA - DEDUCTION AREA						
ADDITION AREA						
S. NO.	DIM (m)	X	DIM (m)	FEC.	NOS.	AREA (SQM.)
F01	37.600	X	13.400	1	1	503.840
F02	5.100	X	7.900	1	1	40.290
F03	13.400	X	41.900	1	1	561.460
<b>TOTAL ADDITION AREA (A)</b>						<b>1105.590</b>
DEDUCTION AREA						
N01	0.900	X	0.650	1	19	11.115
N02	4.500	X	0.600	1	1	2.700
N03	0.450	X	0.650	1	2	0.585
N04	0.700	X	2.300	1	1	1.610
N05	2.150	X	2.450	1	3	15.803
N06	5.700	X	3.300	1	1	18.810
N07	2.000	X	2.450	1	1	4.900
N08	0.750	X	2.550	1	1	1.913
N09	5.700	X	6.500	1	1	37.050
<b>TOTAL DEDUCTION AREA (B)</b>						<b>94.485</b>
<b>TOTAL FAR AREA AT TYPICAL (8TH,10TH,11TH,13TH,14TH,15TH &amp; 17TH) FLOOR (C) = (A-B)</b>						<b>1011.105</b>
SERVICES AREA AT TYPICAL FLOOR (8TH,10TH,11TH,13TH,14TH,15TH & 17TH)						
N01	0.900	X	0.650	1	19	11.115
N02	4.500	X	0.600	1	1	2.700
N03	0.450	X	0.650	1	2	0.585
N04	0.700	X	2.300	1	1	1.610
N05	2.150	X	2.450	1	3	15.803
N06	5.700	X	3.300	1	1	18.810
N07	2.000	X	2.450	1	1	4.900
N08	0.750	X	2.550	1	1	1.913
N09	5.700	X	6.500	1	1	37.050
<b>TOTAL SERVICES AREA AT TYPICAL FLOOR (8TH,10TH,11TH,13TH,14TH,15TH &amp; 17TH) (S)</b>						<b>94.485</b>

SCHEDULE OF OPENINGS				
TYPE	WIDTH	HEIGHT	SILL HT.	LINTEL
D1	750	2100	-	2100
D2	1000	2100	-	2100
D3	1200	2100	-	2100
D4	1050	2100	-	2100
FCD1	2150	2100	-	2100
FCD2	1500	2100	-	2100
FCD3	1700	2100	-	2100
RS	3000	2400	-	2700
W1	1700	2100	900	3000
W2	2058	2100	900	300
W3	2300	2100	900	300
W4	2725	2100	900	300
W5	3300	2100	900	300
DW1	3500	2100	-	-
SD1	2400	2100	-	-

TITLE 8th,10th,11th,13th,14th,15th&17th FLOOR PLAN (TYPICAL)

PROJECT:-  
PROPOSED BUILDING PLAN OF COMMERCIAL AT PLOT NO.- C-5 , SECTOR DELTA-I, GREATER NOIDA  
M/S KAVERI ELITE INFRA DEVELOPERS PVT. LTD

OWNER 'S SIGNATURE ARCHITECT 'S SIGNATURE

**Girish Kumar Goel**  
Digitally signed by Girish Kumar Goel  
Date: 2026.01.03 22:39:43 +05'30'

**MAHTAB ALAM SAIFI**  
Digitally signed by MAHTAB ALAM SAIFI  
Date: 2026.01.03 23:06:32 +05'30'

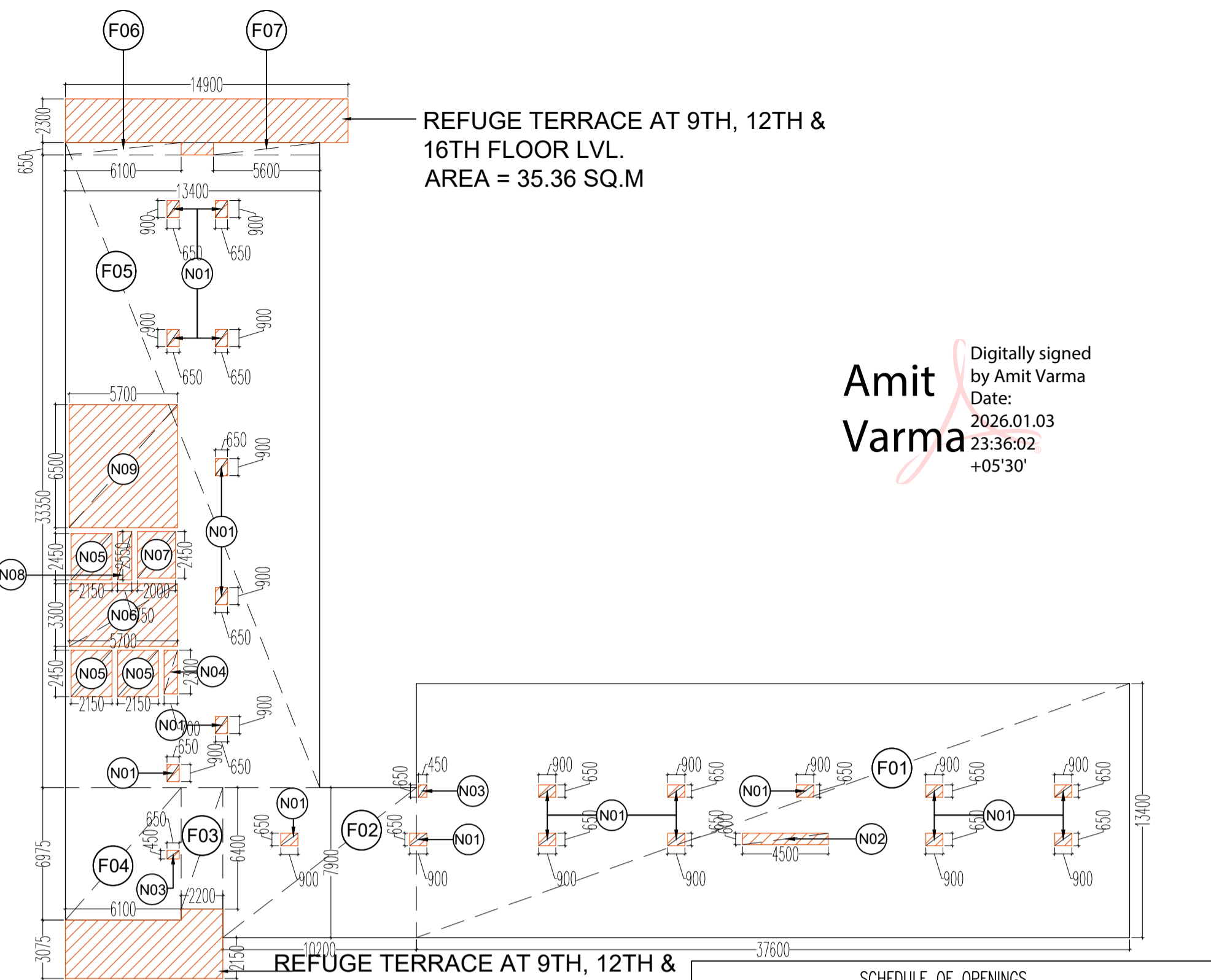
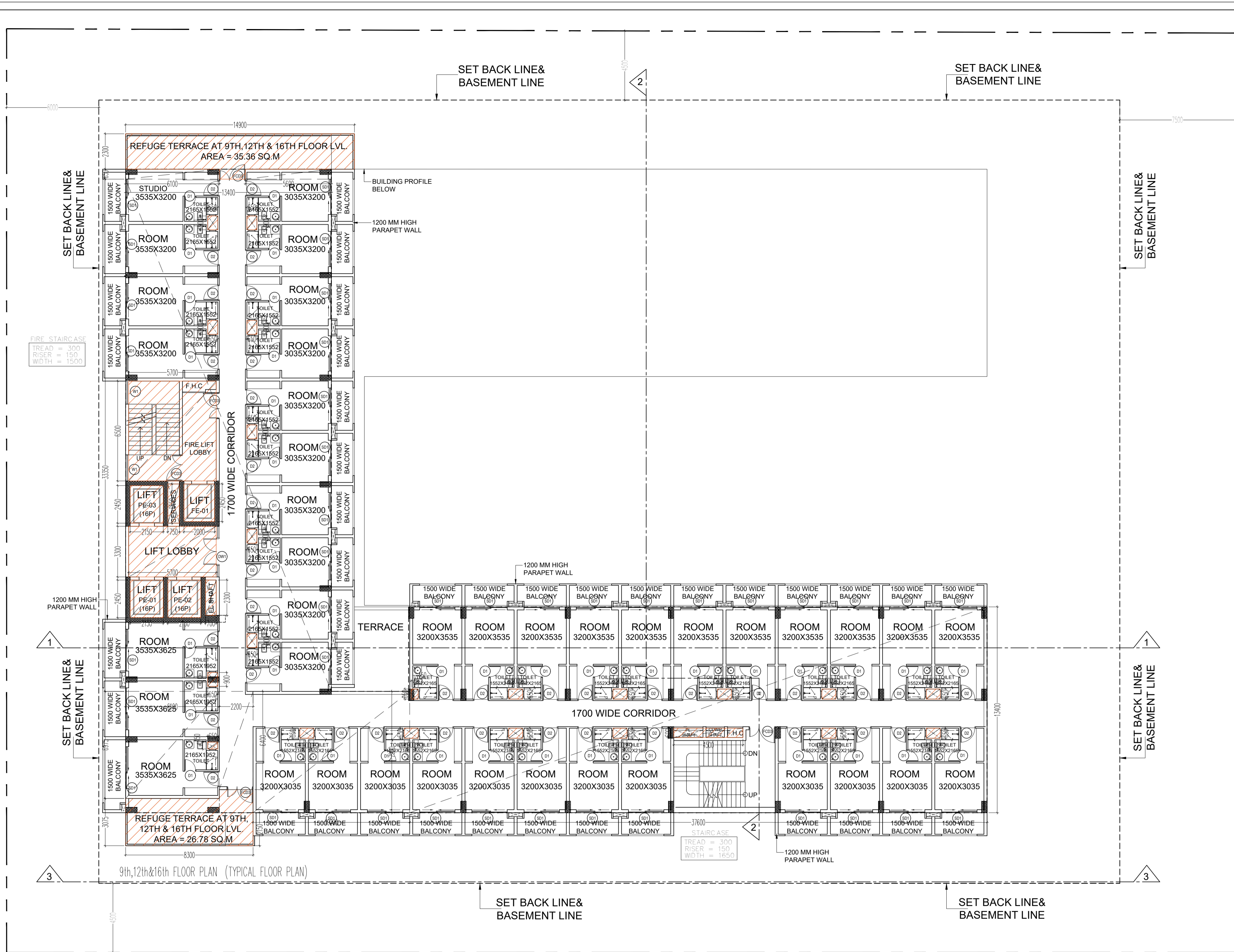

**Amit Varma**  
Digitally signed by Amit Varma  
Date: 2026.01.03 23:36:02 +05'30'

9th, 12th, & 16th FLOOR ENVELOPE PLAN (TYPICAL FLOOR PLAN)

SCHEDULE OF OPENINGS				
TYPE	WIDTH	HEIGHT	SILL HT.	LINTEL
D1	750	2100	-	2100
D2	1000	2100	-	2100
D3	1200	2100	-	2100
D4	1050	2100	-	2100
FCD1	2150	2100	-	2100
FCD2	1500	2100	-	2100
FCD3	1700	2100	-	2100
RS	3000	2400	-	2700
W1	1700	2100	900	3000
W2	2058	2100	900	300
W3	2300	2100	900	300
W4	2725	2100	900	300
W5	3300	2100	900	300
DW1	3500	2100	-	-
SD1	2400	2100	-	-

TYPICAL FLOOR (9TH, 12TH & 16TH) AREA CALCULATION				
FAR AREA = ADDITION AREA - DEDUCTION AREA				
ADDITION AREA				
S. NO.	DIR.(m)	X	DIR.(m)	REC. NOS.
F01	27.600	X	13.400	1
F02	10.200	X	7.900	1
F03	2.200	X	6.400	1
F04	6.100	X	6.975	1
F05	13.400	X	33.350	1
F06	6.100	X	0.650	1
F07	5.600	X	0.650	1
TOTAL ADDITION AREA (A)				1095.548
DEDUCTION AREA				
N01	0.900	X	0.650	1
N02	4.500	X	0.650	1
N03	0.450	X	0.650	1
N04	0.700	X	2.300	1
N05	2.150	X	2.450	1
N06	5.200	X	3.200	1
N07	2.000	X	2.450	1
N08	0.750	X	2.550	1
N09	5.200	X	6.500	1
TOTAL DEDUCTION AREA (B)				94.485
TOTAL FAR AREA AT TYPICAL FLOOR (9TH, 12TH & 16TH) (C) = (A-B)				1001.063
SERVICES AREA AT TYPICAL FLOOR (9TH, 12TH & 16TH)				
S01	0.900	X	0.650	1
S02	4.500	X	0.650	1
S03	0.450	X	0.650	1
S04	0.700	X	2.300	1
S05	2.150	X	2.450	1
S06	5.200	X	3.200	1
S07	2.000	X	2.450	1
S08	0.750	X	2.550	1
S09	5.200	X	6.500	1
TOTAL SERVICES AREA AT TYPICAL FLOOR (9TH, 12TH & 16TH) (S)				94.485

REFUGE AREA CALCULATION (9TH FLOOR)		
FAR Area at 9th Floor (Rooms)		1001.06
FAR Area at 10th floor (Rooms)		1011.11
Total FAR Area		2012.16
Total No. of Occupants	Occupants Load = 10 Sq.Mt/Person	201.22
Refuge Area Required	Occupant X 0.3	60.36
Refuge Area Required for Wheel Chair Person	0.9 Sq.Mt for every 200 Occupants	0.91
Net Refuge Area Required		61.27
Refuge Area Provided (Service Area 15%)		62.15

REFUGE AREA CALCULATION (12TH FLOOR)		
FAR Area at 12th floor (Rooms)		1001.06
FAR Area at 13th floor (Rooms)		1011.11
Total FAR Area		2012.16
Total No. of Occupants	Occupants Load = 10 Sq.Mt/Person	201.22
Refuge Area Required	Occupant X 0.3	60.36
Refuge Area Required for Wheel Chair Person	0.9 Sq.Mt for every 200 Occupants	0.91
Net Refuge Area Required		61.27
Refuge Area Provided (Service Area 15%)		62.15

REFUGE AREA CALCULATION (16TH FLOOR)		
FAR Area at 16th Floor (Rooms)		1001.06
FAR Area at 17th Floor (Rooms)		1011.11
Total FAR Area		2012.16
Total No. of Occupants	Occupants Load = 10 Sq.Mt/Person	201.22
Refuge Area Required	Occupant X 0.3	60.36
Refuge Area Required for Wheel Chair Person	0.9 Sq.Mt for every 200 Occupants	0.91
Net Refuge Area Required		61.27
Refuge Area Provided (Service Area 15%)		62.15

**TITLE** 9th, 12th, & 16th FLOOR PLAN (TYPICAL)

**PROJECT:-**  
PROPOSED BUILDING PLAN OF COMMERCIAL AT PLOT NO.:- C-5 , SECTOR DELTA-I, GREATER NOIDA  
M/S KAVERI ELITE INFRA DEVELOPERS PVT. LTD

<b>OWNER 'S SIGNATURE</b>	<b>ARCHITECT 'S SIGNATURE</b>
<p><b>Girish Kumar Goel</b> Digitally signed by Girish Kumar Goel Date: 2026.01.03 22:40:35 +05'30'</p>	<p><b>MAHTAB ALAM SAIFI</b> Digitally signed by MAHTAB ALAM SAIFI Date: 2026.01.03 23:05:01 +05'30'</p>

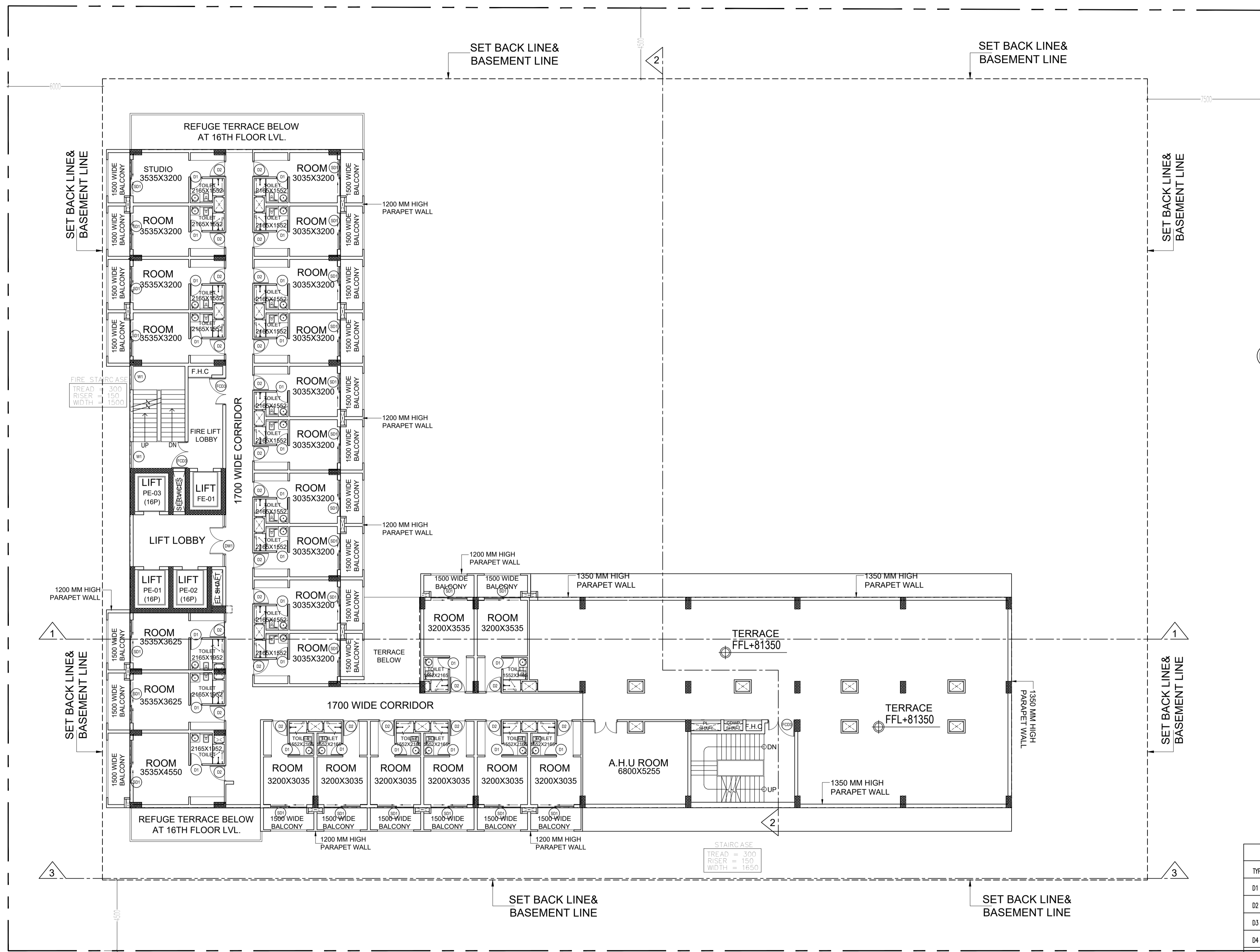

18TH FLOOR PLAN

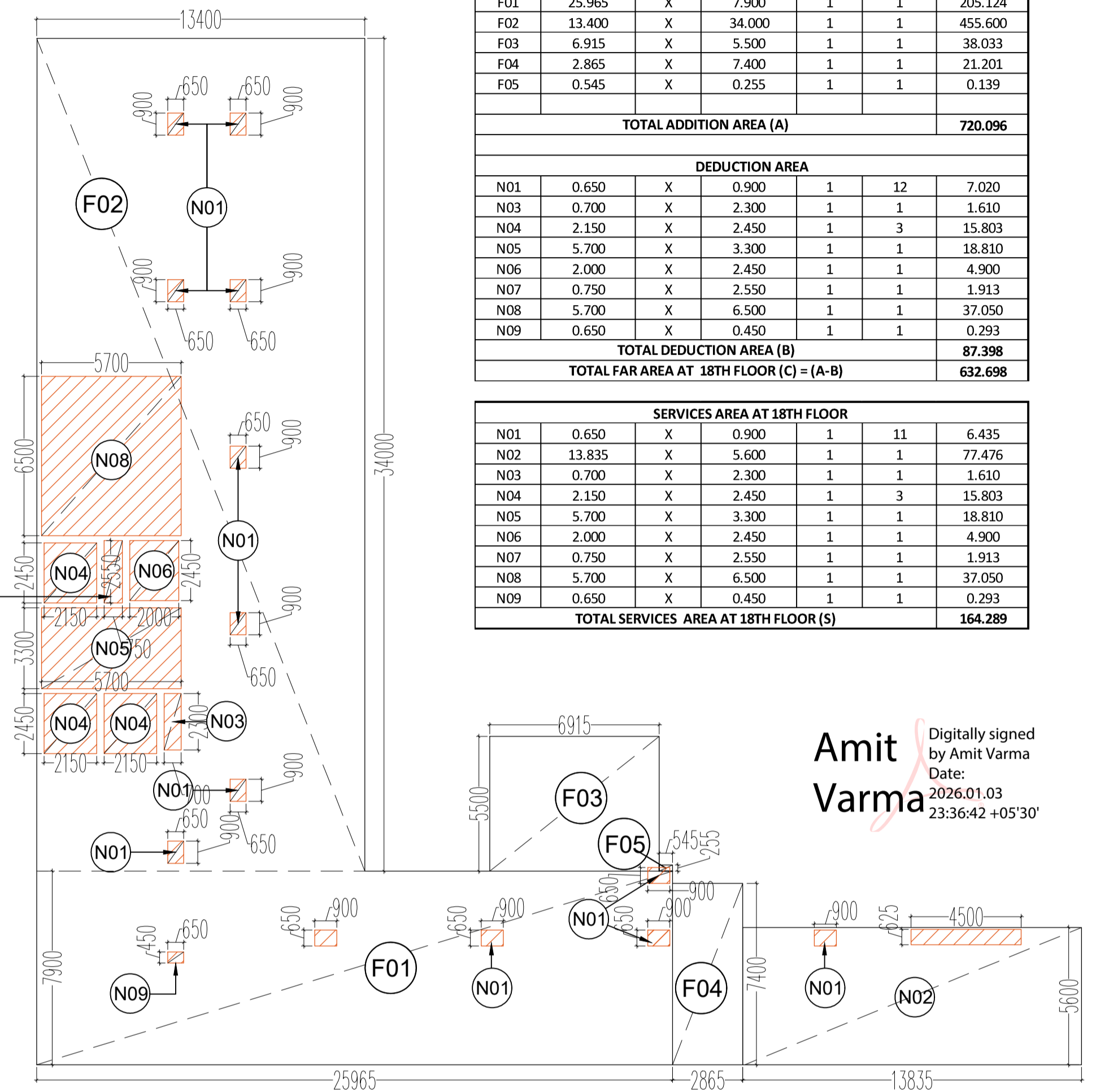

18th FLOOR ENVELOPE PLAN

18TH FLOOR AREA CALCULATION						
FAR AREA = ADDITION AREA - DEDUCTION AREA						
ADDITION AREA						
S. NO.	DIM(m)	X	DIM(m)	FEC.	NOS.	AREA(SQM.)
F01	25.965	X	7.900	1	1	205.124
F02	13.400	X	34.000	1	1	455.600
F03	6.915	X	5.500	1	1	38.033
F04	2.865	X	7.400	1	1	21.201
F05	0.545	X	0.255	1	1	0.139
<b>TOTAL ADDITION AREA (A)</b>						<b>720.096</b>
DEDUCTION AREA						
N01	0.650	X	0.900	1	12	7.020
N03	0.700	X	2.300	1	1	1.610
N04	2.150	X	2.450	1	3	15.803
N05	5.700	X	3.300	1	1	18.810
N06	2.000	X	2.450	1	1	4.900
N07	0.750	X	2.550	1	1	1.913
N08	5.700	X	6.500	1	1	37.050
N09	0.650	X	0.450	1	1	0.293
<b>TOTAL DEDUCTION AREA (B)</b>						<b>87.398</b>
<b>TOTAL FAR AREA AT 18TH FLOOR (C) = (A-B)</b>						<b>632.698</b>

SERVICES AREA AT 18TH FLOOR						
S. NO.	DIM(m)	X	DIM(m)	FEC.	NOS.	AREA(SQM.)
N01	0.650	X	0.900	1	11	6.435
N02	13.835	X	5.600	1	1	77.476
N03	0.700	X	2.300	1	1	1.610
N04	2.150	X	2.450	1	3	15.803
N05	5.700	X	3.300	1	1	18.810
N06	2.000	X	2.450	1	1	4.900
N07	0.750	X	2.550	1	1	1.913
N08	5.700	X	6.500	1	1	37.050
N09	0.650	X	0.450	1	1	0.293
<b>TOTAL SERVICES AREA AT 18TH FLOOR (S)</b>						<b>164.289</b>

Amit Varma  
Digitally signed by Amit Varma  
Date: 2026.01.03 23:36:42 +05'30'

SCHEDULE OF OPENINGS				
TYPE	WIDTH	HEIGHT	SILL HT.	LINTEL
D1	750	2100	-	2100
D2	1000	2100	-	2100
D3	1200	2100	-	2100
D4	1050	2100	-	2100
FD1	2150	2100	-	2100
FD2	1500	2100	-	2100
FD3	1700	2100	-	2100
RS	3000	2400	-	2700
W1	1700	2100	900	3000
W2	2058	2100	900	300
W3	2300	2100	900	300
W4	2725	2100	900	300
W5	3300	2100	900	300
DW1	3500	2100	-	-
SD1	2400	2100	-	-

TITLE 18TH FLOOR PLAN

PROJECT:-  
PROPOSED BUILDING PLAN OF COMMERCIAL AT PLOT NO.:- C-5 , SECTOR DELTA-I, GREATER NOIDA  
M/S KAVERI ELITE INFRA DEVELOPERS PVT. LTD

OWNER'S SIGNATURE	ARCHITECT'S SIGNATURE
<p><b>Girish Kumar Goel</b> Digitally signed by Girish Kumar Goel Date: 2026.01.03 22:41:28 +05'30'</p>	<p><b>MAHTAB ALAM SAIFI</b> Digitally signed by MAHTAB ALAM SAIFI Date: 2026.01.03 23:03:27 +05'30'</p>

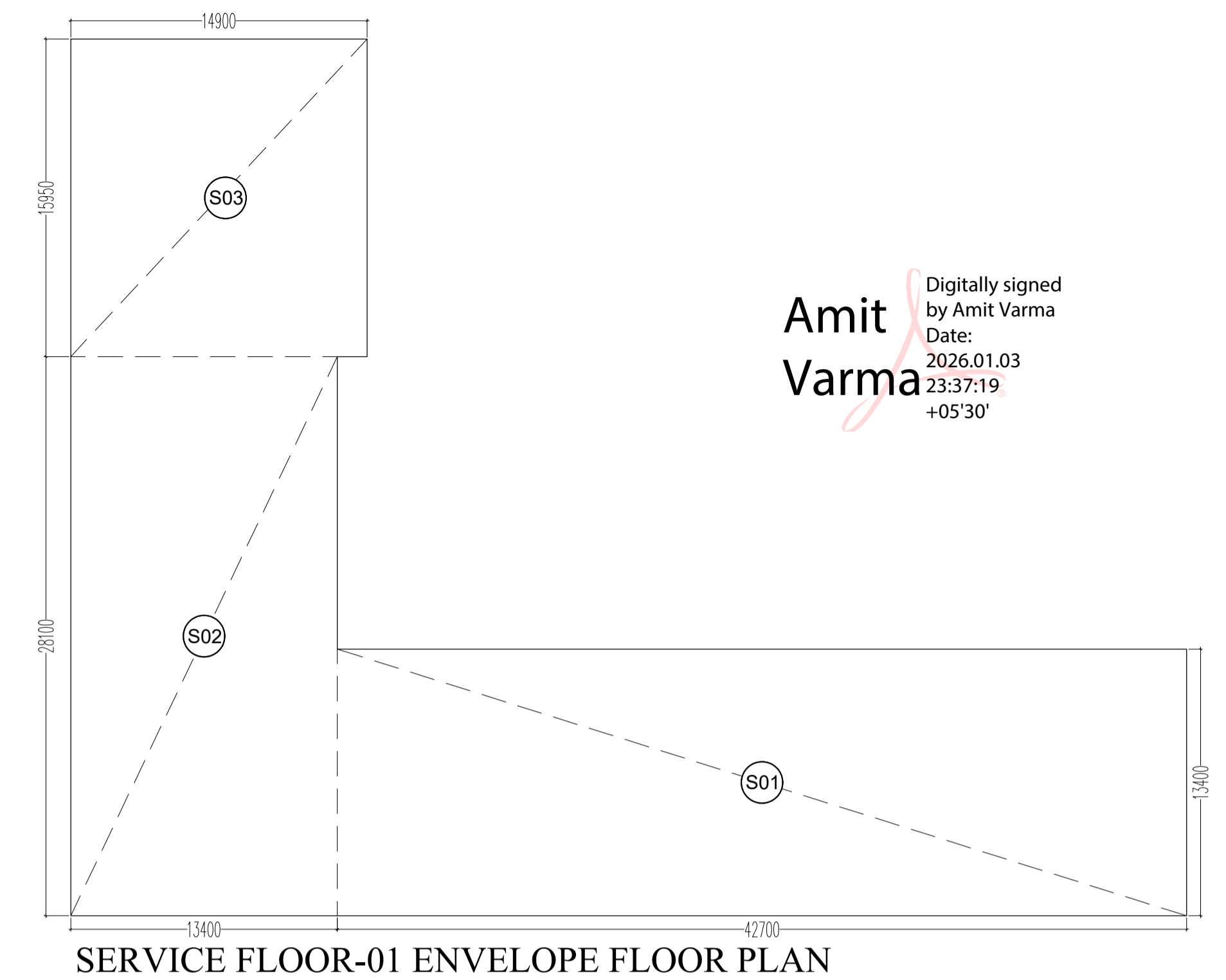
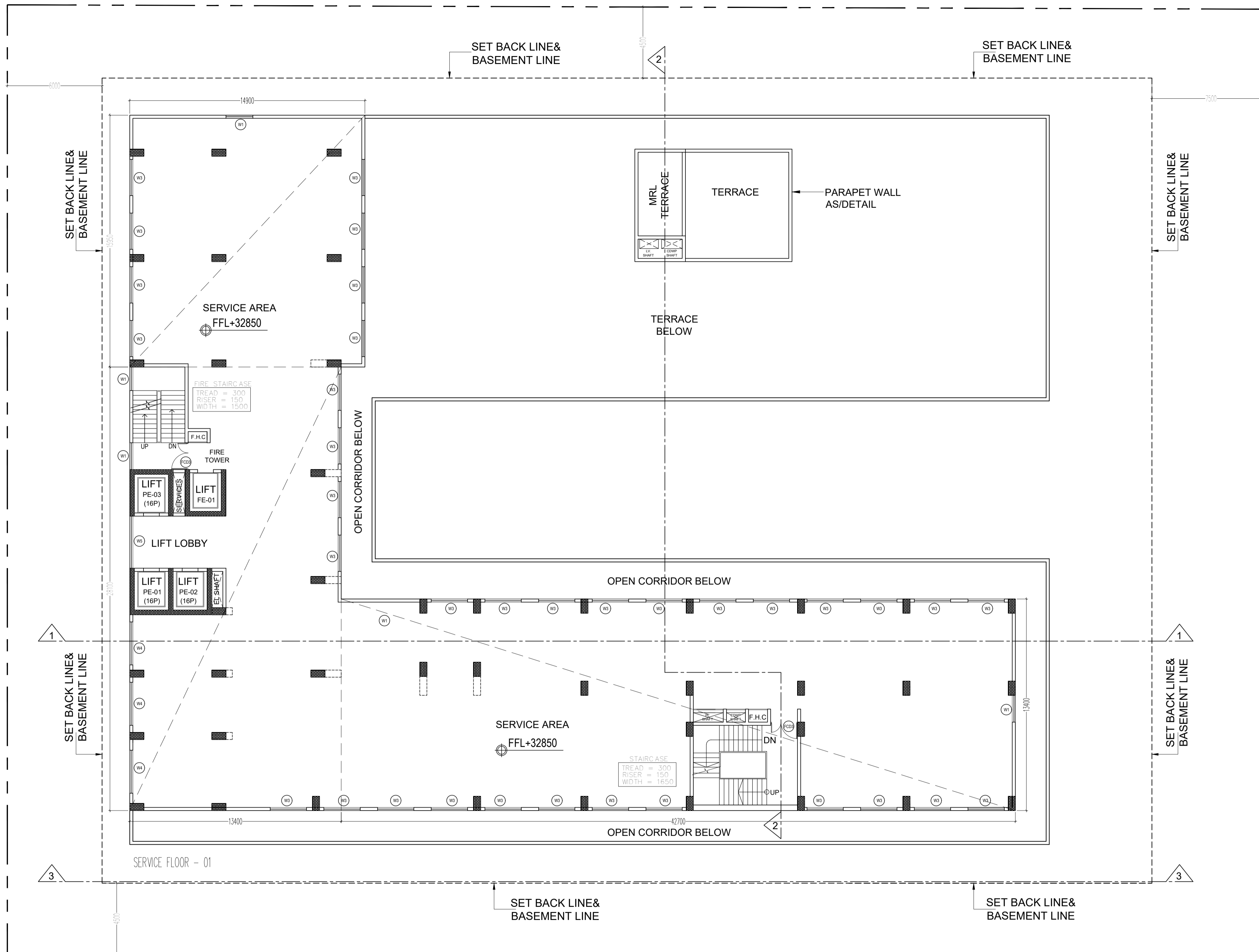

Digitally signed  
by Amit Varma  
Date:  
2026.01.03  
23:37:19  
+05'30'

SERVICE FLOOR-01 ENVELOPE FLOOR PLAN

SERVICE FLOOR-1 AREA CALCULATION						
NON FAR AREA = ADDITION AREA						
ADDITION AREA						
S. NO.	DIM(m)	X	DIM(m)	FEC.	NOS.	AREA(SQ.M)
S01	42.700	X	13.400	1	1	572.180
S02	13.400	X	28.100	1	1	376.540
S03	14.900	X	15.950	1	1	237.655
<b>TOTAL ADDITION AREA (A)</b>						<b>1186.375</b>
<b>TOTAL NON FAR AREA AT SERVICE FLOOR (A)</b>						<b>1186.375</b>

SCHEDULE OF OPENINGS				
TYPE	WIDTH	HEIGHT	SILL HT.	LINTEL
D1	750	2100	-	2100
D2	1000	2100	-	2100
D3	1200	2100	-	2100
D4	1050	2100	-	2100
FD01	2150	2100	-	2100
FD02	1500	2100	-	2100
FD03	1700	2100	-	2100
RS	3000	2400	-	2700
W1	1700	2100	900	3000
W2	2058	2100	900	300
W3	2300	2100	900	300
W4	2725	2100	900	300
W5	3300	2100	900	300
DW1	3500	2100	-	-
SD1	2400	2100	-	-

TITLE		SERVICE FLOOR -01	
PROJECT:-			
PROPOSED BUILDING PLAN OF COMMERCIAL AT PLOT NO.- C-5 , SECTOR DELTA-I, GREATER NOIDA			
M/S KAVERI ELITE INFRA DEVELOPERS PVT. LTD			
OWNER 'S SIGNATURE		ARCHITECT 'S SIGNATURE	
<p>Digitally signed by <b>Girish Kumar Goel</b> Date: 2026.01.03 22:42:19 +05'30'</p>		<p>Digitally signed by <b>MAHTAB ALAM SAIFI</b> Date: 2026.01.03 23:02:00 +05'30'</p>	

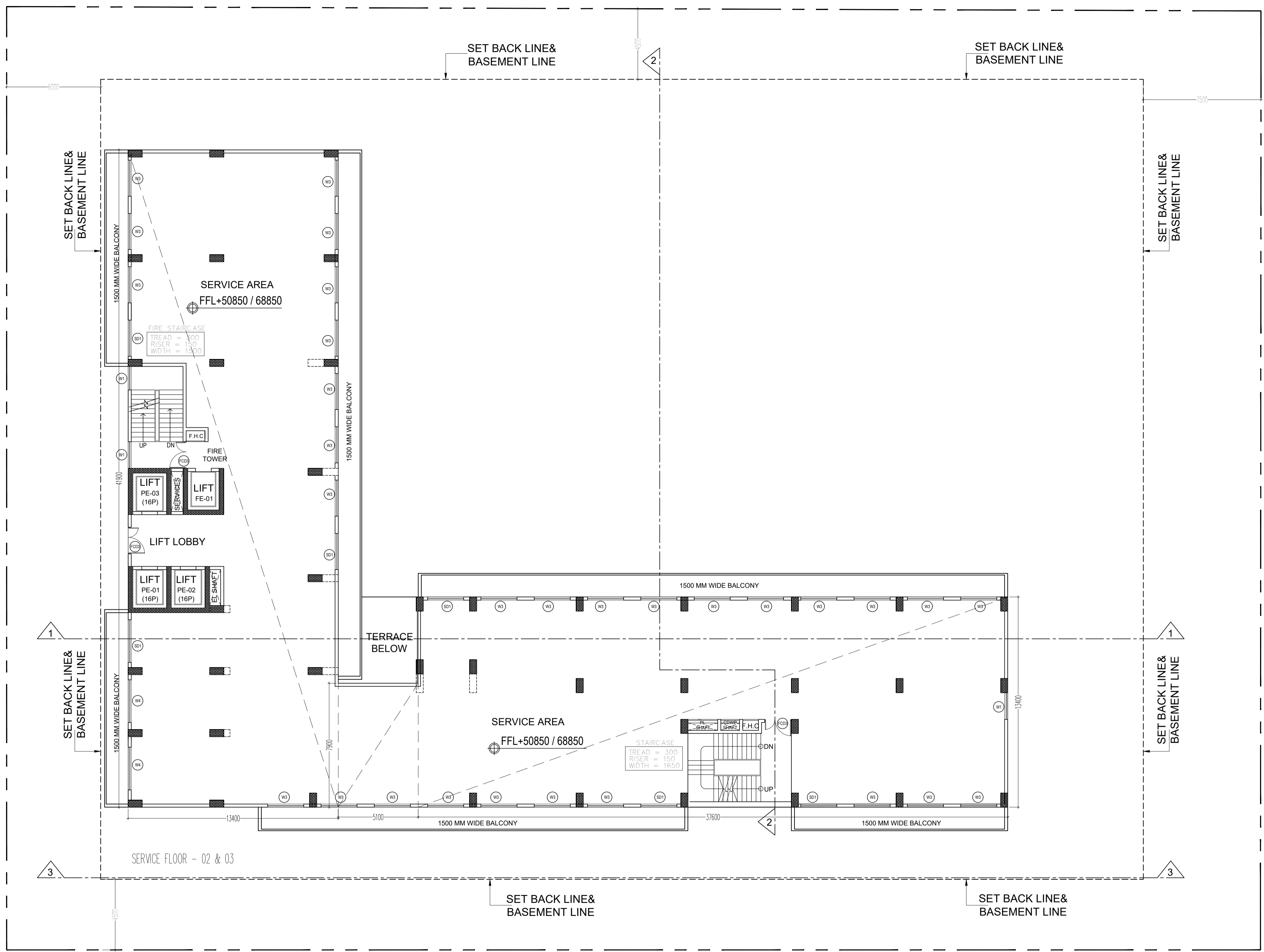

SERVICE FLOOR-2 & 3 AREA CALCULATION						
NON FAR AREA = ADDITION AREA						
ADDITION AREA						
S. NO.	DIM(m)	X	DIM(m)	FEC.	NOS.	AREA(SQ.M.)
S01	37.600	X	13.400	1	1	503.840
S02	5.100	X	7.900	1	1	40.290
S03	13.400	X	41.900	1	1	561.460
TOTAL ADDITION AREA (A)						1105.590
TOTAL NON FAR AREA AT SERVICE FLOOR 2 & 3 (A)						1105.590

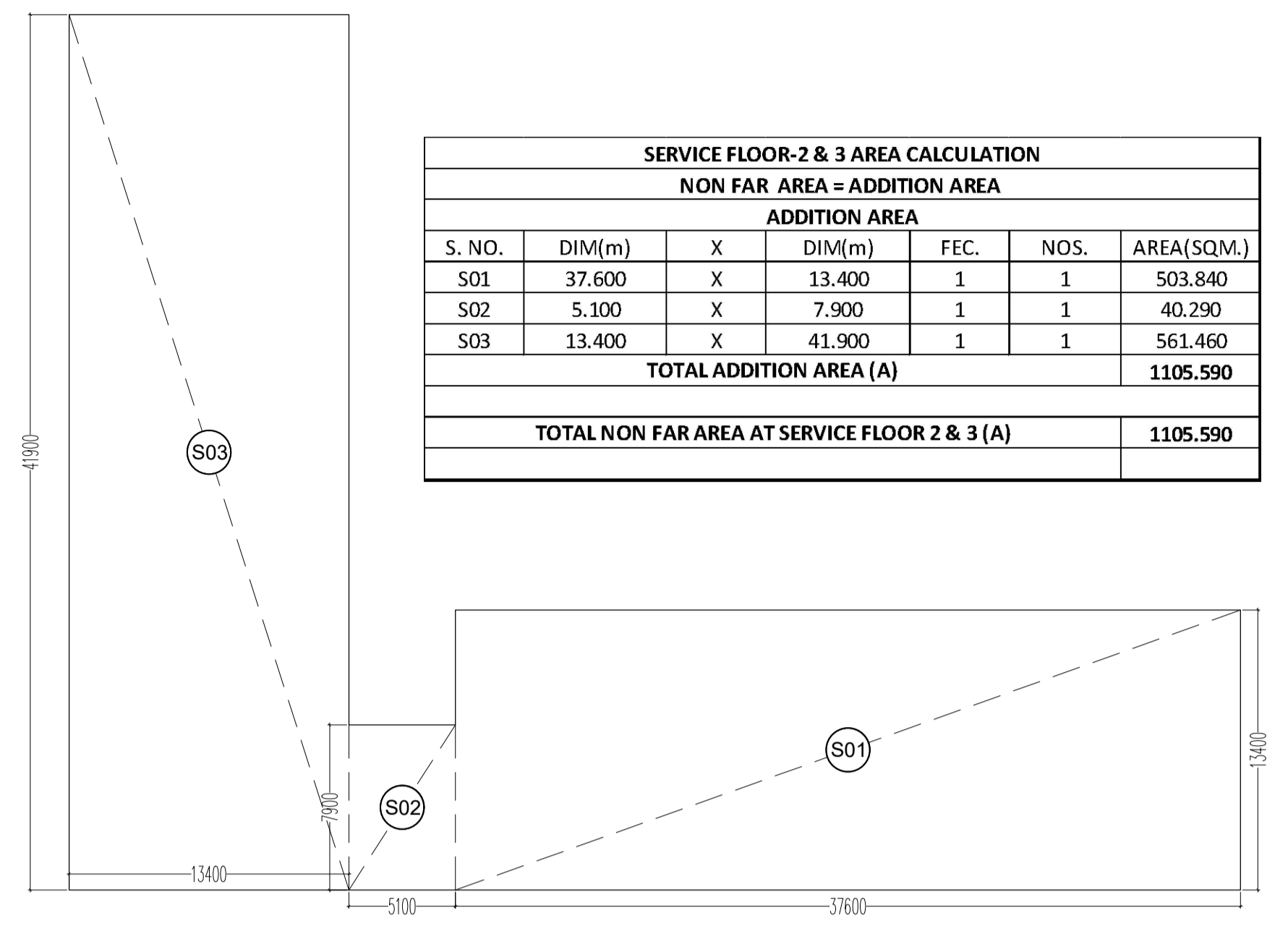

SERVICE FLOOR-02 & 03 ENVELOPE FLOOR PLAN

SCHEDULE OF OPENINGS				
TYPE	WIDTH	HEIGHT	SILL. HT.	LINTEL
D1	750	2100	-	2100
D2	1000	2100	-	2100
D3	1200	2100	-	2100
D4	1050	2100	-	2100
FCD1	2150	2100	-	2100
FCD2	1500	2100	-	2100
FCD3	1700	2100	-	2100
RS	3000	2400	-	2700
W1	1700	2100	900	3000
W2	2058	2100	900	300
W3	2300	2100	900	300
W4	2725	2100	900	300
W5	3300	2100	900	300
DW1	3500	2100	-	-
SD1	2400	2100	-	-

Digitally signed  
by Amit Varma  
Date:  
2026.01.03  
23:37:58  
+05'30'

TITLE SERVICE FLOOR -02 & 03	
PROJECT:- PROPOSED BUILDING PLAN OF COMMERCIAL AT PLOT NO.:- C-5 , SECTOR DELTA-I, GREATER NOIDA M/S KAVERI ELITE INFRA DEVELOPERS PVT. LTD	
OWNER 'S SIGNATURE	ARCHITECT 'S SIGNATURE
<p>Digitally signed by <b>Girish Kumar Goel</b> Date: 2026.01.03 22:43:11 +05'30'</p>	<p>Digitally signed by <b>MAHTAB ALAM SAIFI</b> Date: 2026.01.03 23:00:35 +05'30'</p>



SECTION 1-1

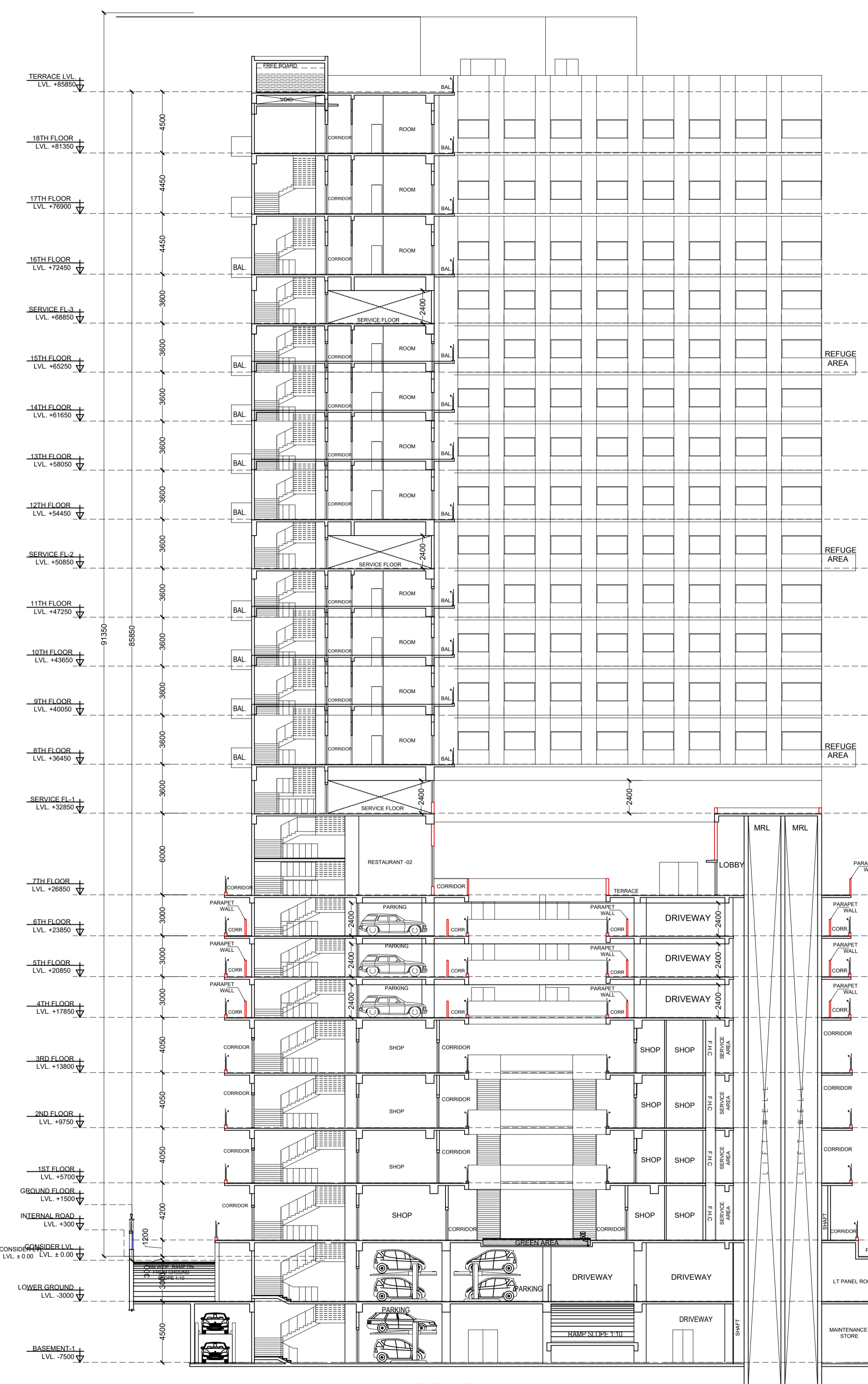

SECTION AT 2-2

**Amit Varma** Digitally signed by Amit Varma Date: 2026.01.03 23:38:44 +05'30'

TITLE SECTION 1-1 & 2-2

PROJECT:- PROPOSED BUILDING PLAN OF COMMERCIAL AT PLOT NO.- C-5, SECTOR DELTA-I, GREATER NOIDA M/S KAVERI ELITE INFRA DEVELOPERS PVT. LTD

OWNER'S SIGNATURE	ARCHITECT'S SIGNATURE
<p><b>Girish Kumar Goel</b> Digitally signed by Girish Kumar Goel Date: 2026.01.03 22:44:11 +05'30'</p>	<p><b>MAH TAB ALAM SAIFI</b> Digitally signed by MAHTAB ALAM SAIFI Date: 2026.01.03 22:59:08 +05'30'</p>

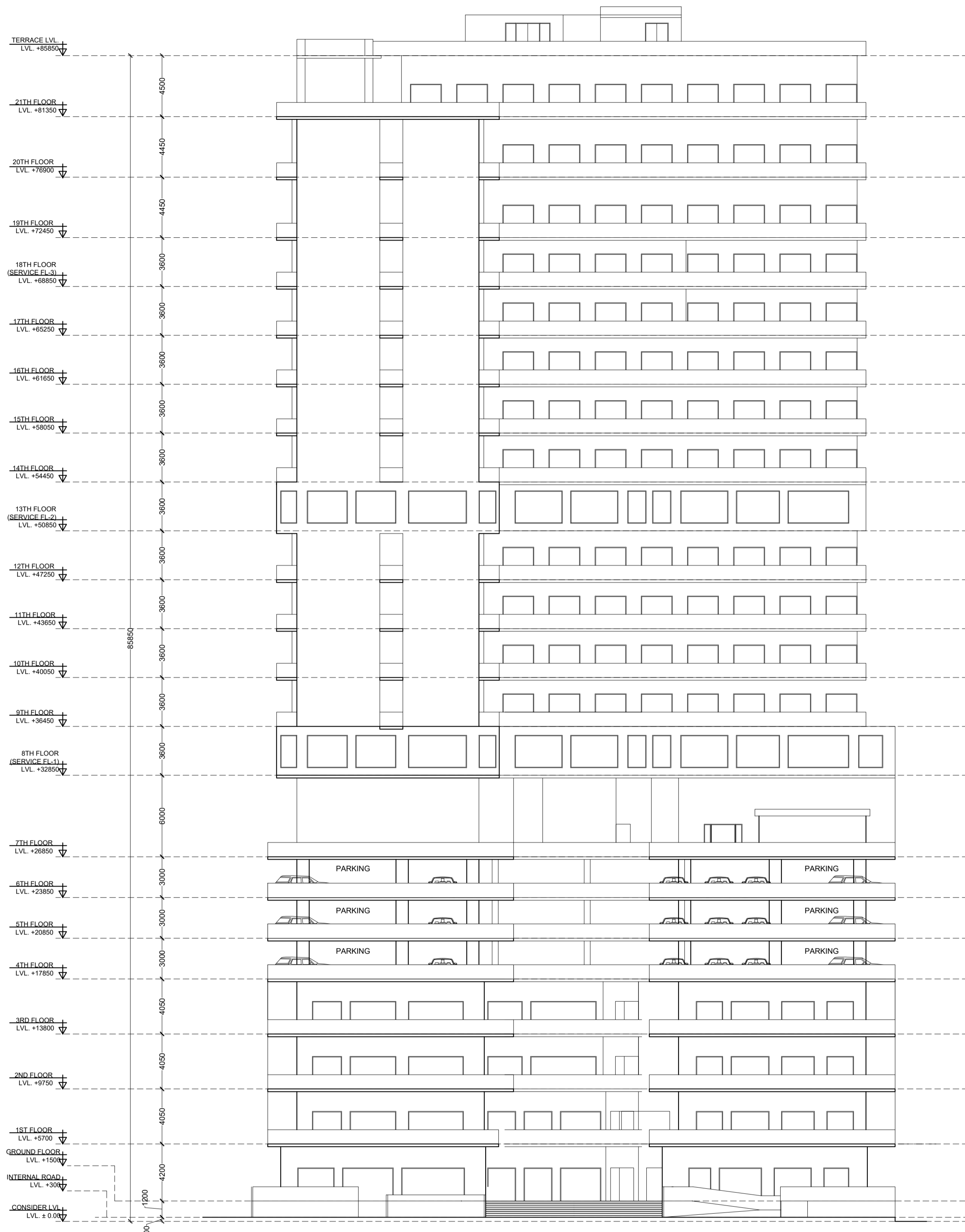

FRONT ELEVATION



RIGHT SIDE ELEVATION

Amit Varma  
Digitally signed by Amit Varma  
Date: 2026.01.03 23:39:32 +05'30'

TITLE FRONT AND RIGHT SIDE ELEVATION	
PROJECT:- PROPOSED BUILDING PLAN OF COMMERCIAL AT PLOT NO.-: C-5 , SECTOR DELTA-I, GREATER NOIDA M/S KAVERI ELITE INFRA DEVELOPERS PVT. LTD	
OWNER 'S SIGNATURE	ARCHITECT 'S SIGNATURE
<p>Girish Kumar Goel</p> <p>Digitally signed by Girish Kumar Goel Date: 2026.01.03 22:45:06 +05'30'</p>	<p>MAHTAB ALAM SAIFI</p> <p>Digitally signed by MAHTAB ALAM SAIFI Date: 2026.01.03 22:50:10 +05'30'</p>

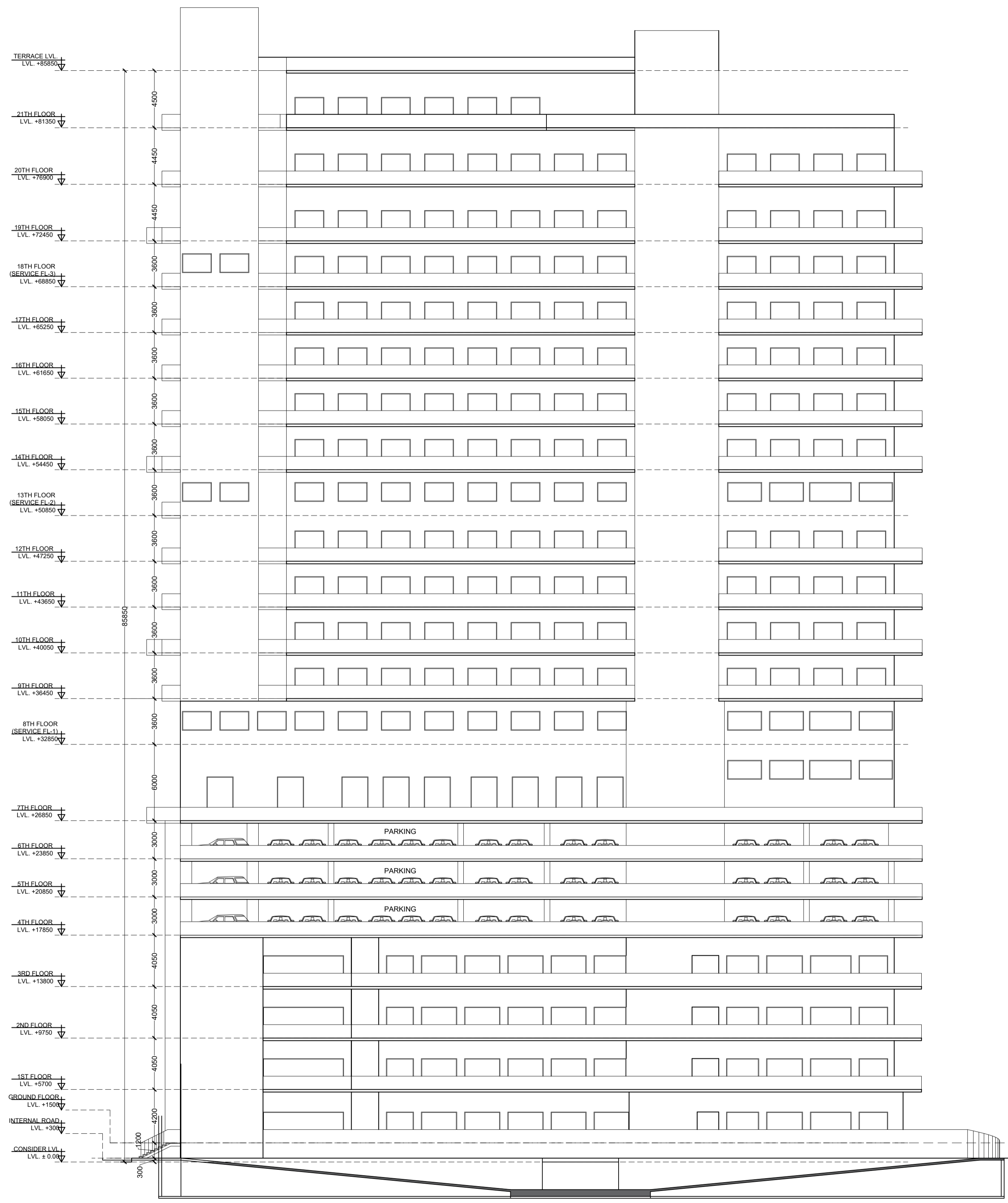

SECTION AT 3-3

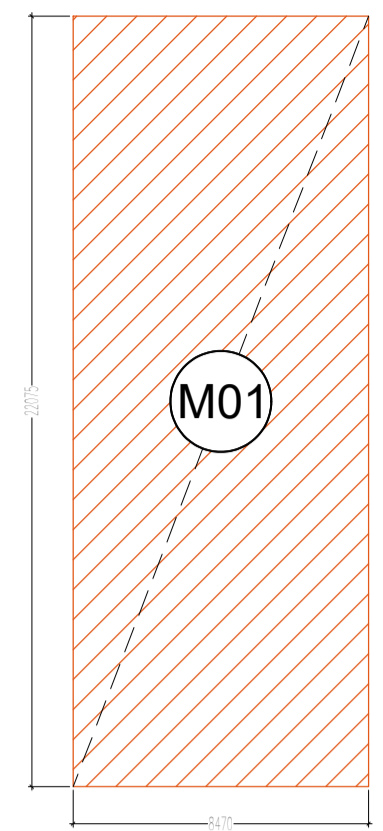

AREA DIAGRAM MUMTY & MACHINE ROOM

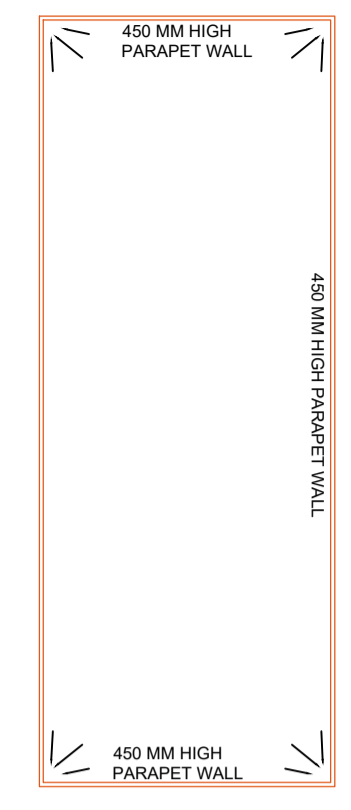

TERRACE MUMTY & MACHINE ROOM

SCHEDULE OF OPENINGS				
TYPE	WIDTH	HEIGHT	SILL HT.	LUNEL
D1	750	2100	-	2100
D2	1000	2100	-	2100
D3	1200	2100	-	2100
D4	1050	2100	-	2100
FD01	2150	2100	-	2100
FD02	1500	2100	-	2100
FD03	1700	2100	-	2100
RS	3000	2400	-	2700
W1	1700	2100	900	3000
W2	2058	2100	900	300
W3	2300	2100	900	300
W4	2725	2100	900	300
W5	3300	2100	900	300
DW1	3500	2100	-	-
SD1	2400	2100	-	-

**Amit Varma**  
Digitally signed by Amit Varma  
Date: 2026.01.03 23:40:09 +05'30'

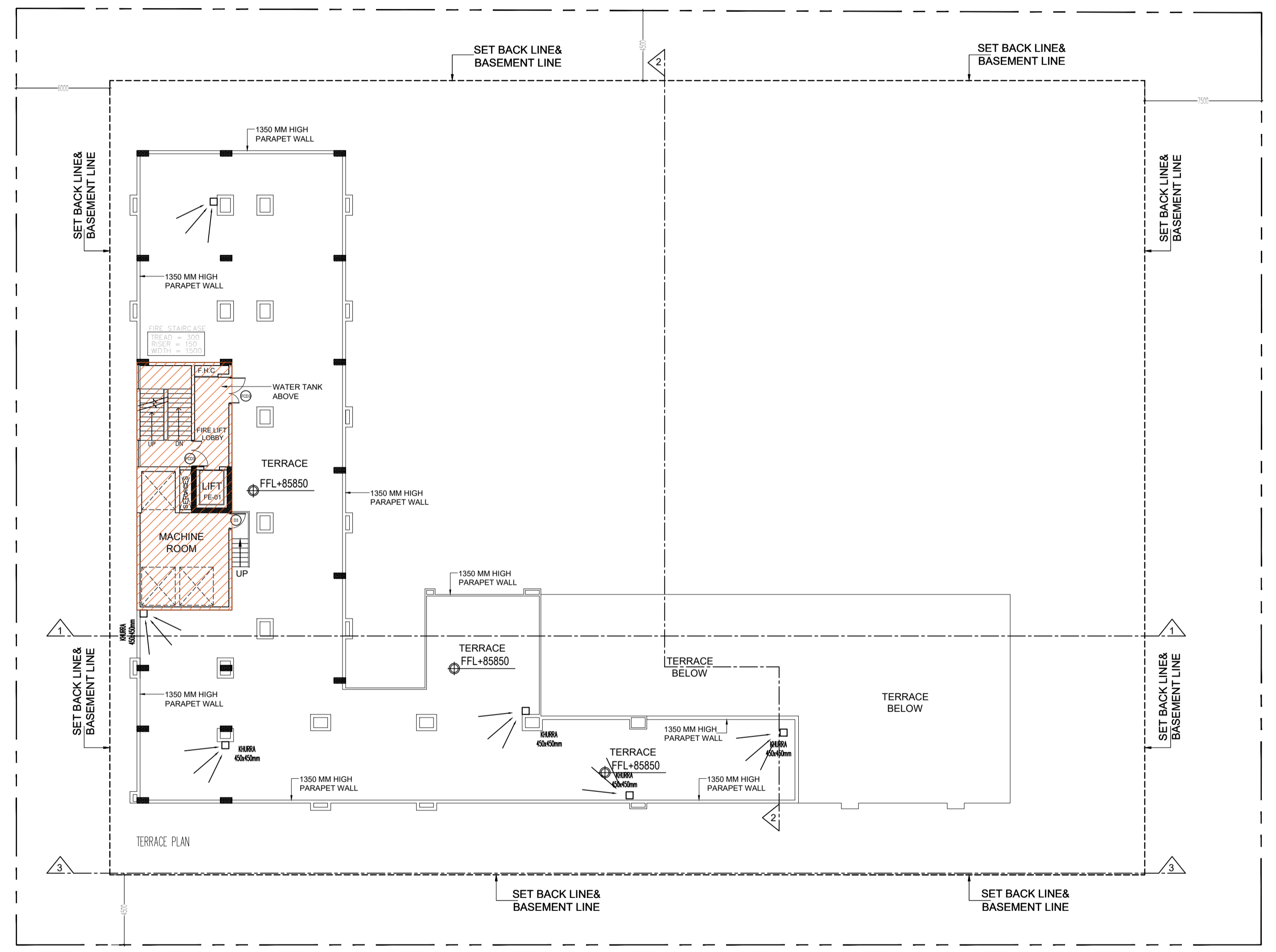

MACHINE ROOM, MUMTY (SERVICE AREA 15%)						
ADDITION AREA						
S. NO.	DIM(m)	X	DIM(m)	FEC.	NOS.	AREA(SQM.)
M01	6.100	X	15.900	1	1	96.990
TOTAL MACHINE ROOM, MUMTY AREA (A)						96.990

WATER TANK AREA (SERVICE AREA 15%)						
S. NO.	DIM(m)	X	DIM(m)	FEC.	NOS.	AREA(SQM.)
W01	6.100	X	7.950	1	1	48.495
TOTAL WATER TANK AREA (B)						48.495
TOTAL NON FAR AREA (A+B)						145.485

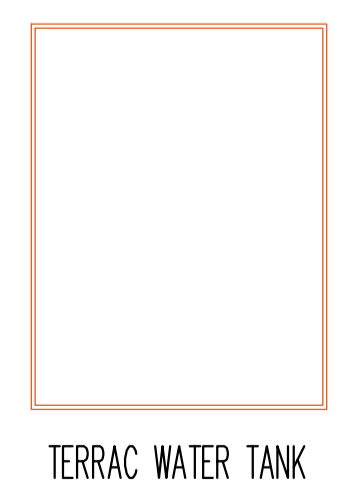

TERRACE WATER TANK

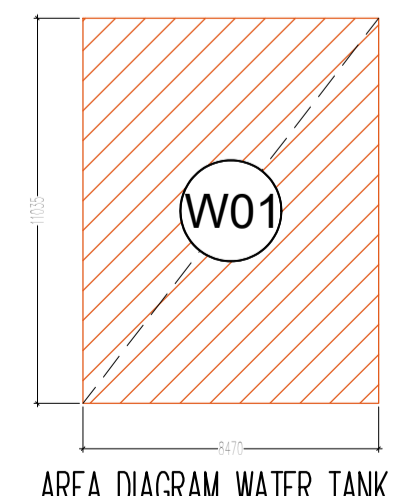

AREA DIAGRAM WATER TANK

TITLE TERRACE PLAN & SECTION 3-3	
PROJECT:- PROPOSED BUILDING PLAN OF COMMERCIAL AT PLOT NO.- C-5 , SECTOR DELTA-I, GREATER NOIDA M/S KAVERI ELITE INFRA DEVELOPERS PVT. LTD	
OWNER 'S SIGNATURE	ARCHITECT 'S SIGNATURE
<b>Girish Kumar Goel</b> Digitally signed by Girish Kumar Goel Date: 2026.01.03 22:46:09 +05'30'	<b>MAHTAB ALAM SAIFI</b> Digitally signed by MAHTAB ALAM SAIFI Date: 2026.01.03 22:49:13 +05'30'

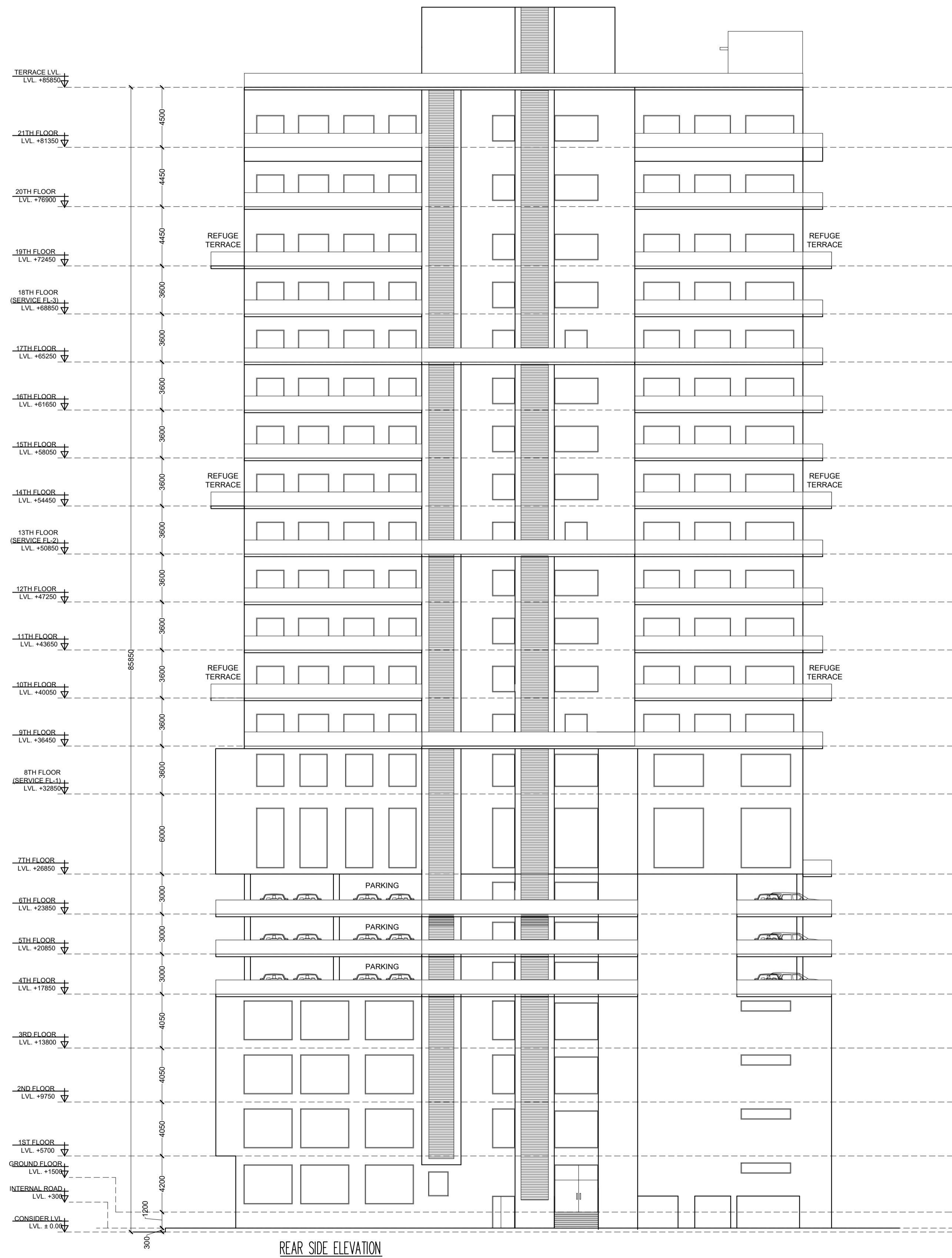

REAR SIDE ELEVATION

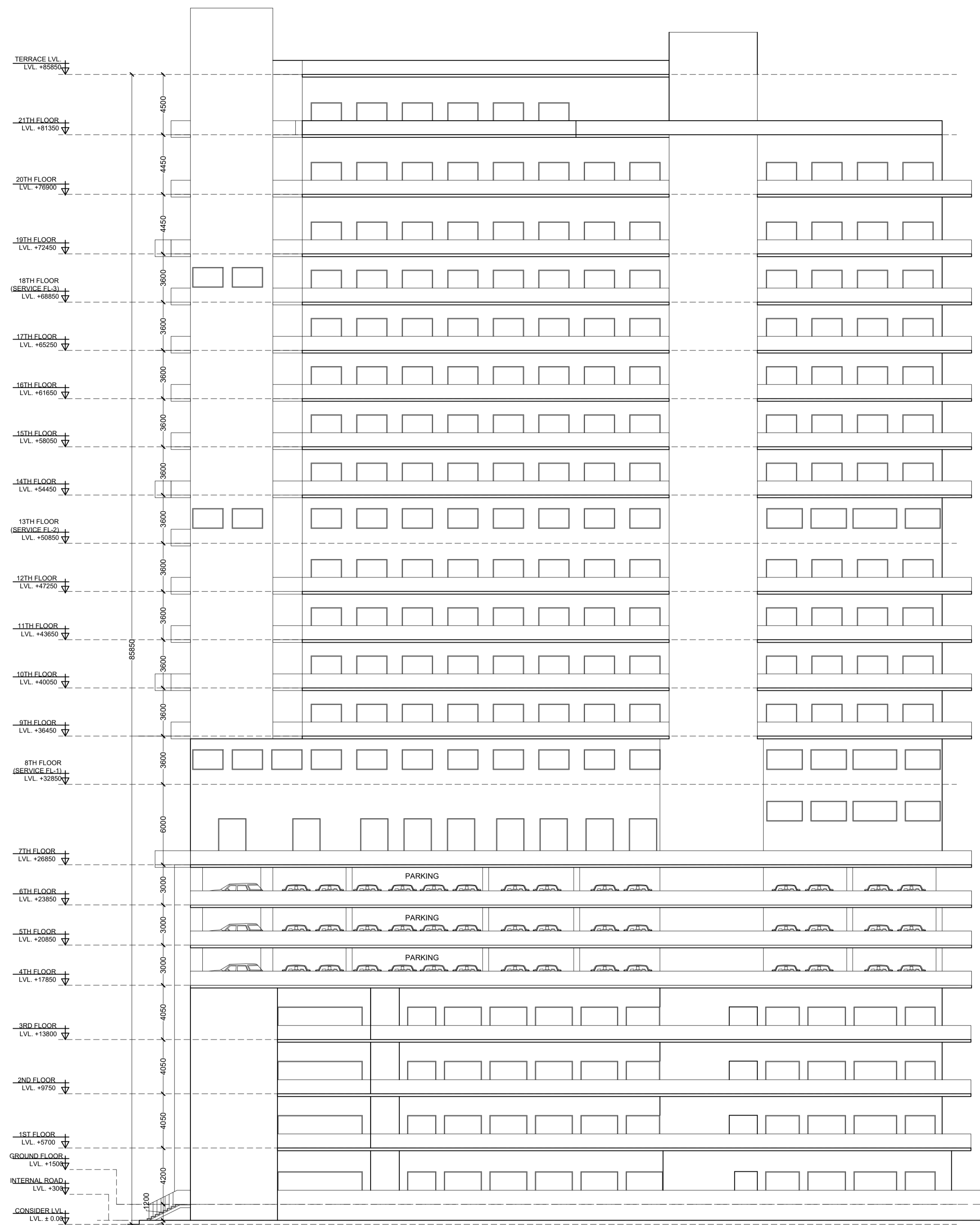

LEFT SIDE ELEVATION

Digitally signed  
By Amit Varma  
Date:  
2026.01.03  
23:40:56  
+05'30'

TITLE REAR AND LEFT SIDE ELEVATION	
PROJECT:- PROPOSED BUILDING PLAN OF COMMERCIAL AT PLOT NO.- C-5 , SECTOR DELTA-I, GREATER NOIDA M/S KAVERI ELITE INFRA DEVELOPERS PVT. LTD	
OWNER 'S SIGNATURE	ARCHITECT 'S SIGNATURE
<p>Digitally signed by Girish Kumar Goel Date: 2026.01.03 22:47:10 +05'30'</p>	<p>Digitally signed by MAHTAB ALAM SAIFI Date: 2026.01.03 22:48:10 +05'30'</p>

**INVENTORY SHEET ( CARPET AREA) OF KAVERI CITY CENTRE-2**

S.No.	Block No	Floor Number ( As per Maps)	Floor Number (As per RERA Portal)	Flat/ Apartment/ Shop/Plot type as Sanctioned Map	Flat/ Apartment/ Shop/Plot type as RERA Portal	Number of Apartment/F lats / Shop	Unit Carpet Area (in sqm)	Number of Balcony	Total Area of Unit + Balcony (in sqm)	Number of Verandah	Total Area of Garrage (in sqm)
1	A	Basement	Basement	Parking	Other	0	0	0	0	0	0
2	A	LOWER GROUND FLOOR	LG	Parking	Other	0	0.00	0	0	0	0
3	A	LOWER GROUND FLOOR	LG	SHOP	SHOP	1	81.94	0	0	0	0
4	A	LOWER GROUND FLOOR	LG	SHOP	SHOP	1	86.21	0	0	0	0
5	A	GROUND FLOOR	Ground	SHOP	SHOP	1	25.16	0	0	0	0
6	A	GROUND FLOOR	Ground	SHOP	SHOP	1	25.39	0	0	0	0
7	A	GROUND FLOOR	Ground	SHOP	SHOP	1	27.06	0	0	0	0
8	A	GROUND FLOOR	Ground	SHOP	SHOP	1	24.56	0	0	0	0
9	A	GROUND FLOOR	Ground	SHOP	SHOP	1	19.05	0	0	0	0
10	A	GROUND FLOOR	Ground	SHOP	SHOP	1	19.03	0	0	0	0
11	A	GROUND FLOOR	Ground	SHOP	SHOP	1	16.31	0	0	0	0
12	A	GROUND FLOOR	Ground	SHOP	SHOP	1	8.88	0	0	0	0
13	A	GROUND FLOOR	Ground	SHOP	SHOP	1	7.33	0	0	0	0
14	A	GROUND FLOOR	Ground	SHOP	SHOP	1	24.90	0	0	0	0
15	A	GROUND FLOOR	Ground	SHOP	SHOP	1	25.52	0	0	0	0
16	A	GROUND FLOOR	Ground	SHOP	SHOP	1	7.12	0	0	0	0
17	A	GROUND FLOOR	Ground	SHOP	SHOP	1	8.21	0	0	0	0
18	A	GROUND FLOOR	Ground	SHOP	SHOP	1	17.57	0	0	0	0
19	A	GROUND FLOOR	Ground	SHOP	SHOP	1	18.35	0	0	0	0
20	A	GROUND FLOOR	Ground	SHOP	SHOP	1	18.35	0	0	0	0
21	A	GROUND FLOOR	Ground	SHOP	SHOP	1	18.35	0	0	0	0
22	A	GROUND FLOOR	Ground	SHOP	SHOP	1	7.65	0	0	0	0
23	A	GROUND FLOOR	Ground	SHOP	SHOP	1	8.55	0	0	0	0
24	A	GROUND FLOOR	Ground	SHOP	SHOP	1	8.55	0	0	0	0
25	A	GROUND FLOOR	Ground	SHOP	SHOP	1	8.55	0	0	0	0
26	A	GROUND FLOOR	Ground	SHOP	SHOP	1	8.54	0	0	0	0
27	A	GROUND FLOOR	Ground	SHOP	SHOP	1	29.08	0	0	0	0
28	A	GROUND FLOOR	Ground	SHOP	SHOP	1	29.08	0	0	0	0
29	A	GROUND FLOOR	Ground	SHOP	SHOP	1	29.08	0	0	0	0
30	A	GROUND FLOOR	Ground	SHOP	SHOP	1	27.84	0	0	0	0
31	A	GROUND FLOOR	Ground	SHOP	SHOP	1	6.63	0	0	0	0
32	A	GROUND FLOOR	Ground	SHOP	SHOP	1	7.05	0	0	0	0
33	A	GROUND FLOOR	Ground	SHOP	SHOP	1	6.95	0	0	0	0

**KAVERI ELITE INFRA DEVELOPERS PVT. LTD.**



**Director**

**INVENTORY SHEET ( CARPET AREA) OF KAVERI CITY CENTRE-2**

S.No.	Block No	Floor Number ( As per Maps)	Floor Number (As per RERA Portal)	Flat/ Apartment/ Shop/Plot type as Sanctioned Map	Flat/ Apartment/ Shop/Plot type as RERA Portal	Number of Apartment/F lats / Shop	Unit Carpet Area (in sqm)	Number of Balcony	Total Area of Unit + Balcony (in sqm)	Number of Verandah	Total Area of Garrage (in sqm)
34	A	GROUND FLOOR	Ground	SHOP	SHOP	1	9.53	0	0	0	0
35	A	GROUND FLOOR	Ground	SHOP	SHOP	1	9.37	0	0	0	0
36	A	GROUND FLOOR	Ground	SHOP	SHOP	1	33.92	0	0	0	0
37	A	GROUND FLOOR	Ground	SHOP	SHOP	1	106.38	0	0	0	0
38	A	GROUND FLOOR	Ground	SHOP	SHOP	1	41.96	0	0	0	0
39	A	GROUND FLOOR	Ground	SHOP	SHOP	1	23.28	0	0	0	0
40	A	GROUND FLOOR	Ground	SHOP	SHOP	1	24.40	0	0	0	0
41	A	GROUND FLOOR	Ground	SHOP	SHOP	1	20.19	0	0	0	0
42	A	GROUND FLOOR	Ground	SHOP	SHOP	1	19.34	0	0	0	0
43	A	GROUND FLOOR	Ground	SHOP	SHOP	1	20.35	0	0	0	0
44	A	GROUND FLOOR	Ground	SHOP	SHOP	1	20.50	0	0	0	0
45	A	GROUND FLOOR	Ground	SHOP	SHOP	1	20.39	0	0	0	0
46	A	GROUND FLOOR	Ground	SHOP	SHOP	1	8.23	0	0	0	0
47	A	GROUND FLOOR	Ground	SHOP	SHOP	1	8.55	0	0	0	0
48	A	GROUND FLOOR	Ground	SHOP	SHOP	1	8.55	0	0	0	0
49	A	GROUND FLOOR	Ground	SHOP	SHOP	1	8.41	0	0	0	0
50	A	GROUND FLOOR	Ground	SHOP	SHOP	1	7.80	0	0	0	0
51	A	GROUND FLOOR	Ground	SHOP	SHOP	1	28.10	0	0	0	0
52	A	GROUND FLOOR	Ground	SHOP	SHOP	1	28.39	0	0	0	0
53	A	GROUND FLOOR	Ground	SHOP	SHOP	1	28.39	0	0	0	0
54	A	GROUND FLOOR	Ground	SHOP	SHOP	1	28.23	0	0	0	0
55	A	GROUND FLOOR	Ground	SHOP	SHOP	1	28.51	0	0	0	0
56	A	GROUND FLOOR	Ground	SHOP	SHOP	1	10.08	0	0	0	0
57	A	GROUND FLOOR	Ground	SHOP	SHOP	1	10.70	0	0	0	0
58	A	GROUND FLOOR	Ground	SHOP	SHOP	1	19.04	0	0	0	0
59	A	GROUND FLOOR	Ground	SHOP	SHOP	1	19.04	0	0	0	0
60	A	GROUND FLOOR	Ground	SHOP	SHOP	1	19.04	0	0	0	0
61	A	GROUND FLOOR	Ground	SHOP	SHOP	1	18.93	0	0	0	0
62	A	GROUND FLOOR	Ground	SHOP	SHOP	1	18.71	0	0	0	0
63	A	GROUND FLOOR	Ground	SHOP	SHOP	1	8.56	0	0	0	0
64	A	GROUND FLOOR	Ground	SHOP	SHOP	1	10.18	0	0	0	0
65	A	GROUND FLOOR	Ground	SHOP	SHOP	1	8.74	0	0	0	0
66	A	GROUND FLOOR	Ground	SHOP	SHOP	1	28.80	0	0	0	0

**KAVERI ELITE INFRA DEVELOPERS PVT. LTD.**

*(Signature)*  
**Director**

INVENTORY SHEET ( CARPET AREA) OF KAVERI CITY CENTRE-2											
S.No.	Block No	Floor Number ( As per Maps)	Floor Number (As per RERA Portal)	Flat/ Apartment/ Shop/Plot type as Sanctioned Map	Flat/ Apartment/ Shop/Plot type as RERA Portal	Number of Apartment/F lats / Shop	Unit Carpet Area (in sqm)	Number of Balcony	Total Area of Unit + Balcony (in sqm)	Number of Verandah	Total Area of Garrage (in sqm)
67	A	GROUND FLOOR	Ground	SHOP	SHOP	1	22.44	0	0	0	0
68	A	GROUND FLOOR	Ground	SHOP	SHOP	1	20.27	0	0	0	0
69	A	GROUND FLOOR	Ground	SHOP	SHOP	1	30.33	0	0	0	0
70	A	GROUND FLOOR	Ground	SHOP	SHOP	1	13.60	0	0	0	0
71	A	GROUND FLOOR	Ground	SHOP	SHOP	1	15.25	0	0	0	0
72	A	GROUND FLOOR	Ground	SHOP	SHOP	1	19.33	0	0	0	0
73	A	GROUND FLOOR	Ground	SHOP	SHOP	1	18.29	0	0	0	0
74	A	1ST FLOOR	1	SHOP	SHOP	1	21.64	0	0	0	0
75	A	1ST FLOOR	1	SHOP	SHOP	1	21.65	0	0	0	0
76	A	1ST FLOOR	1	SHOP	SHOP	1	23.22	0	0	0	0
77	A	1ST FLOOR	1	SHOP	SHOP	1	21.32	0	0	0	0
78	A	1ST FLOOR	1	SHOP	SHOP	1	17.17	0	0	0	0
79	A	1ST FLOOR	1	SHOP	SHOP	1	17.16	0	0	0	0
80	A	1ST FLOOR	1	SHOP	SHOP	1	14.69	0	0	0	0
81	A	1ST FLOOR	1	SHOP	SHOP	1	7.13	0	0	0	0
82	A	1ST FLOOR	1	SHOP	SHOP	1	7.33	0	0	0	0
83	A	1ST FLOOR	1	SHOP	SHOP	1	22.97	0	0	0	0
84	A	1ST FLOOR	1	SHOP	SHOP	1	23.54	0	0	0	0
85	A	1ST FLOOR	1	SHOP	SHOP	1	5.41	0	0	0	0
86	A	1ST FLOOR	1	SHOP	SHOP	1	8.48	0	0	0	0
87	A	1ST FLOOR	1	SHOP	SHOP	1	16.04	0	0	0	0
88	A	1ST FLOOR	1	SHOP	SHOP	1	16.75	0	0	0	0
89	A	1ST FLOOR	1	SHOP	SHOP	1	16.75	0	0	0	0
90	A	1ST FLOOR	1	SHOP	SHOP	1	14.43	0	0	0	0
91	A	1ST FLOOR	1	SHOP	SHOP	1	7.96	0	0	0	0
92	A	1ST FLOOR	1	SHOP	SHOP	1	9.04	0	0	0	0
93	A	1ST FLOOR	1	SHOP	SHOP	1	9.04	0	0	0	0
94	A	1ST FLOOR	1	SHOP	SHOP	1	9.05	0	0	0	0
95	A	1ST FLOOR	1	SHOP	SHOP	1	9.06	0	0	0	0
96	A	1ST FLOOR	1	SHOP	SHOP	1	22.95	0	0	0	0
97	A	1ST FLOOR	1	SHOP	SHOP	1	26.66	0	0	0	0
98	A	1ST FLOOR	1	SHOP	SHOP	1	26.66	0	0	0	0
99	A	1ST FLOOR	1	SHOP	SHOP	1	25.57	0	0	0	0

KAVERI ELITE INFRA  
DEVELOPERS PVT. LTD.

  
Director

INVENTORY SHEET ( CARPET AREA) OF KAVERI CITY CENTRE-2											
S.No.	Block No	Floor Number ( As per Maps)	Floor Number (As per RERA Portal)	Flat/ Apartment/ Shop/Plot type as Sanctioned Map	Flat/ Apartment/ Shop/Plot type as RERA Portal	Number of Apartment/F lats / Shop	Unit Carpet Area (in sqm)	Number of Balcony	Total Area of Unit + Balcony (in sqm)	Number of Verandah	Total Area of Garrage (in sqm)
100	A	1ST FLOOR	1	SHOP	SHOP	1	28.26	0	0	0	0
101	A	1ST FLOOR	1	SHOP	SHOP	1	16.93	0	0	0	0
102	A	1ST FLOOR	1	SHOP	SHOP	1	156.92	0	0	0	0
103	A	1ST FLOOR	1	SHOP	SHOP	1	41.96	0	0	0	0
104	A	1ST FLOOR	1	SHOP	SHOP	1	23.28	0	0	0	0
105	A	1ST FLOOR	1	SHOP	SHOP	1	24.40	0	0	0	0
106	A	1ST FLOOR	1	SHOP	SHOP	1	20.19	0	0	0	0
107	A	1ST FLOOR	1	SHOP	SHOP	1	19.34	0	0	0	0
108	A	1ST FLOOR	1	SHOP	SHOP	1	20.35	0	0	0	0
109	A	1ST FLOOR	1	SHOP	SHOP	1	20.50	0	0	0	0
110	A	1ST FLOOR	1	SHOP	SHOP	1	15.88	0	0	0	0
111	A	1ST FLOOR	1	SHOP	SHOP	1	6.29	0	0	0	0
112	A	1ST FLOOR	1	SHOP	SHOP	1	8.55	0	0	0	0
113	A	1ST FLOOR	1	SHOP	SHOP	1	8.55	0	0	0	0
114	A	1ST FLOOR	1	SHOP	SHOP	1	8.41	0	0	0	0
115	A	1ST FLOOR	1	SHOP	SHOP	1	5.87	0	0	0	0
116	A	1ST FLOOR	1	SHOP	SHOP	1	26.00	0	0	0	0
117	A	1ST FLOOR	1	SHOP	SHOP	1	26.28	0	0	0	0
118	A	1ST FLOOR	1	SHOP	SHOP	1	26.28	0	0	0	0
119	A	1ST FLOOR	1	SHOP	SHOP	1	26.13	0	0	0	0
120	A	1ST FLOOR	1	SHOP	SHOP	1	26.36	0	0	0	0
121	A	1ST FLOOR	1	SHOP	SHOP	1	18.46	0	0	0	0
122	A	1ST FLOOR	1	SHOP	SHOP	1	16.96	0	0	0	0
123	A	1ST FLOOR	1	SHOP	SHOP	1	16.96	0	0	0	0
124	A	1ST FLOOR	1	SHOP	SHOP	1	16.96	0	0	0	0
125	A	1ST FLOOR	1	SHOP	SHOP	1	16.86	0	0	0	0
126	A	1ST FLOOR	1	SHOP	SHOP	1	16.65	0	0	0	0
127	A	1ST FLOOR	1	SHOP	SHOP	1	6.74	0	0	0	0
128	A	1ST FLOOR	1	SHOP	SHOP	1	10.23	0	0	0	0
129	A	1ST FLOOR	1	SHOP	SHOP	1	8.74	0	0	0	0
130	A	1ST FLOOR	1	SHOP	SHOP	1	26.66	0	0	0	0
131	A	1ST FLOOR	1	SHOP	SHOP	1	17.99	0	0	0	0
132	A	1ST FLOOR	1	SHOP	SHOP	1	17.96	0	0	0	0

KAVERI ELITE INFRA  
DEVELOPERS PVT. LTD.



Director

INVENTORY SHEET ( CARPET AREA) OF KAVERI CITY CENTRE-2											
S.No.	Block No	Floor Number ( As per Maps)	Floor Number (As per RERA Portal)	Flat/ Apartment/ Shop/Plot type as Sanctioned Map	Flat/ Apartment/ Shop/Plot type as RERA Portal	Number of Apartment/F lats / Shop	Unit Carpet Area (in sqm)	Number of Balcony	Total Area of Unit + Balcony (in sqm)	Number of Verandah	Total Area of Garrage (in sqm)
133	A	1ST FLOOR	1	SHOP	SHOP	1	28.48	0	0	0	0
134	A	1ST FLOOR	1	SHOP	SHOP	1	11.48	0	0	0	0
135	A	1ST FLOOR	1	SHOP	SHOP	1	11.57	0	0	0	0
136	A	1ST FLOOR	1	SHOP	SHOP	1	17.21	0	0	0	0
137	A	1ST FLOOR	1	SHOP	SHOP	1	16.29	0	0	0	0
138	A	2ND FLOOR	2	SHOP	SHOP	1	21.64	0	0	0	0
139	A	2ND FLOOR	2	SHOP	SHOP	1	21.65	0	0	0	0
140	A	2ND FLOOR	2	SHOP	SHOP	1	23.22	0	0	0	0
141	A	2ND FLOOR	2	SHOP	SHOP	1	21.32	0	0	0	0
142	A	2ND FLOOR	2	SHOP	SHOP	1	17.17	0	0	0	0
143	A	2ND FLOOR	2	SHOP	SHOP	1	17.16	0	0	0	0
144	A	2ND FLOOR	2	SHOP	SHOP	1	14.69	0	0	0	0
145	A	2ND FLOOR	2	SHOP	SHOP	1	7.13	0	0	0	0
146	A	2ND FLOOR	2	SHOP	SHOP	1	7.30	0	0	0	0
147	A	2ND FLOOR	2	SHOP	SHOP	1	22.97	0	0	0	0
148	A	2ND FLOOR	2	SHOP	SHOP	1	23.54	0	0	0	0
149	A	2ND FLOOR	2	SHOP	SHOP	1	5.41	0	0	0	0
150	A	2ND FLOOR	2	SHOP	SHOP	1	8.48	0	0	0	0
151	A	2ND FLOOR	2	SHOP	SHOP	1	16.04	0	0	0	0
152	A	2ND FLOOR	2	SHOP	SHOP	1	16.75	0	0	0	0
153	A	2ND FLOOR	2	SHOP	SHOP	1	16.75	0	0	0	0
154	A	2ND FLOOR	2	SHOP	SHOP	1	14.43	0	0	0	0
155	A	2ND FLOOR	2	SHOP	SHOP	1	7.96	0	0	0	0
156	A	2ND FLOOR	2	SHOP	SHOP	1	9.04	0	0	0	0
157	A	2ND FLOOR	2	SHOP	SHOP	1	9.04	0	0	0	0
158	A	2ND FLOOR	2	SHOP	SHOP	1	9.05	0	0	0	0
159	A	2ND FLOOR	2	SHOP	SHOP	1	9.06	0	0	0	0
160	A	2ND FLOOR	2	SHOP	SHOP	1	22.95	0	0	0	0
161	A	2ND FLOOR	2	SHOP	SHOP	1	26.66	0	0	0	0
162	A	2ND FLOOR	2	SHOP	SHOP	1	26.66	0	0	0	0
163	A	2ND FLOOR	2	SHOP	SHOP	1	25.57	0	0	0	0
164	A	2ND FLOOR	2	SHOP	SHOP	1	28.26	0	0	0	0
165	A	2ND FLOOR	2	SHOP	SHOP	1	16.93	0	0	0	0

KAVERI ELITE INFRA  
DEVELOPERS PVT. LTD.

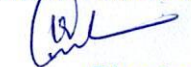

Director

INVENTORY SHEET ( CARPET AREA) OF KAVERI CITY CENTRE-2											
S.No.	Block No	Floor Number ( As per Maps)	Floor Number (As per RERA Portal)	Flat/ Apartment/ Shop/Plot type as Sanctioned Map	Flat/ Apartment/ Shop/Plot type as RERA Portal	Number of Apartment/F lats / Shop	Unit Carpet Area (in sqm)	Number of Balcony	Total Area of Unit + Balcony (in sqm)	Number of Verandah	Total Area of Garrage (in sqm)
166	A	2ND FLOOR	2	SHOP	SHOP	1	156.92	0		0	0
167	A	2ND FLOOR	2	SHOP	SHOP	1	34.01	0		0	0
168	A	2ND FLOOR	2	SHOP	SHOP	1	17.51	0		0	0
169	A	2ND FLOOR	2	SHOP	SHOP	1	15.99	0		0	0
170	A	2ND FLOOR	2	SHOP	SHOP	1	28.56	0		0	0
171	A	2ND FLOOR	2	SHOP	SHOP	1	19.34	0		0	0
172	A	2ND FLOOR	2	SHOP	SHOP	1	20.35	0		0	0
173	A	2ND FLOOR	2	SHOP	SHOP	1	20.50	0		0	0
174	A	2ND FLOOR	2	SHOP	SHOP	1	15.88	0		0	0
175	A	2ND FLOOR	2	SHOP	SHOP	1	6.29	0		0	0
176	A	2ND FLOOR	2	SHOP	SHOP	1	8.55	0		0	0
177	A	2ND FLOOR	2	SHOP	SHOP	1	8.55	0		0	0
178	A	2ND FLOOR	2	SHOP	SHOP	1	8.41	0		0	0
179	A	2ND FLOOR	2	SHOP	SHOP	1	5.87	0		0	0
180	A	2ND FLOOR	2	SHOP	SHOP	1	26.00	0		0	0
181	A	2ND FLOOR	2	SHOP	SHOP	1	26.28	0		0	0
182	A	2ND FLOOR	2	SHOP	SHOP	1	26.28	0		0	0
183	A	2ND FLOOR	2	SHOP	SHOP	1	26.13	0		0	0
184	A	2ND FLOOR	2	SHOP	SHOP	1	26.36	0		0	0
185	A	2ND FLOOR	2	SHOP	SHOP	1	18.51	0		0	0
186	A	2ND FLOOR	2	SHOP	SHOP	1	16.96	0		0	0
187	A	2ND FLOOR	2	SHOP	SHOP	1	16.96	0		0	0
188	A	2ND FLOOR	2	SHOP	SHOP	1	16.96	0		0	0
189	A	2ND FLOOR	2	SHOP	SHOP	1	16.86	0		0	0
190	A	2ND FLOOR	2	SHOP	SHOP	1	16.65	0		0	0
191	A	2ND FLOOR	2	SHOP	SHOP	1	6.74	0		0	0
192	A	2ND FLOOR	2	SHOP	SHOP	1	10.23	0		0	0
193	A	2ND FLOOR	2	SHOP	SHOP	1	8.74	0		0	0
194	A	2ND FLOOR	2	SHOP	SHOP	1	26.66	0		0	0
195	A	2ND FLOOR	2	SHOP	SHOP	1	17.99	0		0	0
196	A	2ND FLOOR	2	SHOP	SHOP	1	17.96	0		0	0
197	A	2ND FLOOR	2	SHOP	SHOP	1	28.48	0		0	0
198	A	2ND FLOOR	2	SHOP	SHOP	1	11.48	0		0	0

KAVERI ELITE INFRA  
DEVELOPERS PVT. LTD.



Director

INVENTORY SHEET ( CARPET AREA) OF KAVERI CITY CENTRE-2											
S.No.	Block No	Floor Number ( As per Maps)	Floor Number (As per RERA Portal)	Flat/ Apartment/ Shop/Plot type as Sanctioned Map	Flat/ Apartment/ Shop/Plot type as RERA Portal	Number of Apartment/F lats / Shop	Unit Carpet Area (in sqm)	Number of Balcony	Total Area of Unit + Balcony (in sqm)	Number of Verandah	Total Area of Garrage (in sqm)
199	A	2ND FLOOR	2	SHOP	SHOP	1	11.57	0		0	0
200	A	2ND FLOOR	2	SHOP	SHOP	1	17.21	0		0	0
201	A	2ND FLOOR	2	SHOP	SHOP	1	16.29	0		0	0
202	A	3RD FLOOR	3	SHOP	SHOP	1	21.64	0		0	0
203	A	3RD FLOOR	3	SHOP	SHOP	1	21.65	0		0	0
204	A	3RD FLOOR	3	SHOP	SHOP	1	23.22	0		0	0
205	A	3RD FLOOR	3	SHOP	SHOP	1	21.32	0		0	0
206	A	3RD FLOOR	3	SHOP	SHOP	1	17.17	0		0	0
207	A	3RD FLOOR	3	SHOP	SHOP	1	17.16	0		0	0
208	A	3RD FLOOR	3	SHOP	SHOP	1	14.69	0		0	0
209	A	3RD FLOOR	3	SHOP	SHOP	1	7.13	0		0	0
210	A	3RD FLOOR	3	SHOP	SHOP	1	7.30	0		0	0
211	A	3RD FLOOR	3	SHOP	SHOP	1	22.97	0		0	0
212	A	3RD FLOOR	3	SHOP	SHOP	1	23.54	0		0	0
213	A	3RD FLOOR	3	SHOP	SHOP	1	5.41	0		0	0
214	A	3RD FLOOR	3	SHOP	SHOP	1	8.48	0		0	0
215	A	3RD FLOOR	3	SHOP	SHOP	1	16.04	0		0	0
216	A	3RD FLOOR	3	SHOP	SHOP	1	16.75	0		0	0
217	A	3RD FLOOR	3	SHOP	SHOP	1	16.75	0		0	0
218	A	3RD FLOOR	3	SHOP	SHOP	1	14.43	0		0	0
219	A	3RD FLOOR	3	SHOP	SHOP	1	7.96	0		0	0
220	A	3RD FLOOR	3	SHOP	SHOP	1	9.04	0		0	0
221	A	3RD FLOOR	3	SHOP	SHOP	1	9.04	0		0	0
222	A	3RD FLOOR	3	SHOP	SHOP	1	9.05	0		0	0
223	A	3RD FLOOR	3	SHOP	SHOP	1	9.06	0		0	0
224	A	3RD FLOOR	3	SHOP	SHOP	1	22.95	0		0	0
225	A	3RD FLOOR	3	SHOP	SHOP	1	26.66	0		0	0
226	A	3RD FLOOR	3	SHOP	SHOP	1	26.66	0		0	0
227	A	3RD FLOOR	3	SHOP	SHOP	1	25.57	0		0	0
228	A	3RD FLOOR	3	SHOP	SHOP	1	28.26	0		0	0
229	A	3RD FLOOR	3	SHOP	SHOP	1	16.93	0		0	0
230	A	3RD FLOOR	3	SHOP	SHOP	1	156.92	0		0	0
231	A	3RD FLOOR	3	SHOP	SHOP	1	34.01	0		0	0

KAVERI ELITE INFRA  
DEVELOPERS PVT. LTD.



Director

INVENTORY SHEET ( CARPET AREA) OF KAVERI CITY CENTRE-2											
S.No.	Block No	Floor Number ( As per Maps)	Floor Number (As per RERA Portal)	Flat/ Apartment/ Shop/Plot type as Sanctioned Map	Flat/ Apartment/ Shop/Plot type as RERA Portal	Number of Apartment/F lats / Shop	Unit Carpet Area (in sqm)	Number of Balcony	Total Area of Unit + Balcony (in sqm)	Number of Verandah	Total Area of Garrage (in sqm)
232	A	3RD FLOOR	3	SHOP	SHOP	1	17.51	0		0	0
233	A	3RD FLOOR	3	SHOP	SHOP	1	15.99	0		0	0
234	A	3RD FLOOR	3	SHOP	SHOP	1	28.56	0		0	0
235	A	3RD FLOOR	3	SHOP	SHOP	1	19.34	0		0	0
236	A	3RD FLOOR	3	SHOP	SHOP	1	20.35	0		0	0
237	A	3RD FLOOR	3	SHOP	SHOP	1	20.50	0		0	0
238	A	3RD FLOOR	3	SHOP	SHOP	1	15.88	0		0	0
239	A	3RD FLOOR	3	SHOP	SHOP	1	6.29	0		0	0
240	A	3RD FLOOR	3	SHOP	SHOP	1	8.55	0		0	0
241	A	3RD FLOOR	3	SHOP	SHOP	1	8.55	0		0	0
242	A	3RD FLOOR	3	SHOP	SHOP	1	8.41	0		0	0
243	A	3RD FLOOR	3	SHOP	SHOP	1	5.87	0		0	0
244	A	3RD FLOOR	3	SHOP	SHOP	1	26.00	0		0	0
245	A	3RD FLOOR	3	SHOP	SHOP	1	26.28	0		0	0
246	A	3RD FLOOR	3	SHOP	SHOP	1	26.28	0		0	0
247	A	3RD FLOOR	3	SHOP	SHOP	1	26.13	0		0	0
248	A	3RD FLOOR	3	SHOP	SHOP	1	26.36	0		0	0
249	A	3RD FLOOR	3	SHOP	SHOP	1	18.51	0		0	0
250	A	3RD FLOOR	3	SHOP	SHOP	1	16.96	0		0	0
251	A	3RD FLOOR	3	SHOP	SHOP	1	16.96	0		0	0
252	A	3RD FLOOR	3	SHOP	SHOP	1	16.96	0		0	0
253	A	3RD FLOOR	3	SHOP	SHOP	1	16.86	0		0	0
254	A	3RD FLOOR	3	SHOP	SHOP	1	16.65	0		0	0
255	A	3RD FLOOR	3	SHOP	SHOP	1	6.74	0		0	0
256	A	3RD FLOOR	3	SHOP	SHOP	1	10.23	0		0	0
257	A	3RD FLOOR	3	SHOP	SHOP	1	8.74	0		0	0
258	A	3RD FLOOR	3	SHOP	SHOP	1	26.66	0		0	0
259	A	3RD FLOOR	3	SHOP	SHOP	1	17.99	0		0	0
260	A	3RD FLOOR	3	SHOP	SHOP	1	17.96	0		0	0
261	A	3RD FLOOR	3	SHOP	SHOP	1	28.48	0		0	0
262	A	3RD FLOOR	3	SHOP	SHOP	1	11.48	0		0	0
263	A	3RD FLOOR	3	SHOP	SHOP	1	11.57	0		0	0
264	A	3RD FLOOR	3	SHOP	SHOP	1	17.21	0		0	0

KAVERI ELITE INFRA  
DEVELOPERS PVT. LTD.

  
Director

INVENTORY SHEET ( CARPET AREA) OF KAVERI CITY CENTRE-2											
S.No.	Block No	Floor Number ( As per Maps)	Floor Number (As per RERA Portal)	Flat/ Apartment/ Shop/Plot type as Sanctioned Map	Flat/ Apartment/ Shop/Plot type as RERA Portal	Number of Apartment/F lats / Shop	Unit Carpet Area (in sqm)	Number of Balcony	Total Area of Unit + Balcony (in sqm)	Number of Verandah	Total Area of Garrage (in sqm)
265	A	3RD FLOOR	3	SHOP	SHOP	1	16.29	0		0	0
266	A	4th Floor	4	Multi-Level Car Parking	Other	0	0.00	0	0	0	0
267	A	5th Floor	5	Multi-Level Car Parking	Other	0	0.00	0	0	0	0
268	A	6th Floor	6	Multi-Level Car Parking	Other	0	0	0	0	0	0
269	A	7TH FLOOR	7	RESTAURANT	Other	1	222.96	0		0	0
270	A	7TH FLOOR	7	OFFICE	Other	1	25.83	0		0	0
271	A	7TH FLOOR	7	RESTAURANT	Other	1	244.67	0		0	0
272	A	7TH FLOOR	7	RESTAURANT	Other	1	190.21	0		0	0
273	A	7TH FLOOR	7	RESTAURANT	Other	1	172.39	0		0	0
274	A	Service Floor 1	8	Service Floor	Other	0	0	0	0	0	0
275	A	8TH FLOOR	9	ROOM	STUDIO	1	16.74	5.14	21.88	0	0
276	A	8TH FLOOR	9	ROOM	STUDIO	1	16.78	4.99	21.77	0	0
277	A	8TH FLOOR	9	ROOM	STUDIO	1	16.78	4.99	21.77	0	0
278	A	8TH FLOOR	9	ROOM	STUDIO	1	16.71	4.99	21.70	0	0
279	A	8TH FLOOR	9	ROOM	STUDIO	1	16.82	4.99	21.81	0	0
280	A	8TH FLOOR	9	ROOM	STUDIO	1	16.79	4.99	21.78	0	0
281	A	8TH FLOOR	9	ROOM	STUDIO	1	16.76	4.99	21.75	0	0
282	A	8TH FLOOR	9	ROOM	STUDIO	1	16.78	4.99	21.77	0	0
283	A	8TH FLOOR	9	ROOM	STUDIO	1	16.78	4.99	21.77	0	0
284	A	8TH FLOOR	9	ROOM	STUDIO	1	16.74	5.14	21.88	0	0
285	A	8TH FLOOR	9	ROOM	STUDIO	1	18.33	5.11	23.44	0	0
286	A	8TH FLOOR	9	ROOM	STUDIO	1	18.33	4.99	23.32	0	0
287	A	8TH FLOOR	9	ROOM	STUDIO	1	18.33	4.99	23.32	0	0
288	A	8TH FLOOR	9	ROOM	STUDIO	1	18.33	4.99	23.32	0	0
289	A	8TH FLOOR	9	ROOM	STUDIO	1	18.24	4.99	23.23	0	0
290	A	8TH FLOOR	9	ROOM	STUDIO	1	18.42	4.99	23.41	0	0
291	A	8TH FLOOR	9	ROOM	STUDIO	1	18.42	4.99	23.41	0	0
292	A	8TH FLOOR	9	ROOM	STUDIO	1	18.32	4.99	23.31	0	0
293	A	8TH FLOOR	9	ROOM	STUDIO	1	18.33	4.99	23.32	0	0
294	A	8TH FLOOR	9	ROOM	STUDIO	1	18.33	4.99	23.32	0	0
295	A	8TH FLOOR	9	ROOM	STUDIO	1	18.24	5.14	23.38	0	0
296	A	8TH FLOOR	9	ROOM	STUDIO	1	16.74	5.14	21.88	0	0
297	A	8TH FLOOR	9	ROOM	STUDIO	1	16.78	4.99	21.77	0	0

INVENTORY SHEET ( CARPET AREA) OF KAVERI CITY CENTRE-2											
S.No.	Block No	Floor Number ( As per Maps)	Floor Number (As per RERA Portal)	Flat/ Apartment/ Shop/Plot type as Sanctioned Map	Flat/ Apartment/ Shop/Plot type as RERA Portal	Number of Apartment/F lats / Shop	Unit Carpet Area (in sqm)	Number of Balcony	Total Area of Unit + Balcony (in sqm)	Number of Verandah	Total Area of Garrage (in sqm)
298	A	8TH FLOOR	9	ROOM	STUDIO	1	16.78	4.99	21.77	0	0
299	A	8TH FLOOR	9	ROOM	STUDIO	1	16.64	5.14	21.78	0	0
300	A	8TH FLOOR	9	ROOM	STUDIO	1	16.64	5.14	21.78	0	0
301	A	8TH FLOOR	9	ROOM	STUDIO	1	16.78	4.99	21.77	0	0
302	A	8TH FLOOR	9	ROOM	STUDIO	1	16.78	4.99	21.77	0	0
303	A	8TH FLOOR	9	ROOM	STUDIO	1	16.78	4.99	21.77	0	0
304	A	8TH FLOOR	9	ROOM	STUDIO	1	16.78	4.99	21.77	0	0
305	A	8TH FLOOR	9	ROOM	STUDIO	1	16.82	4.99	21.81	0	0
306	A	8TH FLOOR	9	ROOM	STUDIO	1	16.78	4.99	21.77	0	0
307	A	8TH FLOOR	9	ROOM	STUDIO	1	16.78	5.14	21.92	0	0
308	A	8TH FLOOR	9	ROOM	STUDIO	1	26.03	7.14	33.17	0	0
309	A	8TH FLOOR	9	ROOM	STUDIO	1	20.89	5.63	26.52	0	0
310	A	8TH FLOOR	9	ROOM	STUDIO	1	20.89	5.78	26.67	0	0
311	A	8TH FLOOR	9	ROOM	STUDIO	1	18.18	5.14	23.32	0	0
312	A	8TH FLOOR	9	ROOM	STUDIO	1	18.33	4.99	23.32	0	0
313	A	8TH FLOOR	9	ROOM	STUDIO	1	18.33	4.99	23.32	0	0
314	A	8TH FLOOR	9	ROOM	STUDIO	1	18.24	5.14	23.38	0	0
315	A	9TH FLOOR	10	ROOM	STUDIO	1	16.74	5.14	21.88	0	0
316	A	9TH FLOOR	10	ROOM	STUDIO	1	16.78	4.99	21.77	0	0
317	A	9TH FLOOR	10	ROOM	STUDIO	1	16.78	4.99	21.77	0	0
318	A	9TH FLOOR	10	ROOM	STUDIO	1	16.71	4.99	21.70	0	0
319	A	9TH FLOOR	10	ROOM	STUDIO	1	16.82	4.99	21.81	0	0
320	A	9TH FLOOR	10	ROOM	STUDIO	1	16.79	4.99	21.78	0	0
321	A	9TH FLOOR	10	ROOM	STUDIO	1	16.76	4.99	21.75	0	0
322	A	9TH FLOOR	10	ROOM	STUDIO	1	16.78	4.99	21.77	0	0
323	A	9TH FLOOR	10	ROOM	STUDIO	1	16.78	4.99	21.77	0	0
324	A	9TH FLOOR	10	ROOM	STUDIO	1	16.74	5.14	21.88	0	0
325	A	9TH FLOOR	10	ROOM	STUDIO	1	18.33	5.11	23.44	0	0
326	A	9TH FLOOR	10	ROOM	STUDIO	1	18.33	4.99	23.32	0	0
327	A	9TH FLOOR	10	ROOM	STUDIO	1	18.33	4.99	23.32	0	0
328	A	9TH FLOOR	10	ROOM	STUDIO	1	18.33	4.99	23.32	0	0
329	A	9TH FLOOR	10	ROOM	STUDIO	1	18.24	4.99	23.23	0	0
330	A	9TH FLOOR	10	ROOM	STUDIO	1	18.42	4.99	23.41	0	0

KAVERI ELITE INFRA  
DEVELOPERS PVT. LTD.

  
Director

INVENTORY SHEET ( CARPET AREA) OF KAVERI CITY CENTRE-2											
S.No.	Block No	Floor Number ( As per Maps)	Floor Number (As per RERA Portal)	Flat/ Apartment/ Shop/Plot type as Sanctioned Map	Flat/ Apartment/ Shop/Plot type as RERA Portal	Number of Apartment/F lats / Shop	Unit Carpet Area (in sqm)	Number of Balcony	Total Area of Unit + Balcony (in sqm)	Number of Verandah	Total Area of Garrage (in sqm)
331	A	9TH FLOOR	10	ROOM	STUDIO	1	18.42	4.99	23.41	0	0
332	A	9TH FLOOR	10	ROOM	STUDIO	1	18.32	4.99	23.31	0	0
333	A	9TH FLOOR	10	ROOM	STUDIO	1	18.33	4.99	23.32	0	0
334	A	9TH FLOOR	10	ROOM	STUDIO	1	18.33	4.99	23.32	0	0
335	A	9TH FLOOR	10	ROOM	STUDIO	1	18.24	5.14	23.38	0	0
336	A	9TH FLOOR	10	ROOM	STUDIO	1	16.74	5.14	21.88	0	0
337	A	9TH FLOOR	10	ROOM	STUDIO	1	16.78	4.99	21.77	0	0
338	A	9TH FLOOR	10	ROOM	STUDIO	1	16.78	4.99	21.77	0	0
339	A	9TH FLOOR	10	ROOM	STUDIO	1	16.64	5.14	21.78	0	0
340	A	9TH FLOOR	10	ROOM	STUDIO	1	16.64	5.14	21.78	0	0
341	A	9TH FLOOR	10	ROOM	STUDIO	1	16.78	4.99	21.77	0	0
342	A	9TH FLOOR	10	ROOM	STUDIO	1	16.78	4.99	21.77	0	0
343	A	9TH FLOOR	10	ROOM	STUDIO	1	16.78	4.99	21.77	0	0
344	A	9TH FLOOR	10	ROOM	STUDIO	1	16.78	4.99	21.77	0	0
345	A	9TH FLOOR	10	ROOM	STUDIO	1	16.82	4.99	21.81	0	0
346	A	9TH FLOOR	10	ROOM	STUDIO	1	16.78	4.99	21.77	0	0
347	A	9TH FLOOR	10	ROOM	STUDIO	1	16.78	5.14	21.92	0	0
348	A	9TH FLOOR	10	ROOM	STUDIO	1	20.66	7.14	27.80	0	0
349	A	9TH FLOOR	10	ROOM	STUDIO	1	20.89	5.63	26.52	0	0
350	A	9TH FLOOR	10	ROOM	STUDIO	1	20.89	5.78	26.67	0	0
351	A	9TH FLOOR	10	ROOM	STUDIO	1	18.18	5.14	23.32	0	0
352	A	9TH FLOOR	10	ROOM	STUDIO	1	18.33	4.99	23.32	0	0
353	A	9TH FLOOR	10	ROOM	STUDIO	1	18.33	4.99	23.32	0	0
354	A	9TH FLOOR	10	ROOM	STUDIO	1	18.24	5.14	23.38	0	0
355	A	10TH FLOOR	11	ROOM	STUDIO	1	16.74	5.14	21.88	0	0
356	A	10TH FLOOR	11	ROOM	STUDIO	1	16.78	4.99	21.77	0	0
357	A	10TH FLOOR	11	ROOM	STUDIO	1	16.78	4.99	21.77	0	0
358	A	10TH FLOOR	11	ROOM	STUDIO	1	16.71	4.99	21.70	0	0
359	A	10TH FLOOR	11	ROOM	STUDIO	1	16.82	4.99	21.81	0	0
360	A	10TH FLOOR	11	ROOM	STUDIO	1	16.79	4.99	21.78	0	0
361	A	10TH FLOOR	11	ROOM	STUDIO	1	16.76	4.99	21.75	0	0
362	A	10TH FLOOR	11	ROOM	STUDIO	1	16.78	4.99	21.77	0	0
363	A	10TH FLOOR	11	ROOM	STUDIO	1	16.78	4.99	21.77	0	0

KAVERI ELITE INFRA  
DEVELOPERS PVT. LTD.

Director

**INVENTORY SHEET ( CARPET AREA) OF KAVERI CITY CENTRE-2**

S.No.	Block No	Floor Number ( As per Maps)	Floor Number (As per RERA Portal)	Flat/ Apartment/ Shop/Plot type as Sanctioned Map	Flat/ Apartment/ Shop/Plot type as RERA Portal	Number of Apartment/F lats / Shop	Unit Carpet Area (in sqm)	Number of Balcony	Total Area of Unit + Balcony (in sqm)	Number of Verandah	Total Area of Garrage (in sqm)
364	A	10TH FLOOR	11	ROOM	STUDIO	1	16.74	5.14	21.88	0	0
365	A	10TH FLOOR	11	ROOM	STUDIO	1	18.33	5.11	23.44	0	0
366	A	10TH FLOOR	11	ROOM	STUDIO	1	18.33	4.99	23.32	0	0
367	A	10TH FLOOR	11	ROOM	STUDIO	1	18.33	4.99	23.32	0	0
368	A	10TH FLOOR	11	ROOM	STUDIO	1	18.33	4.99	23.32	0	0
369	A	10TH FLOOR	11	ROOM	STUDIO	1	18.24	4.99	23.23	0	0
370	A	10TH FLOOR	11	ROOM	STUDIO	1	18.42	4.99	23.41	0	0
371	A	10TH FLOOR	11	ROOM	STUDIO	1	18.42	4.99	23.41	0	0
372	A	10TH FLOOR	11	ROOM	STUDIO	1	18.32	4.99	23.31	0	0
373	A	10TH FLOOR	11	ROOM	STUDIO	1	18.33	4.99	23.32	0	0
374	A	10TH FLOOR	11	ROOM	STUDIO	1	18.33	4.99	23.32	0	0
375	A	10TH FLOOR	11	ROOM	STUDIO	1	18.24	5.14	23.38	0	0
376	A	10TH FLOOR	11	ROOM	STUDIO	1	16.74	5.14	21.88	0	0
377	A	10TH FLOOR	11	ROOM	STUDIO	1	16.78	4.99	21.77	0	0
378	A	10TH FLOOR	11	ROOM	STUDIO	1	16.78	4.99	21.77	0	0
379	A	10TH FLOOR	11	ROOM	STUDIO	1	16.64	5.14	21.78	0	0
380	A	10TH FLOOR	11	ROOM	STUDIO	1	16.64	5.14	21.78	0	0
381	A	10TH FLOOR	11	ROOM	STUDIO	1	16.78	4.99	21.77	0	0
382	A	10TH FLOOR	11	ROOM	STUDIO	1	16.78	4.99	21.77	0	0
383	A	10TH FLOOR	11	ROOM	STUDIO	1	16.78	4.99	21.77	0	0
384	A	10TH FLOOR	11	ROOM	STUDIO	1	16.78	4.99	21.77	0	0
385	A	10TH FLOOR	11	ROOM	STUDIO	1	16.82	4.99	21.81	0	0
386	A	10TH FLOOR	11	ROOM	STUDIO	1	16.78	4.99	21.77	0	0
387	A	10TH FLOOR	11	ROOM	STUDIO	1	16.78	5.14	21.92	0	0
388	A	10TH FLOOR	11	ROOM	STUDIO	1	26.03	7.14	33.17	0	0
389	A	10TH FLOOR	11	ROOM	STUDIO	1	20.89	5.63	26.52	0	0
390	A	10TH FLOOR	11	ROOM	STUDIO	1	20.89	5.78	26.67	0	0
391	A	10TH FLOOR	11	ROOM	STUDIO	1	18.18	5.14	23.32	0	0
392	A	10TH FLOOR	11	ROOM	STUDIO	1	18.33	4.99	23.32	0	0
393	A	10TH FLOOR	11	ROOM	STUDIO	1	18.33	4.99	23.32	0	0
394	A	10TH FLOOR	11	ROOM	STUDIO	1	18.24	5.14	23.38	0	0
395	A	Service Floor 2	12	Service Floor	Other	0	0	0	0	0	0
396	A	11TH FLOOR	13	ROOM	STUDIO	1	16.74	5.14	21.88	0	0

**KAVERI ELITE INFRA DEVELOPERS PVT. LTD.**

*(Signature)*  
**Director**

**INVENTORY SHEET ( CARPET AREA) OF KAVERI CITY CENTRE-2**

S.No.	Block No	Floor Number ( As per Maps)	Floor Number (As per RERA Portal)	Flat/ Apartment/ Shop/Plot type as Sanctioned Map	Flat/ Apartment/ Shop/Plot type as RERA Portal	Number of Apartment/F lats / Shop	Unit Carpet Area (in sqm)	Number of Balcony	Total Area of Unit + Balcony (in sqm)	Number of Verandah	Total Area of Garrage (in sqm)
397	A	11TH FLOOR	13	ROOM	STUDIO	1	16.78	4.99	21.77	0	0
398	A	11TH FLOOR	13	ROOM	STUDIO	1	16.78	4.99	21.77	0	0
399	A	11TH FLOOR	13	ROOM	STUDIO	1	16.71	4.99	21.70	0	0
400	A	11TH FLOOR	13	ROOM	STUDIO	1	16.82	4.99	21.81	0	0
401	A	11TH FLOOR	13	ROOM	STUDIO	1	16.79	4.99	21.78	0	0
402	A	11TH FLOOR	13	ROOM	STUDIO	1	16.76	4.99	21.75	0	0
403	A	11TH FLOOR	13	ROOM	STUDIO	1	16.78	4.99	21.77	0	0
404	A	11TH FLOOR	13	ROOM	STUDIO	1	16.78	4.99	21.77	0	0
405	A	11TH FLOOR	13	ROOM	STUDIO	1	16.74	5.14	21.88	0	0
406	A	11TH FLOOR	13	ROOM	STUDIO	1	18.33	5.11	23.44	0	0
407	A	11TH FLOOR	13	ROOM	STUDIO	1	18.33	4.99	23.32	0	0
408	A	11TH FLOOR	13	ROOM	STUDIO	1	18.33	4.99	23.32	0	0
409	A	11TH FLOOR	13	ROOM	STUDIO	1	18.33	4.99	23.32	0	0
410	A	11TH FLOOR	13	ROOM	STUDIO	1	18.33	4.99	23.32	0	0
411	A	11TH FLOOR	13	ROOM	STUDIO	1	18.24	4.99	23.23	0	0
412	A	11TH FLOOR	13	ROOM	STUDIO	1	18.42	4.99	23.41	0	0
413	A	11TH FLOOR	13	ROOM	STUDIO	1	18.42	4.99	23.41	0	0
414	A	11TH FLOOR	13	ROOM	STUDIO	1	18.32	4.99	23.31	0	0
415	A	11TH FLOOR	13	ROOM	STUDIO	1	18.33	4.99	23.32	0	0
416	A	11TH FLOOR	13	ROOM	STUDIO	1	18.33	4.99	23.32	0	0
417	A	11TH FLOOR	13	ROOM	STUDIO	1	18.24	5.14	23.38	0	0
418	A	11TH FLOOR	13	ROOM	STUDIO	1	16.74	5.14	21.88	0	0
419	A	11TH FLOOR	13	ROOM	STUDIO	1	16.78	4.99	21.77	0	0
420	A	11TH FLOOR	13	ROOM	STUDIO	1	16.78	4.99	21.77	0	0
421	A	11TH FLOOR	13	ROOM	STUDIO	1	16.64	5.14	21.78	0	0
422	A	11TH FLOOR	13	ROOM	STUDIO	1	16.64	5.14	21.78	0	0
423	A	11TH FLOOR	13	ROOM	STUDIO	1	16.78	4.99	21.77	0	0
424	A	11TH FLOOR	13	ROOM	STUDIO	1	16.78	4.99	21.77	0	0
425	A	11TH FLOOR	13	ROOM	STUDIO	1	16.78	4.99	21.77	0	0
426	A	11TH FLOOR	13	ROOM	STUDIO	1	16.78	4.99	21.77	0	0
427	A	11TH FLOOR	13	ROOM	STUDIO	1	16.82	4.99	21.81	0	0
428	A	11TH FLOOR	13	ROOM	STUDIO	1	16.78	4.99	21.77	0	0
429	A	11TH FLOOR	13	ROOM	STUDIO	1	16.78	5.14	21.92	0	0
							26.03	7.14	33.17	0	0

**KAVERI ELITE INFRA DEVELOPERS PVT. LTD.**

*(Signature)*

**Director**

INVENTORY SHEET ( CARPET AREA) OF KAVERI CITY CENTRE-2											
S.No.	Block No	Floor Number ( As per Maps)	Floor Number (As per RERA Portal)	Flat/ Apartment/ Shop/Plot type as Sanctioned Map	Flat/ Apartment/ Shop/Plot type as RERA Portal	Number of Apartment/F lats / Shop	Unit Carpet Area (in sqm)	Number of Balcony	Total Area of Unit + Balcony (in sqm)	Number of Verandah	Total Area of Garrage (in sqm)
430	A	11TH FLOOR	13	ROOM	STUDIO	1	20.89	5.63	26.52	0	0
431	A	11TH FLOOR	13	ROOM	STUDIO	1	20.89	5.78	26.67	0	0
432	A	11TH FLOOR	13	ROOM	STUDIO	1	18.18	5.14	23.32	0	0
433	A	11TH FLOOR	13	ROOM	STUDIO	1	18.33	4.99	23.32	0	0
434	A	11TH FLOOR	13	ROOM	STUDIO	1	18.33	4.99	23.32	0	0
435	A	11TH FLOOR	13	ROOM	STUDIO	1	18.24	5.14	23.38	0	0
436	A	12TH FLOOR	14	ROOM	STUDIO	1	16.74	5.14	21.88	0	0
437	A	12TH FLOOR	14	ROOM	STUDIO	1	16.78	4.99	21.77	0	0
438	A	12TH FLOOR	14	ROOM	STUDIO	1	16.78	4.99	21.77	0	0
439	A	12TH FLOOR	14	ROOM	STUDIO	1	16.71	4.99	21.70	0	0
440	A	12TH FLOOR	14	ROOM	STUDIO	1	16.82	4.99	21.81	0	0
441	A	12TH FLOOR	14	ROOM	STUDIO	1	16.79	4.99	21.78	0	0
442	A	12TH FLOOR	14	ROOM	STUDIO	1	16.76	4.99	21.75	0	0
443	A	12TH FLOOR	14	ROOM	STUDIO	1	16.78	4.99	21.77	0	0
444	A	12TH FLOOR	14	ROOM	STUDIO	1	16.78	4.99	21.77	0	0
445	A	12TH FLOOR	14	ROOM	STUDIO	1	16.74	5.14	21.88	0	0
446	A	12TH FLOOR	14	ROOM	STUDIO	1	18.33	5.11	23.44	0	0
447	A	12TH FLOOR	14	ROOM	STUDIO	1	18.33	4.99	23.32	0	0
448	A	12TH FLOOR	14	ROOM	STUDIO	1	18.33	4.99	23.32	0	0
449	A	12TH FLOOR	14	ROOM	STUDIO	1	18.33	4.99	23.32	0	0
450	A	12TH FLOOR	14	ROOM	STUDIO	1	18.24	4.99	23.23	0	0
451	A	12TH FLOOR	14	ROOM	STUDIO	1	18.42	4.99	23.41	0	0
452	A	12TH FLOOR	14	ROOM	STUDIO	1	18.42	4.99	23.41	0	0
453	A	12TH FLOOR	14	ROOM	STUDIO	1	18.32	4.99	23.31	0	0
454	A	12TH FLOOR	14	ROOM	STUDIO	1	18.33	4.99	23.32	0	0
455	A	12TH FLOOR	14	ROOM	STUDIO	1	18.33	4.99	23.32	0	0
456	A	12TH FLOOR	14	ROOM	STUDIO	1	18.24	5.14	23.38	0	0
457	A	12TH FLOOR	14	ROOM	STUDIO	1	16.74	5.14	21.88	0	0
458	A	12TH FLOOR	14	ROOM	STUDIO	1	16.78	4.99	21.77	0	0
459	A	12TH FLOOR	14	ROOM	STUDIO	1	16.78	4.99	21.77	0	0
460	A	12TH FLOOR	14	ROOM	STUDIO	1	16.64	5.14	21.78	0	0
461	A	12TH FLOOR	14	ROOM	STUDIO	1	16.64	5.14	21.78	0	0
462	A	12TH FLOOR	14	ROOM	STUDIO	1	16.78	4.99	21.77	0	0

**INVENTORY SHEET ( CARPET AREA) OF KAVERI CITY CENTRE-2**

S.No.	Block No	Floor Number ( As per Maps)	Floor Number (As per RERA Portal)	Flat/ Apartment/ Shop/Plot type as Sanctioned Map	Flat/ Apartment/ Shop/Plot type as RERA Portal	Number of Apartment/F lats / Shop	Unit Carpet Area (in sqm)	Number of Balcony	Total Area of Unit + Balcony (in sqm)	Number of Verandah	Total Area of Garrage (in sqm)
463	A	12TH FLOOR	14	ROOM	STUDIO	1	16.78	4.99	21.77	0	0
464	A	12TH FLOOR	14	ROOM	STUDIO	1	16.78	4.99	21.77	0	0
465	A	12TH FLOOR	14	ROOM	STUDIO	1	16.78	4.99	21.77	0	0
466	A	12TH FLOOR	14	ROOM	STUDIO	1	16.82	4.99	21.81	0	0
467	A	12TH FLOOR	14	ROOM	STUDIO	1	16.78	4.99	21.77	0	0
468	A	12TH FLOOR	14	ROOM	STUDIO	1	16.78	5.14	21.92	0	0
469	A	12TH FLOOR	14	ROOM	STUDIO	1	20.66	7.14	27.80	0	0
470	A	12TH FLOOR	14	ROOM	STUDIO	1	20.89	5.63	26.52	0	0
471	A	12TH FLOOR	14	ROOM	STUDIO	1	20.89	5.78	26.67	0	0
472	A	12TH FLOOR	14	ROOM	STUDIO	1	18.18	5.14	23.32	0	0
473	A	12TH FLOOR	14	ROOM	STUDIO	1	18.33	4.99	23.32	0	0
474	A	12TH FLOOR	14	ROOM	STUDIO	1	18.33	4.99	23.32	0	0
475	A	12TH FLOOR	14	ROOM	STUDIO	1	18.24	5.14	23.38	0	0
476	A	13TH FLOOR	15	ROOM	STUDIO	1	16.74	5.14	21.88	0	0
477	A	13TH FLOOR	15	ROOM	STUDIO	1	16.78	4.99	21.77	0	0
478	A	13TH FLOOR	15	ROOM	STUDIO	1	16.78	4.99	21.77	0	0
479	A	13TH FLOOR	15	ROOM	STUDIO	1	16.71	4.99	21.70	0	0
480	A	13TH FLOOR	15	ROOM	STUDIO	1	16.82	4.99	21.81	0	0
481	A	13TH FLOOR	15	ROOM	STUDIO	1	16.79	4.99	21.78	0	0
482	A	13TH FLOOR	15	ROOM	STUDIO	1	16.76	4.99	21.75	0	0
483	A	13TH FLOOR	15	ROOM	STUDIO	1	16.78	4.99	21.77	0	0
484	A	13TH FLOOR	15	ROOM	STUDIO	1	16.78	4.99	21.77	0	0
485	A	13TH FLOOR	15	ROOM	STUDIO	1	16.74	5.14	21.88	0	0
486	A	13TH FLOOR	15	ROOM	STUDIO	1	18.33	5.11	23.44	0	0
487	A	13TH FLOOR	15	ROOM	STUDIO	1	18.33	4.99	23.32	0	0
488	A	13TH FLOOR	15	ROOM	STUDIO	1	18.33	4.99	23.32	0	0
489	A	13TH FLOOR	15	ROOM	STUDIO	1	18.33	4.99	23.32	0	0
490	A	13TH FLOOR	15	ROOM	STUDIO	1	18.24	4.99	23.23	0	0
491	A	13TH FLOOR	15	ROOM	STUDIO	1	18.42	4.99	23.41	0	0
492	A	13TH FLOOR	15	ROOM	STUDIO	1	18.42	4.99	23.41	0	0
493	A	13TH FLOOR	15	ROOM	STUDIO	1	18.32	4.99	23.31	0	0
494	A	13TH FLOOR	15	ROOM	STUDIO	1	18.33	4.99	23.32	0	0
495	A	13TH FLOOR	15	ROOM	STUDIO	1	18.33	4.99	23.32	0	0

**KAVERI ELITE INFRA DEVELOPERS PVT. LTD.**

*(Signature)*  
Director

**INVENTORY SHEET ( CARPET AREA) OF KAVERI CITY CENTRE-2**

S.No.	Block No	Floor Number ( As per Maps)	Floor Number (As per RERA Portal)	Flat/ Apartment/ Shop/Plot type as Sanctioned Map	Flat/ Apartment/ Shop/Plot type as RERA Portal	Number of Apartment/F lats / Shop	Unit Carpet Area (in sqm)	Number of Balcony	Total Area of Unit + Balcony (in sqm)	Number of Verandah	Total Area of Garrage (in sqm)
496	A	13TH FLOOR	15	ROOM	STUDIO	1	18.24	5.14	23.38	0	0
497	A	13TH FLOOR	15	ROOM	STUDIO	1	16.74	5.14	21.88	0	0
498	A	13TH FLOOR	15	ROOM	STUDIO	1	16.78	4.99	21.77	0	0
499	A	13TH FLOOR	15	ROOM	STUDIO	1	16.78	4.99	21.77	0	0
500	A	13TH FLOOR	15	ROOM	STUDIO	1	16.64	5.14	21.78	0	0
501	A	13TH FLOOR	15	ROOM	STUDIO	1	16.64	5.14	21.78	0	0
502	A	13TH FLOOR	15	ROOM	STUDIO	1	16.78	4.99	21.77	0	0
503	A	13TH FLOOR	15	ROOM	STUDIO	1	16.78	4.99	21.77	0	0
504	A	13TH FLOOR	15	ROOM	STUDIO	1	16.78	4.99	21.77	0	0
505	A	13TH FLOOR	15	ROOM	STUDIO	1	16.78	4.99	21.77	0	0
506	A	13TH FLOOR	15	ROOM	STUDIO	1	16.82	4.99	21.81	0	0
507	A	13TH FLOOR	15	ROOM	STUDIO	1	16.78	4.99	21.77	0	0
508	A	13TH FLOOR	15	ROOM	STUDIO	1	16.78	5.14	21.92	0	0
509	A	13TH FLOOR	15	ROOM	STUDIO	1	26.03	7.14	33.17	0	0
510	A	13TH FLOOR	15	ROOM	STUDIO	1	20.89	5.63	26.52	0	0
511	A	13TH FLOOR	15	ROOM	STUDIO	1	20.89	5.78	26.67	0	0
512	A	13TH FLOOR	15	ROOM	STUDIO	1	18.18	5.14	23.32	0	0
513	A	13TH FLOOR	15	ROOM	STUDIO	1	18.33	4.99	23.32	0	0
514	A	13TH FLOOR	15	ROOM	STUDIO	1	18.33	4.99	23.32	0	0
515	A	13TH FLOOR	15	ROOM	STUDIO	1	18.24	5.14	23.38	0	0
516	A	14TH FLOOR	16	ROOM	STUDIO	1	16.74	5.14	21.88	0	0
517	A	14TH FLOOR	16	ROOM	STUDIO	1	16.78	4.99	21.77	0	0
518	A	14TH FLOOR	16	ROOM	STUDIO	1	16.78	4.99	21.77	0	0
519	A	14TH FLOOR	16	ROOM	STUDIO	1	16.71	4.99	21.70	0	0
520	A	14TH FLOOR	16	ROOM	STUDIO	1	16.82	4.99	21.81	0	0
521	A	14TH FLOOR	16	ROOM	STUDIO	1	16.79	4.99	21.78	0	0
522	A	14TH FLOOR	16	ROOM	STUDIO	1	16.76	4.99	21.75	0	0
523	A	14TH FLOOR	16	ROOM	STUDIO	1	16.78	4.99	21.77	0	0
524	A	14TH FLOOR	16	ROOM	STUDIO	1	16.78	4.99	21.77	0	0
525	A	14TH FLOOR	16	ROOM	STUDIO	1	16.74	5.14	21.88	0	0
526	A	14TH FLOOR	16	ROOM	STUDIO	1	18.33	5.11	23.44	0	0
527	A	14TH FLOOR	16	ROOM	STUDIO	1	18.33	4.99	23.32	0	0
528	A	14TH FLOOR	16	ROOM	STUDIO	1	18.33	4.99	23.32	0	0

**KAVERI ELITE INFRA  
DEVELOPERS PVT. LTD.**

*(Signature)*  
**Director**

INVENTORY SHEET ( CARPET AREA) OF KAVERI CITY CENTRE-2											
S.No.	Block No	Floor Number ( As per Maps)	Floor Number (As per RERA Portal)	Flat/ Apartment/ Shop/Plot type as Sanctioned Map	Flat/ Apartment/ Shop/Plot type as RERA Portal	Number of Apartment/F lats / Shop	Unit Carpet Area (in sqm)	Number of Balcony	Total Area of Unit + Balcony (in sqm)	Number of Verandah	Total Area of Garrage (in sqm)
529	A	14TH FLOOR	16	ROOM	STUDIO	1	18.33	4.99	23.32	0	0
530	A	14TH FLOOR	16	ROOM	STUDIO	1	18.24	4.99	23.23	0	0
531	A	14TH FLOOR	16	ROOM	STUDIO	1	18.42	4.99	23.41	0	0
532	A	14TH FLOOR	16	ROOM	STUDIO	1	18.42	4.99	23.41	0	0
533	A	14TH FLOOR	16	ROOM	STUDIO	1	18.32	4.99	23.31	0	0
534	A	14TH FLOOR	16	ROOM	STUDIO	1	18.33	4.99	23.32	0	0
535	A	14TH FLOOR	16	ROOM	STUDIO	1	18.33	4.99	23.32	0	0
536	A	14TH FLOOR	16	ROOM	STUDIO	1	18.24	5.14	23.38	0	0
537	A	14TH FLOOR	16	ROOM	STUDIO	1	16.74	5.14	21.88	0	0
538	A	14TH FLOOR	16	ROOM	STUDIO	1	16.78	4.99	21.77	0	0
539	A	14TH FLOOR	16	ROOM	STUDIO	1	16.78	4.99	21.77	0	0
540	A	14TH FLOOR	16	ROOM	STUDIO	1	16.64	5.14	21.78	0	0
541	A	14TH FLOOR	16	ROOM	STUDIO	1	16.64	5.14	21.78	0	0
542	A	14TH FLOOR	16	ROOM	STUDIO	1	16.78	4.99	21.77	0	0
543	A	14TH FLOOR	16	ROOM	STUDIO	1	16.78	4.99	21.77	0	0
544	A	14TH FLOOR	16	ROOM	STUDIO	1	16.78	4.99	21.77	0	0
545	A	14TH FLOOR	16	ROOM	STUDIO	1	16.78	4.99	21.77	0	0
546	A	14TH FLOOR	16	ROOM	STUDIO	1	16.82	4.99	21.81	0	0
547	A	14TH FLOOR	16	ROOM	STUDIO	1	16.78	4.99	21.77	0	0
548	A	14TH FLOOR	16	ROOM	STUDIO	1	16.78	5.14	21.92	0	0
549	A	14TH FLOOR	16	ROOM	STUDIO	1	26.03	7.14	33.17	0	0
550	A	14TH FLOOR	16	ROOM	STUDIO	1	20.89	5.63	26.52	0	0
551	A	14TH FLOOR	16	ROOM	STUDIO	1	20.89	5.78	26.67	0	0
552	A	14TH FLOOR	16	ROOM	STUDIO	1	18.18	5.14	23.32	0	0
553	A	14TH FLOOR	16	ROOM	STUDIO	1	18.33	4.99	23.32	0	0
554	A	14TH FLOOR	16	ROOM	STUDIO	1	18.33	4.99	23.32	0	0
555	A	14TH FLOOR	16	ROOM	STUDIO	1	18.24	5.14	23.38	0	0
556	A	Service Floor 3	17	Service Floor	Other	0	0	0	0	0	0
557	A	15TH FLOOR	18	ROOM	STUDIO	1	16.74	5.14	21.88	0	0
558	A	15TH FLOOR	18	ROOM	STUDIO	1	16.78	4.99	21.77	0	0
559	A	15TH FLOOR	18	ROOM	STUDIO	1	16.78	4.99	21.77	0	0
560	A	15TH FLOOR	18	ROOM	STUDIO	1	16.71	4.99	21.70	0	0
561	A	15TH FLOOR	18	ROOM	STUDIO	1	16.82	4.99	21.81	0	0

INVENTORY SHEET ( CARPET AREA) OF KAVERI CITY CENTRE-2											
S.No.	Block No	Floor Number ( As per Maps)	Floor Number (As per RERA Portal)	Flat/ Apartment/ Shop/Plot type as Sanctioned Map	Flat/ Apartment/ Shop/Plot type as RERA Portal	Number of Apartment/F lats / Shop	Unit Carpet Area (in sqm)	Number of Balcony	Total Area of Unit + Balcony (in sqm)	Number of Verandah	Total Area of Garrage (in sqm)
562	A	15TH FLOOR	18	ROOM	STUDIO	1	16.79	4.99	21.78	0	0
563	A	15TH FLOOR	18	ROOM	STUDIO	1	16.76	4.99	21.75	0	0
564	A	15TH FLOOR	18	ROOM	STUDIO	1	16.78	4.99	21.77	0	0
565	A	15TH FLOOR	18	ROOM	STUDIO	1	16.78	4.99	21.77	0	0
566	A	15TH FLOOR	18	ROOM	STUDIO	1	16.74	5.14	21.88	0	0
567	A	15TH FLOOR	18	ROOM	STUDIO	1	18.33	5.11	23.44	0	0
568	A	15TH FLOOR	18	ROOM	STUDIO	1	18.33	4.99	23.32	0	0
569	A	15TH FLOOR	18	ROOM	STUDIO	1	18.33	4.99	23.32	0	0
570	A	15TH FLOOR	18	ROOM	STUDIO	1	18.33	4.99	23.32	0	0
571	A	15TH FLOOR	18	ROOM	STUDIO	1	18.24	4.99	23.23	0	0
572	A	15TH FLOOR	18	ROOM	STUDIO	1	18.42	4.99	23.41	0	0
573	A	15TH FLOOR	18	ROOM	STUDIO	1	18.42	4.99	23.41	0	0
574	A	15TH FLOOR	18	ROOM	STUDIO	1	18.32	4.99	23.31	0	0
575	A	15TH FLOOR	18	ROOM	STUDIO	1	18.33	4.99	23.32	0	0
576	A	15TH FLOOR	18	ROOM	STUDIO	1	18.33	4.99	23.32	0	0
577	A	15TH FLOOR	18	ROOM	STUDIO	1	18.24	5.14	23.38	0	0
578	A	15TH FLOOR	18	ROOM	STUDIO	1	16.74	5.14	21.88	0	0
579	A	15TH FLOOR	18	ROOM	STUDIO	1	16.78	4.99	21.77	0	0
580	A	15TH FLOOR	18	ROOM	STUDIO	1	16.78	4.99	21.77	0	0
581	A	15TH FLOOR	18	ROOM	STUDIO	1	16.64	5.14	21.78	0	0
582	A	15TH FLOOR	18	ROOM	STUDIO	1	16.64	5.14	21.78	0	0
583	A	15TH FLOOR	18	ROOM	STUDIO	1	16.78	4.99	21.77	0	0
584	A	15TH FLOOR	18	ROOM	STUDIO	1	16.78	4.99	21.77	0	0
585	A	15TH FLOOR	18	ROOM	STUDIO	1	16.78	4.99	21.77	0	0
586	A	15TH FLOOR	18	ROOM	STUDIO	1	16.78	4.99	21.77	0	0
587	A	15TH FLOOR	18	ROOM	STUDIO	1	16.82	4.99	21.81	0	0
588	A	15TH FLOOR	18	ROOM	STUDIO	1	16.78	4.99	21.77	0	0
589	A	15TH FLOOR	18	ROOM	STUDIO	1	16.78	5.14	21.92	0	0
590	A	15TH FLOOR	18	ROOM	STUDIO	1	26.03	7.14	33.17	0	0
591	A	15TH FLOOR	18	ROOM	STUDIO	1	20.89	5.63	26.52	0	0
592	A	15TH FLOOR	18	ROOM	STUDIO	1	20.89	5.78	26.67	0	0
593	A	15TH FLOOR	18	ROOM	STUDIO	1	18.18	5.14	23.32	0	0
594	A	15TH FLOOR	18	ROOM	STUDIO	1	18.33	4.99	23.32	0	0

KAVERI ELITE INFRA  
DEVELOPERS PVT. LTD.

  
Director

INVENTORY SHEET ( CARPET AREA) OF KAVERI CITY CENTRE-2											
S.No.	Block No	Floor Number ( As per Maps)	Floor Number (As per RERA Portal)	Flat/ Apartment/ Shop/Plot type as Sanctioned Map	Flat/ Apartment/ Shop/Plot type as RERA Portal	Number of Apartment/F lats / Shop	Unit Carpet Area (in sqm)	Number of Balcony	Total Area of Unit + Balcony (in sqm)	Number of Verandah	Total Area of Garrage (in sqm)
595	A	15TH FLOOR	18	ROOM	STUDIO	1	18.33	4.99	23.32	0	0
596	A	15TH FLOOR	18	ROOM	STUDIO	1	18.24	5.14	23.38	0	0
597	A	16TH FLOOR	19	ROOM	STUDIO	1	16.74	5.14	21.88	0	0
598	A	16TH FLOOR	19	ROOM	STUDIO	1	16.78	4.99	21.77	0	0
599	A	16TH FLOOR	19	ROOM	STUDIO	1	16.78	4.99	21.77	0	0
600	A	16TH FLOOR	19	ROOM	STUDIO	1	16.71	4.99	21.70	0	0
601	A	16TH FLOOR	19	ROOM	STUDIO	1	16.82	4.99	21.81	0	0
602	A	16TH FLOOR	19	ROOM	STUDIO	1	16.79	4.99	21.78	0	0
603	A	16TH FLOOR	19	ROOM	STUDIO	1	16.76	4.99	21.75	0	0
604	A	16TH FLOOR	19	ROOM	STUDIO	1	16.78	4.99	21.77	0	0
605	A	16TH FLOOR	19	ROOM	STUDIO	1	16.78	4.99	21.77	0	0
606	A	16TH FLOOR	19	ROOM	STUDIO	1	16.74	5.14	21.88	0	0
607	A	16TH FLOOR	19	ROOM	STUDIO	1	18.33	5.11	23.44	0	0
608	A	16TH FLOOR	19	ROOM	STUDIO	1	18.33	4.99	23.32	0	0
609	A	16TH FLOOR	19	ROOM	STUDIO	1	18.33	4.99	23.32	0	0
610	A	16TH FLOOR	19	ROOM	STUDIO	1	18.33	4.99	23.32	0	0
611	A	16TH FLOOR	19	ROOM	STUDIO	1	18.24	4.99	23.23	0	0
612	A	16TH FLOOR	19	ROOM	STUDIO	1	18.42	4.99	23.41	0	0
613	A	16TH FLOOR	19	ROOM	STUDIO	1	18.42	4.99	23.41	0	0
614	A	16TH FLOOR	19	ROOM	STUDIO	1	18.32	4.99	23.31	0	0
615	A	16TH FLOOR	19	ROOM	STUDIO	1	18.33	4.99	23.32	0	0
616	A	16TH FLOOR	19	ROOM	STUDIO	1	18.33	4.99	23.32	0	0
617	A	16TH FLOOR	19	ROOM	STUDIO	1	18.24	5.14	23.38	0	0
618	A	16TH FLOOR	19	ROOM	STUDIO	1	16.74	5.14	21.88	0	0
619	A	16TH FLOOR	19	ROOM	STUDIO	1	16.78	4.99	21.77	0	0
620	A	16TH FLOOR	19	ROOM	STUDIO	1	16.78	4.99	21.77	0	0
621	A	16TH FLOOR	19	ROOM	STUDIO	1	16.64	5.14	21.78	0	0
622	A	16TH FLOOR	19	ROOM	STUDIO	1	16.64	5.14	21.78	0	0
623	A	16TH FLOOR	19	ROOM	STUDIO	1	16.78	4.99	21.77	0	0
624	A	16TH FLOOR	19	ROOM	STUDIO	1	16.78	4.99	21.77	0	0
625	A	16TH FLOOR	19	ROOM	STUDIO	1	16.78	4.99	21.77	0	0
626	A	16TH FLOOR	19	ROOM	STUDIO	1	16.78	4.99	21.77	0	0
627	A	16TH FLOOR	19	ROOM	STUDIO	1	16.82	4.99	21.81	0	0

KAVERI ELITE INFRA  
DEVELOPERS PVT. LTD.

  
Director

INVENTORY SHEET ( CARPET AREA) OF KAVERI CITY CENTRE-2											
S.No.	Block No	Floor Number ( As per Maps)	Floor Number (As per RERA Portal)	Flat/ Apartment/ Shop/Plot type as Sanctioned Map	Flat/ Apartment/ Shop/Plot type as RERA Portal	Number of Apartment/F lats / Shop	Unit Carpet Area (in sqm)	Number of Balcony	Total Area of Unit + Balcony (in sqm)	Number of Verandah	Total Area of Garrage (in sqm)
628	A	16TH FLOOR	19	ROOM	STUDIO	1	16.78	4.99	21.77	0	0
629	A	16TH FLOOR	19	ROOM	STUDIO	1	16.78	5.14	21.92	0	0
630	A	16TH FLOOR	19	ROOM	STUDIO	1	20.66	7.14	27.80	0	0
631	A	16TH FLOOR	19	ROOM	STUDIO	1	20.89	5.63	26.52	0	0
632	A	16TH FLOOR	19	ROOM	STUDIO	1	20.89	5.78	26.67	0	0
633	A	16TH FLOOR	19	ROOM	STUDIO	1	18.18	5.14	23.32	0	0
634	A	16TH FLOOR	19	ROOM	STUDIO	1	18.33	4.99	23.32	0	0
635	A	16TH FLOOR	19	ROOM	STUDIO	1	18.33	4.99	23.32	0	0
636	A	16TH FLOOR	19	ROOM	STUDIO	1	18.24	5.14	23.38	0	0
637	A	17TH FLOOR	20	ROOM	STUDIO	1	16.74	5.14	21.88	0	0
638	A	17TH FLOOR	20	ROOM	STUDIO	1	16.78	4.99	21.77	0	0
639	A	17TH FLOOR	20	ROOM	STUDIO	1	16.78	4.99	21.77	0	0
640	A	17TH FLOOR	20	ROOM	STUDIO	1	16.71	4.99	21.70	0	0
641	A	17TH FLOOR	20	ROOM	STUDIO	1	16.82	4.99	21.81	0	0
642	A	17TH FLOOR	20	ROOM	STUDIO	1	16.79	4.99	21.78	0	0
643	A	17TH FLOOR	20	ROOM	STUDIO	1	16.76	4.99	21.75	0	0
644	A	17TH FLOOR	20	ROOM	STUDIO	1	16.78	4.99	21.77	0	0
645	A	17TH FLOOR	20	ROOM	STUDIO	1	16.78	4.99	21.77	0	0
646	A	17TH FLOOR	20	ROOM	STUDIO	1	16.74	5.14	21.88	0	0
647	A	17TH FLOOR	20	ROOM	STUDIO	1	18.33	5.11	23.44	0	0
648	A	17TH FLOOR	20	ROOM	STUDIO	1	18.33	4.99	23.32	0	0
649	A	17TH FLOOR	20	ROOM	STUDIO	1	18.33	4.99	23.32	0	0
650	A	17TH FLOOR	20	ROOM	STUDIO	1	18.33	4.99	23.32	0	0
651	A	17TH FLOOR	20	ROOM	STUDIO	1	18.24	4.99	23.23	0	0
652	A	17TH FLOOR	20	ROOM	STUDIO	1	18.42	4.99	23.41	0	0
653	A	17TH FLOOR	20	ROOM	STUDIO	1	18.42	4.99	23.41	0	0
654	A	17TH FLOOR	20	ROOM	STUDIO	1	18.32	4.99	23.31	0	0
655	A	17TH FLOOR	20	ROOM	STUDIO	1	18.33	4.99	23.32	0	0
656	A	17TH FLOOR	20	ROOM	STUDIO	1	18.33	4.99	23.32	0	0
657	A	17TH FLOOR	20	ROOM	STUDIO	1	18.24	5.14	23.38	0	0
658	A	17TH FLOOR	20	ROOM	STUDIO	1	16.74	5.14	21.88	0	0
659	A	17TH FLOOR	20	ROOM	STUDIO	1	16.78	4.99	21.77	0	0
660	A	17TH FLOOR	20	ROOM	STUDIO	1	16.78	4.99	21.77	0	0

KAVERI ELITE INFRA  
DEVELOPERS PVT. LTD.

  
Director

INVENTORY SHEET ( CARPET AREA) OF KAVERI CITY CENTRE-2											
S.No.	Block No	Floor Number ( As per Maps)	Floor Number (As per RERA Portal)	Flat/ Apartment/ Shop/Plot type as Sanctioned Map	Flat/ Apartment/ Shop/Plot type as RERA Portal	Number of Apartment/F lats / Shop	Unit Carpet Area (in sqm)	Number of Balcony	Total Area of Unit + Balcony (in sqm)	Number of Verandah	Total Area of Garrage (in sqm)
661	A	17TH FLOOR	20	ROOM	STUDIO	1	16.64	5.14	21.78	0	0
662	A	17TH FLOOR	20	ROOM	STUDIO	1	16.64	5.14	21.78	0	0
663	A	17TH FLOOR	20	ROOM	STUDIO	1	16.78	4.99	21.77	0	0
664	A	17TH FLOOR	20	ROOM	STUDIO	1	16.78	4.99	21.77	0	0
665	A	17TH FLOOR	20	ROOM	STUDIO	1	16.78	4.99	21.77	0	0
666	A	17TH FLOOR	20	ROOM	STUDIO	1	16.78	4.99	21.77	0	0
667	A	17TH FLOOR	20	ROOM	STUDIO	1	16.82	4.99	21.81	0	0
668	A	17TH FLOOR	20	ROOM	STUDIO	1	16.78	4.99	21.77	0	0
669	A	17TH FLOOR	20	ROOM	STUDIO	1	16.78	5.14	21.92	0	0
670	A	17TH FLOOR	20	ROOM	STUDIO	1	26.03	7.14	33.17	0	0
671	A	17TH FLOOR	20	ROOM	STUDIO	1	20.89	5.63	26.52	0	0
672	A	17TH FLOOR	20	ROOM	STUDIO	1	20.89	5.78	26.67	0	0
673	A	17TH FLOOR	20	ROOM	STUDIO	1	18.18	5.14	23.32	0	0
674	A	17TH FLOOR	20	ROOM	STUDIO	1	18.33	4.99	23.32	0	0
675	A	17TH FLOOR	20	ROOM	STUDIO	1	18.33	4.99	23.32	0	0
676	A	17TH FLOOR	20	ROOM	STUDIO	1	18.24	5.14	23.38	0	0
677	A	18TH FLOOR	21	ROOM	STUDIO	1	16.74	5.14	21.88	0	0
678	A	18TH FLOOR	21	ROOM	STUDIO	1	16.78	4.99	21.77	0	0
679	A	18TH FLOOR	21	ROOM	STUDIO	1	16.78	4.99	21.77	0	0
680	A	18TH FLOOR	21	ROOM	STUDIO	1	16.71	4.99	21.70	0	0
681	A	18TH FLOOR	21	ROOM	STUDIO	1	16.82	4.99	21.81	0	0
682	A	18TH FLOOR	21	ROOM	STUDIO	1	16.79	4.99	21.78	0	0
683	A	18TH FLOOR	21	ROOM	STUDIO	1	16.76	4.99	21.75	0	0
684	A	18TH FLOOR	21	ROOM	STUDIO	1	16.78	4.99	21.77	0	0
685	A	18TH FLOOR	21	ROOM	STUDIO	1	16.78	4.99	21.77	0	0
686	A	18TH FLOOR	21	ROOM	STUDIO	1	16.74	5.14	21.88	0	0
687	A	18TH FLOOR	21	ROOM	STUDIO	1	16.82	4.99	21.81	0	0
688	A	18TH FLOOR	21	ROOM	STUDIO	1	16.78	4.99	21.77	0	0
689	A	18TH FLOOR	21	ROOM	STUDIO	1	16.78	4.99	21.77	0	0
690	A	18TH FLOOR	21	ROOM	STUDIO	1	16.82	4.99	21.81	0	0
691	A	18TH FLOOR	21	ROOM	STUDIO	1	16.78	4.99	21.77	0	0
692	A	18TH FLOOR	21	ROOM	STUDIO	1	16.78	5.14	21.92	0	0
693	A	18TH FLOOR	21	ROOM	STUDIO	1	26.03	7.14	33.17	0	0

KAVERI ELITE INFRA  
DEVELOPERS PVT. LTD.

  
Director

INVENTORY SHEET ( CARPET AREA) OF KAVERI CITY CENTRE-2											
S.No.	Block No	Floor Number ( As per Maps)	Floor Number (As per RERA Portal)	Flat/ Apartment/ Shop/Plot type as Sanctioned Map	Flat/ Apartment/ Shop/Plot type as RERA Portal	Number of Apartment/F lats / Shop	Unit Carpet Area (in sqm)	Number of Balcony	Total Area of Unit + Balcony (in sqm)	Number of Verandah	Total Area of Garrage (in sqm)
694	A	18TH FLOOR	21	ROOM	STUDIO	1	20.89	5.63	26.52	0	0
695	A	18TH FLOOR	21	ROOM	STUDIO	1	20.89	5.78	26.67	0	0
696	A	18TH FLOOR	21	ROOM	STUDIO	1	18.18	5.14	23.32	0	0
697	A	18TH FLOOR	21	ROOM	STUDIO	1	18.33	4.99	23.32	0	0
698	A	18TH FLOOR	21	ROOM	STUDIO	1	18.33	4.99	23.32	0	0
699	A	18TH FLOOR	21	ROOM	STUDIO	1	18.24	5.14	23.38	0	0
700	A	18TH FLOOR	21	ROOM	STUDIO	1	16.82	4.99	21.81	0	0
701	A	18TH FLOOR	21	ROOM	STUDIO	1	16.78	4.99	21.77	0	0
					<b>Total</b>	<b>693</b>					

**KAVERI ELITE INFRA  
DEVELOPERS PVT. LTD.**

  
**Director**