

नगर अप

Greater Noida Industrial Development Authority

PLOT NO-01, Sector-K.P.-04, Greater Noida, Gautam Budh Nagar, 201306

Plot No. CS-29/SC-36/5350

Dated... 21/8/17

M/S SHUBHSIDDHI INFRATECH (P) LTD.
CS-29, SECTOR-36
GREATER NOIDA

Sir,

With reference to your application no. dated 19.07.2017 for grant of SANCTION of CONVENIENT SHOPPING building plan on Plot no-CS-29, sector-36, Greater Noida I have to inform you that the sanction is being granted by the Authority with the following conditions:

1. This sanction is being granted under the provision of 'The Greater Noida Industrial Development Area Building Regulation 2005.
2. The validity of this sanction is upto-5 YEARS
3. In case allotment is cancelled/lease is determined for whatsoever reason by functional department, aforesaid sanction shall automatically be deemed to have been withdrawn.
4. During this period, after the completion of construction it is necessary to apply for occupancy certificate. Time extension charges shall be payable as applicable.
5. If demanded by the Authority, You shall be liable to pay charges for the provision of any further facilities/development/improvement.
6. A copy of the sanction drawing shall always be kept at site and shall be made available to any officer of the Authority on demand.
7. No addition/alteration is permitted in the sanctioned drawings. For any changes prior permission from the Authority required.
8. You shall be responsible for carrying out the work in accordance with the requirements of Greater Noida Industrial Development Building Regulation 2010, and direction made from time to time.
9. Prior permission is required before digging an under ground bore well.
10. No activity other than as specified in lease deed shall be permitted in the premises
11. Prior permission from the Authority is required for temporary structure also like labour huts & site office
12. Gate shall open on to the service road only. Direct access to the main carriageway shall not be provided.
13. Services, rain water harvesting shall be laid as per approval of Authority.
14. No parking of any kind shall be permitted on r/w of road.
15. Pegometer shall have to be installed as per direction issued by Authority.
16. Complying with all the requirement for obtaining NOC from various departments prior to submission of application for occupancy shall be the responsibility of allottee irrespective of the proposal sanctioned by GNIDA.
17. In case of any change in the parameters which require clearance for ministry of environment, govt. of India, the applicant shall be responsible to obtain the same before starting construction.
18. Mechanical ventilation to be provided in the basement as per I.S. code.
19. The promoter shall follow the apartment Act-2010 and its applicability to the project as per defined rules and amendments made in future. As per the provision of u.p. apartment rules 2011.

Nishit Ch
DGM (Plng & Arch.)

Encl. Copy of sanctioned drawings ()
Copy to G.M. (Engg.) for information and n.a.



GREATER NOIDA INDUSTRIAL DEVELOPMENT AUTHORITY

H-169, Chitvan Estate, SECTOR GAMMA GREATER NOIDA CITY,
GREATER NOIDA, DISTRICT GAUTAM BUDDH NAGAR-201308, (U.P.)
Fax 0120-2326334/2326145 PH 95:20-2326335/6/7/2326150/1/2/3/4/5
e-Mail: authority@gnida.in, WebSite: www.greaternoidaauthority.in

Allotment Cum Intimation Letter

Ref. Commercial/ CBP--VII /Allot/ 2016 / 3530
Allotment Date 04-Nov-2016

Scheme Code : CBP--VII
Form Serial No : I-CS-4000745
Size of Plot : 2,000.00 Sq. m.
Payment Plan : UNEQUAL HALF YEARLY

To,

M/S SHAGUN ASSOCIATES PRIVATE LIMITED (CONSORTIUM)

103, SHARMA COMPLEX, A-2, GURU NANAK PURA
LAXMI NAGAR,
DELHI

Dear Sir/Madam,

May kindly refer to your Application Form No. I-CS-4000745 of Commercial Scheme CBP--VII for allotment of Commercial PLOT in Greater Noida Area.

The Authority is pleased to allot the Commercial PLOT No. CS-29 of Sector SECTOR 36 Block NILL measuring 2,000.00 Sqm on lease for a period of 90 years:-

1. a) Your Allotment Number is- : CBP--VII00001
b) Total Allotted Area : 2,000.00 Sqm.
c) Rate of Allotment : Rs. 46,300.00
d) Premium Amt : Rs. 92,600,000.00
e) Allotment Money (20% of Premium) : Rs. 18,520,000.00
f) Registration/Earnest Money deposited : Rs. 10,000,000.00
g) Allotment Money payable by 4-Mar-2017 (after adjustment of registration/earnest money) : Rs. 8,520,000.00
2. Balance 80% amount with interest @ 12% per annum will be payable in 16 half yearly installments
Details of payment-schedule of installments are enclosed as Annexure-I
3. The Payable amount shall be deposited in any of the following bank branches directly through a Bank Draft/Pay order drawn in favour of GREATER NOIDA INDUSTRIAL DEVELOPMENT AUTHORITY payable at GREATER NOIDA/NOIDA/NEW DELHI.

S.No.	BANK NAME	Branch Address
1	BANK OF BARODA	GAMMA-II GREATER NOIDA

(Please write your NAME, ALLOTMENT NUMBER, SHOP/KIOSK/PLOT NO, SCHEME CODE and SECTOR NAME on the covering letter and also on the back of the Draft/Pay Order)

4. The Terms & Condition of the broucher of the scheme CBP--VII shall form part of this Allotment Letter and shall be binding on the allottees. This allotment letter is subject to realization of earnest money draft submitted alongwith tender application form and confirmation of certificate for eligibility if any, as per terms of broucher

Yours Sincerely

Manager(Commeretal)



GREATER NOIDA INDUSTRIAL DEVELOPMENT AUTHORITY

POSSESSION CERTIFICATE

Letter No. GN/comm/214
Date 2/6/2017

Plot Code
Allotment No. CBP-VII00001
Plot No. CS-29
Block No. -
Sector 36

Lessee / Allottee's Name
& Address M.L. Shubhsiddhi
Infratech Pvt. Ltd. Through
Director: Ayush Goyal P/o 206,
SF, Krishna Apara Plaza, Sector Alpha
Greater Noida

Status/Boundaries of plot	Dimensions	Area (In Sq. m.)	Remarks
North-East.....		1985-00 Sq. m	
South-West.....			
South-East.....			
North-West.....			

Site plan of the plot is enclosed herewith.
I/We have taken over possession of the plot No. CS-29 Block No. - Sector 36 on.....

I/We agree with the plot size, area, earmarked in the enclosed plan and the plot is free from encroachment.

Possession handed over by

[Signature]

Possession taken over by

For Shubhsiddhi Infratech (P) Ltd.

[Signature]

Director

H-169, SECTOR-GAMMA, GREATER NOIDA CITY
DISTT. GAUTAM BUDH NAGAR (U.P.)
PIN - 201 308

Signature of the lessee

Copy to

1. Lessee
2. General Manager (Property)
3. General Manager (Engg.)
4. General Manager (Finance)

H-169, SECTOR-GAMMA, GREATER NOIDA CITY
DISTT. GAUTAM BUDH NAGAR (U.P.)
PIN - 201 308

276

PLOT NO. - CS-29

PLOT NO. - 8,9,10,11,12,13

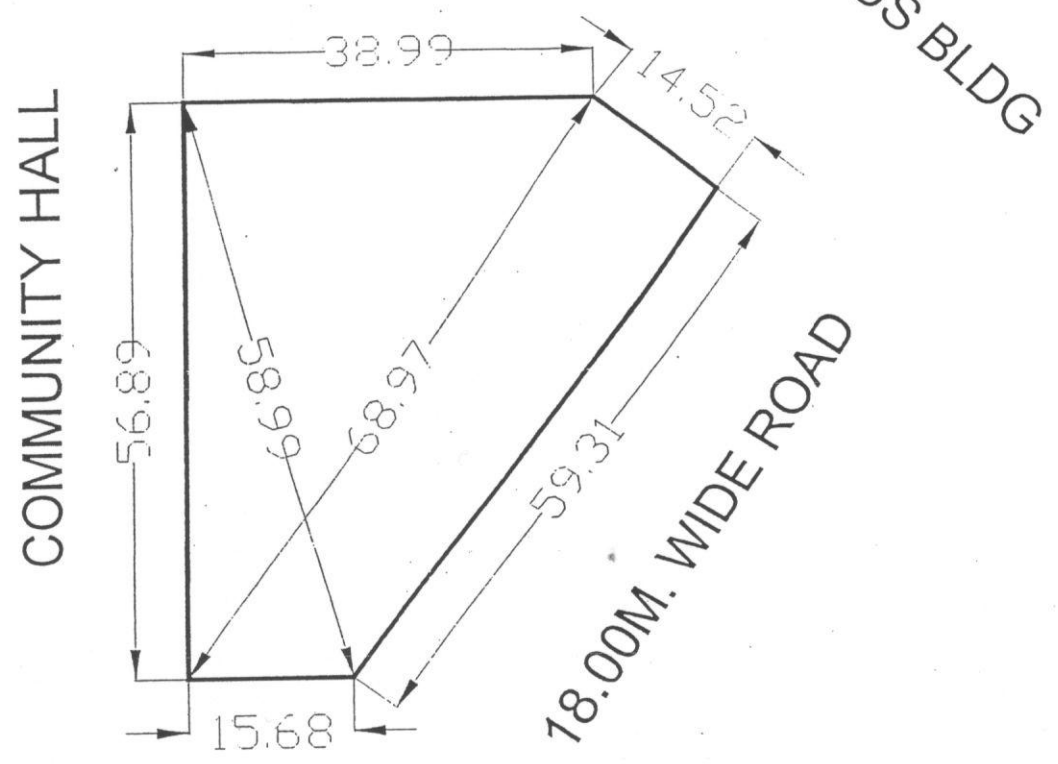

18.00M. WIDE ROAD

AREA = 1985.00 SQM

SIGN

[Signature]

SIGN

For Shubhsiddhi Infratech (P) Ltd.

[Signature]

POSSESSION TAKEN OVER

POSSESSION HANDED OVER

Director



LEASE PLAN FOR PLOT NO. :- CS-29

SECTOR -36

GREATER NOIDA

DRAFTSMAN

[Signature]
4-1-2017
ASST. MGR (ENGG)

MGR (ENGG)

[Signature]
04/01/17

SR. MGR (ENGG)



GREATER NOIDA INDUSTRIAL DEVELOPMENT AUTHORITY

PRODUCED BY AN AUTODESK EDUCATIONAL PRODUCT