

PLOT NO: 413 (GOVERNMENT OFFICE)

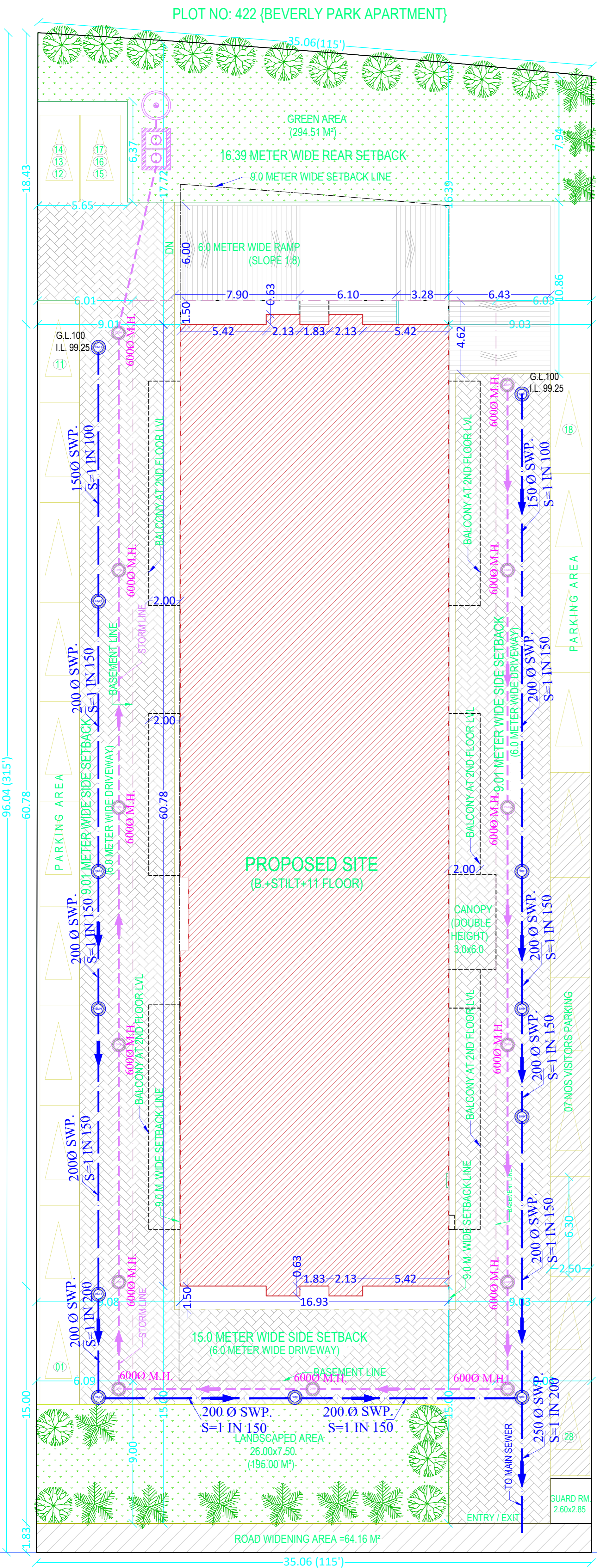

18.0 METER WIDE PROPOSED ROAD
(14.63 METER (48'-0") WIDE EXISTING ROAD)

WASTE DISPOSAL PLAN

PLOT NO: 415 (ELDECO EMPEREUR APARTMENTS)

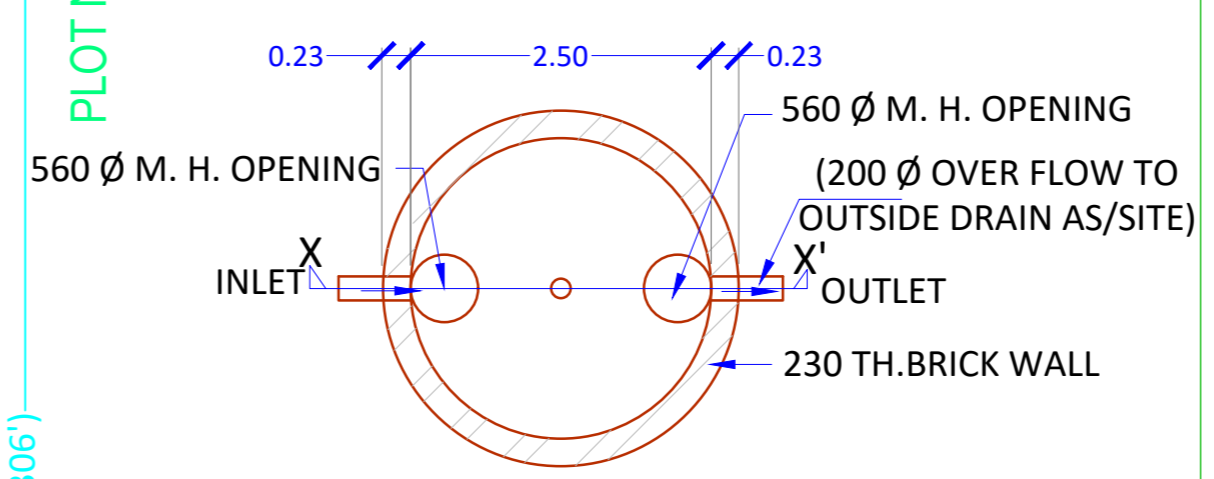

PLAN OF RECHARGE PIT

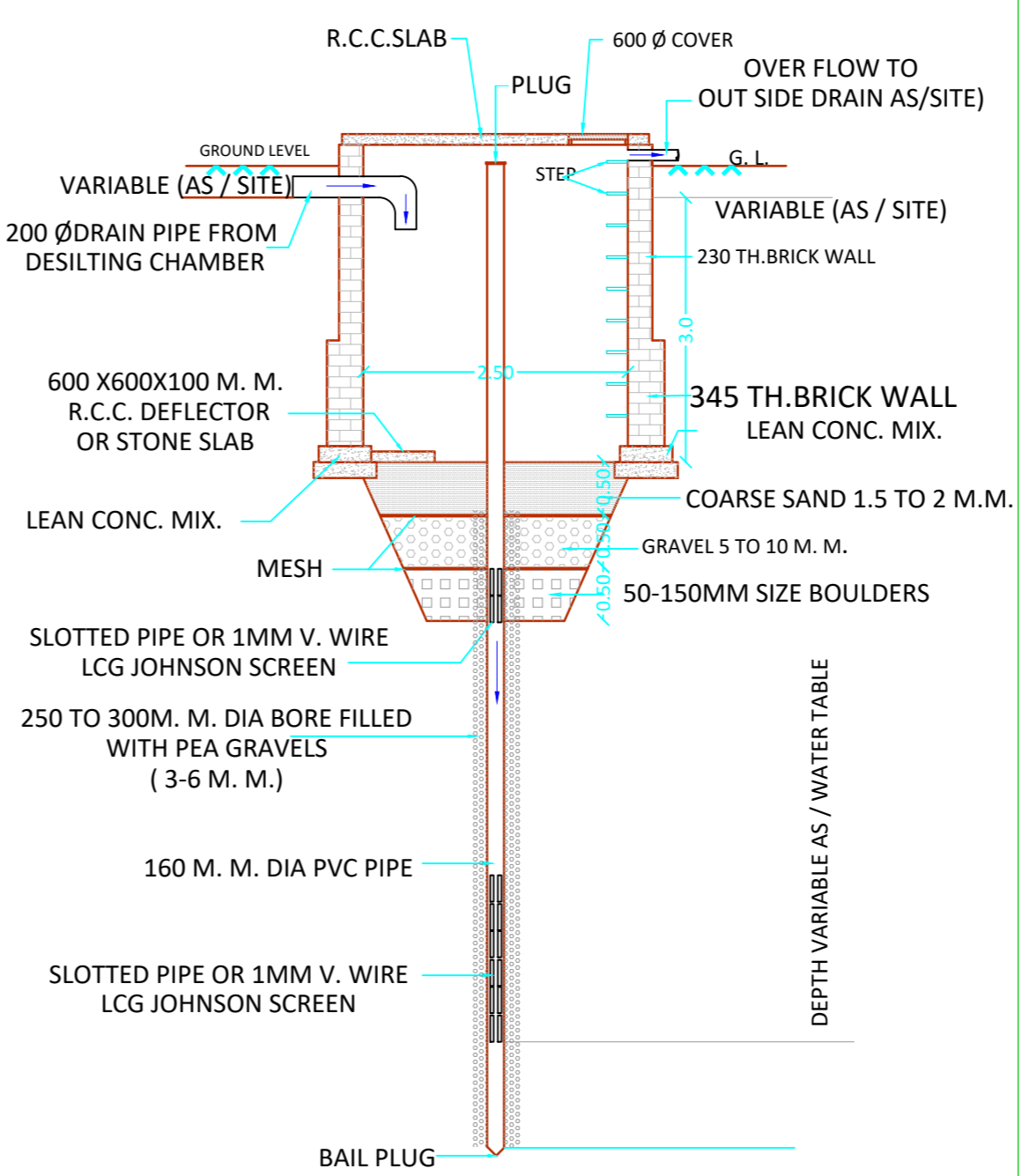

**SECTION XX'
RECHARGE PIT**

LEGEND FOR SERVICES	
	SEWER LINE
	800 Ø SEWER MAN HOLE
	RAIN WATER TANK IN LAWN
	200 Ø RAIN WATER LINE
	RAIN WATER HARVESTING SYSTEM

PROJECT
PROPOSED GROUP HOUSING
FOR
SIKKA RIVERSIDE RESIDENCY PRIVATE LIMITED
AT
PLOT NUMBER 414 T.G. NEW CIVIL LINE SCHEME, NEW HYDERABAD, HYDERABAD ROAD BEARING MUNICIPAL NUMBER 509/365(169), PURANA HYDERABAD (1968), LUCKNOW

NOTES:- SEWERAGE

- ALL DIMENSIONS ARE IN METER UNLESS NOTED OTHERWISE.
- FOR PIPES SIZE, SLOPES, LEVELS ETC. REFER DRAWINGS.
- ANY DISCREPANCY IN THE DRAWING SHALL BE BROUGHT TO THE NOTICE OF THE ARCHITECT/S./ CONSULTANTS.
- ALL PIPES USED ARE OF NON PRESSURE NP2 CLASS R.C.C PIPES WITH COLLARS JOINED WITH STIFF MIXTURE OF CEMENT MORTAR IN PROPORTION OF 1:2 (1 CEMENT : 2 FINE SAND)
- SEWER LINE LAYOUT IS INDICATIVE SEWER SHALL BE LAID ALIGNED AS PER ACTUAL ROAD SECTION AND LEVEL.
- THIS DRAWING SHOULD BE READ IN CONJUNCTION AND OTHER RELEVANT ARCHITECTURAL, STRUCTURAL AND OTHER SERVICES DRAWINGS.
- SEWER LINE SHALL BE CONSTRUCTED AS PER DETAIL.
- MAN HOLE SIZE SHALL BE AS FOLLOWS :-
(i) 800 Ø UP TO 1.00 M. DEPTH
(ii) 1000 Ø UP TO 2.00 M. DEPTH
- PIPE SHALL BE LAID OF FOLLOWING SLOPES:-
(a) 150 Ø NP2. - 1 IN 100
(b) 200 Ø NP2. - 1 IN 150
(c) 250 Ø NP2. - 1 IN 200

NOTES:- RAIN WATER HARVESTING

- THE SIZE OF CHAMBER SHALL BE 600 MM. Ø FOR CARRYING RAIN WATER DISCHARGE.
- THE PIPE SHALL BE 150 Ø NP2 SLOPE 1 IN 150 UNLESS MENTIONED
- ALL RAIN WATER PITS (IN THE PARKS) SHALL HAVE OVER FLOW PIPE 250 MM. DIA. WHICH SHALL BE CONNECTED TO THE SURFACE DRAIN. (250 Ø NP2. PIPE SLOPE = 1 IN 200)

REMARK

- Dimensions are to be read not to be measured.
- Any discrepancy in the drawing, if any, should be brought to the notice of the architect immediately.
- All dimensions are in meter.
- All dimension & levels are from unfinished architectural surface.
- All the rights of the drawing are reserved with the architect. Reproducing the drawings in any form without the prior permission of architect is not permitted.
- If no remarks / suggestions are given within fifteen days from the release date of the drawing the drawing shall be deemed as final draft.
- All the information regarding the land / building & its surrounding is provided by the owner.
- Architect shall not be responsible for any kind of discrepancy regarding land information.

SCALE	DATE	DRG. NO.-
1 : 100	AUGUST - 2025	1/6

DRG. TITLE
WASTE DISPOSAL PLAN

DRAWN BY	NORTH
AJAI KISHORE	

OWNER SIGNATURE	ARCHITECT SIGNATURE

ARCHITECT

PUNIT SRIVASTAV VASTULIPI
ARCHITECTS, DESIGNERS & PLANNERS
vastulipi@gmail.com, 09935590999
www.vastulipi.com