

SITE PLAN- PL-DRAINAGE LAYOUT

PROJECT NAME :- SHALIMAR GALLANT METROPOLIS

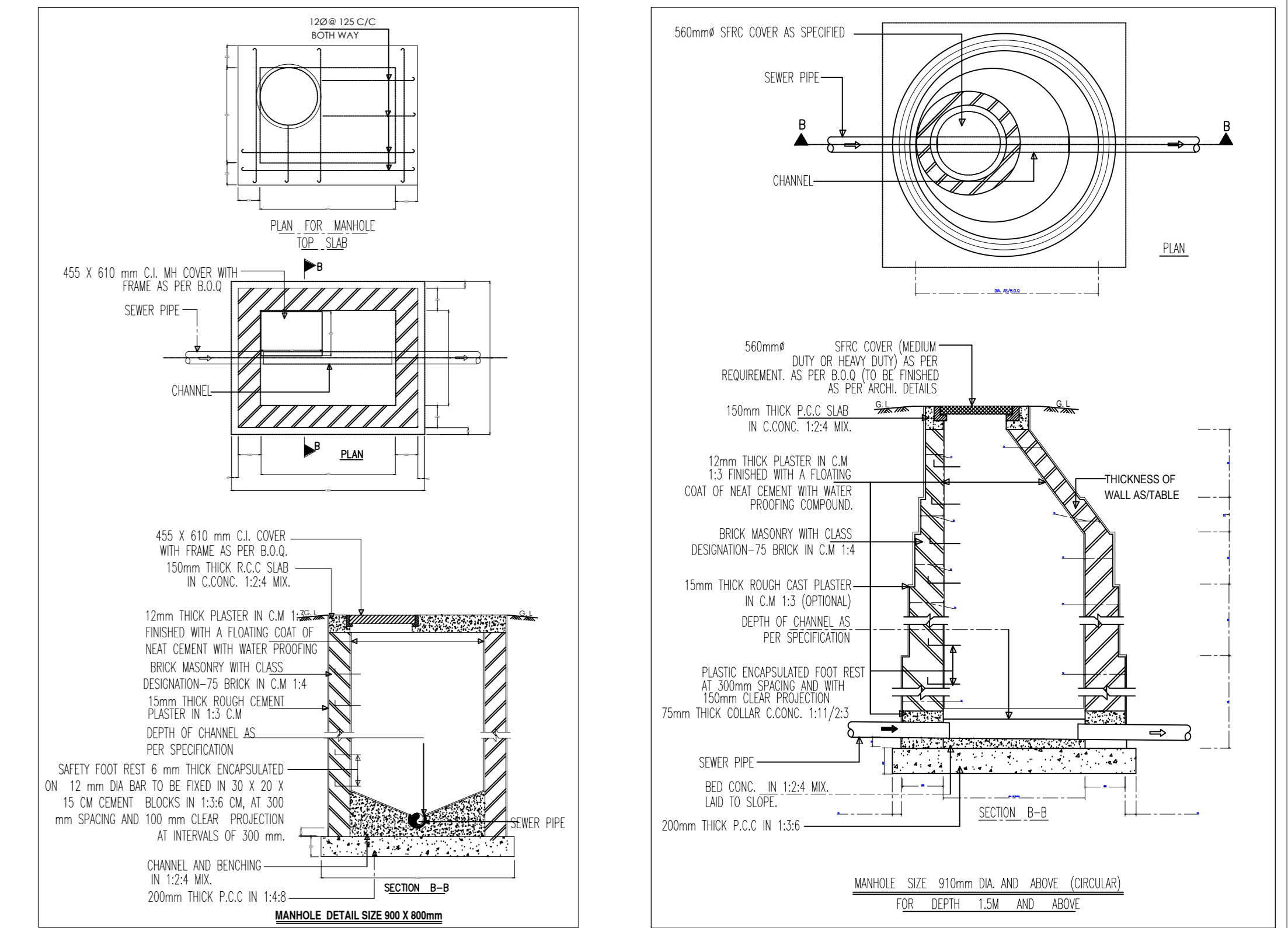
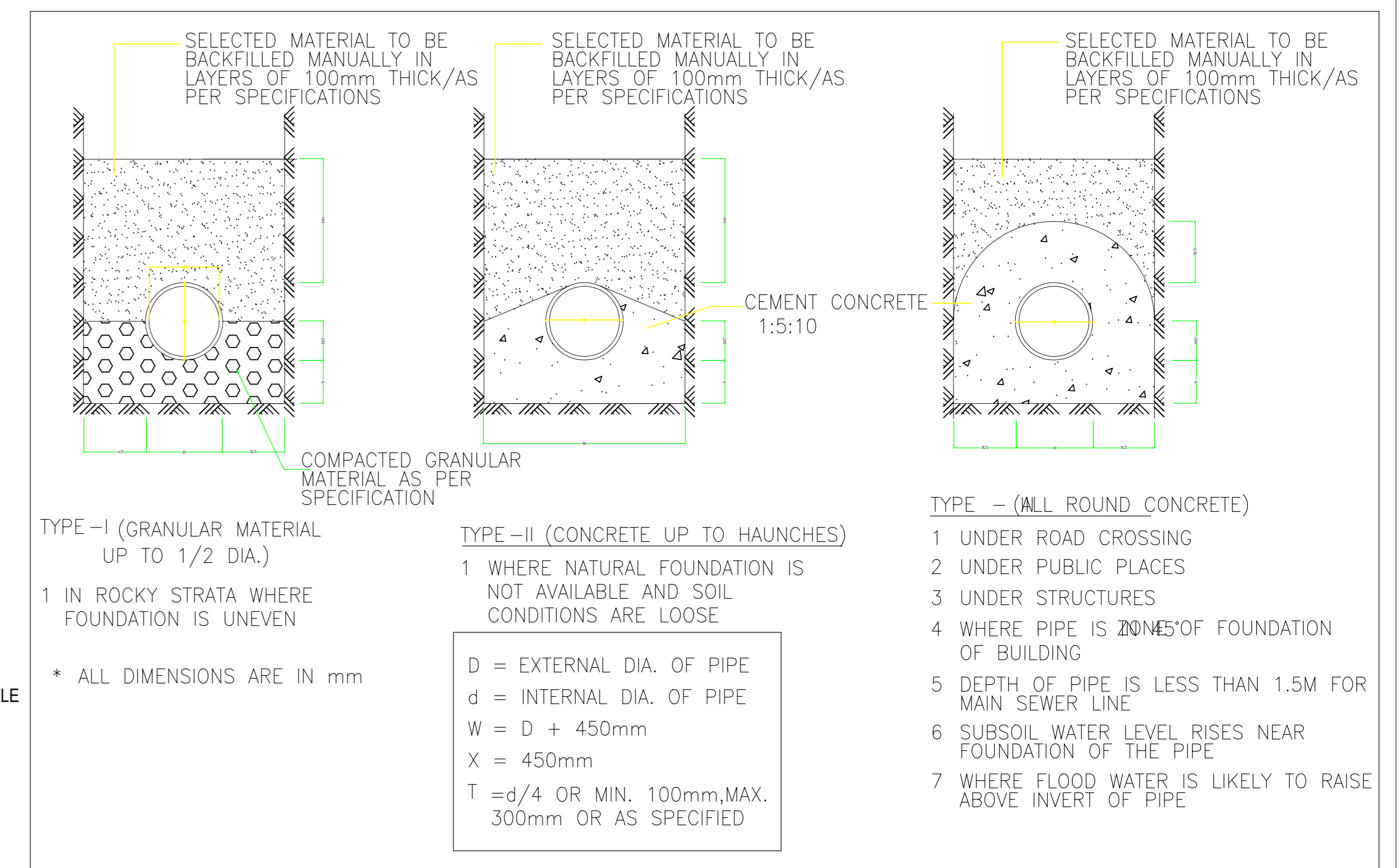
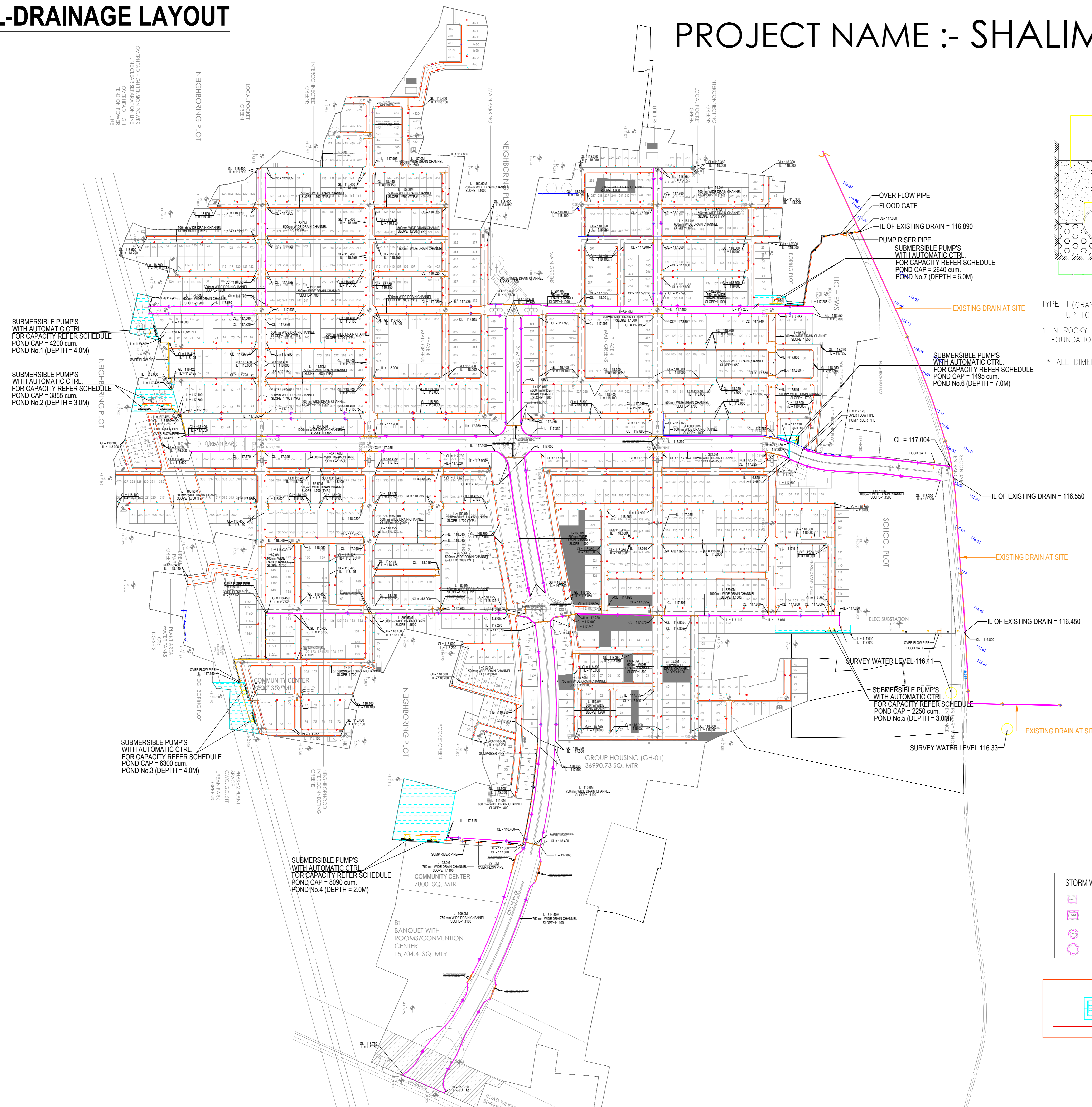

STORM WATER DRAINAGE LEGEND :-	DEPTH
	Less Than 0.90m
	From 0.90m And Up To 2.5m
	Above 0.90m And Up To 1.65m
	Above 1.65m And Up To 2.3m

①.....
②..... SCHEDULE OF MATERIAL:-
STORM WATER LINE:- HDPE DWC SN-4 PIPES
SEWERAGE LINE:- HDPE DWC SN-4 PIPES

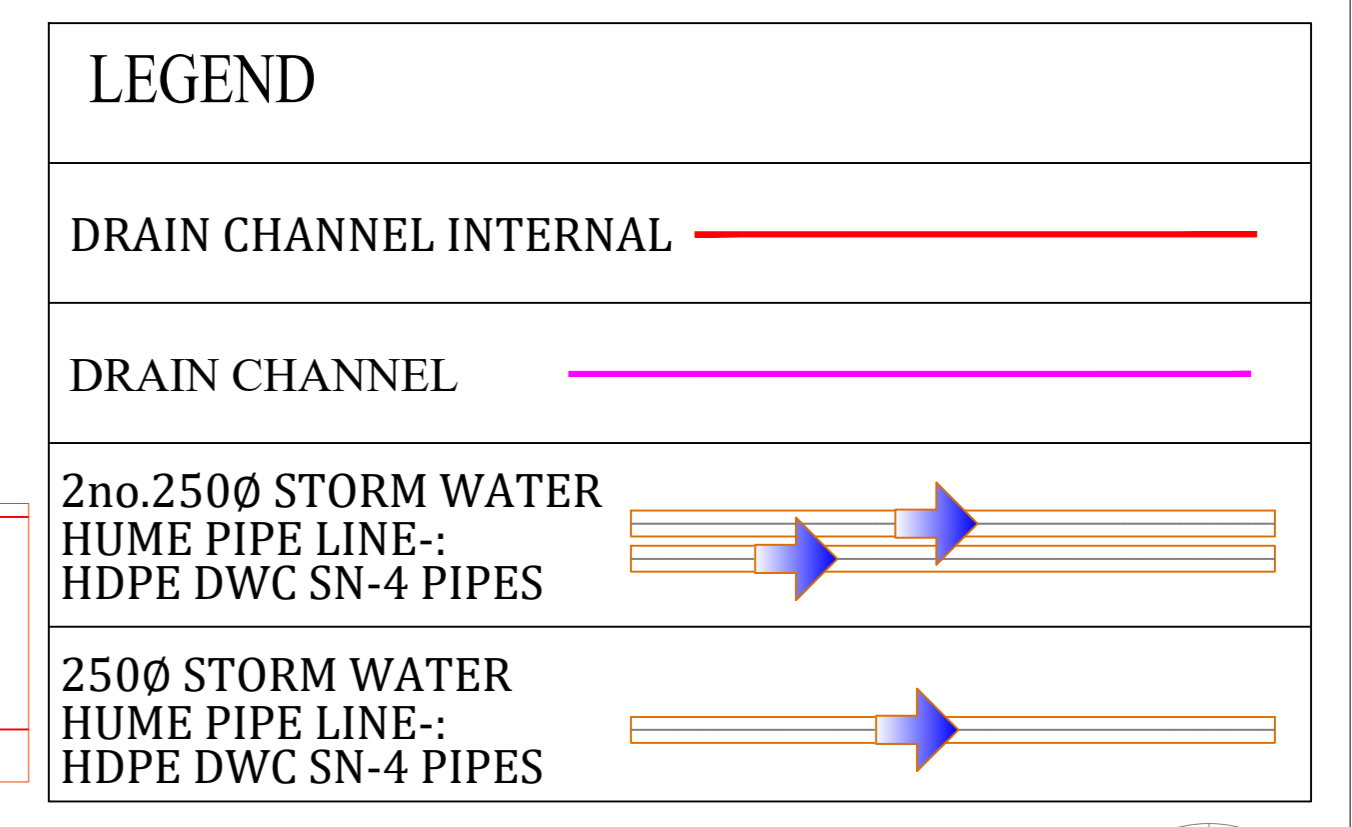

PROJECT TITLE -
PROPOSED LAYOUT PLAN OF AN NEW TOWNSHIP VILLAGE KAJOORGAON & TINDOLA, LUCKNOW - DEVA ROAD, TEHSHIL NAWABGANJ, DISTRICT - BARABANKI, U.P.

DATE - 20.06.2025
SCALE - 1 : 1000
NOTE :-
Compensatory F.A.R. against master plan road and EWS-LIG shall be utilized in the project during the approval of building plans

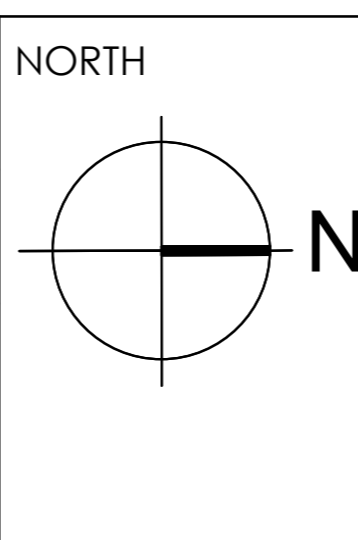

Architect Name
RAGHAVA ARCHITECTS
Head office Indrapuram :
Plot No. Cs-09, 2nd floor, Commercial Market, Gyan Khand-II, Near St. Thomas School, Indrapuram Ghaziabad-201014 (U.P.)
Branch office
Office No - 717, TCG - 8/8 and 9/9, Vibhuti Khand, Gomti Nagar Lucknow-226010, Uttar Pradesh (India)
Indrapuram, Wave City, Lucknow Meerut
+91 9810379715, 9891146128
www.raghavaarchitects.com | raghavaarchitects@gmail.com

OWNER/Developers:-
M/S. SHALIMAR CORP LIMITED
OWNER/Developers Adress:-
11th Floor, Shalimar Titanium, Shalimar Corporate park , Vibhuti Khand, Gomti Nagar Lucknow

OWNER/Auth. Signature:-

Architect Signature:-

Dr. RAJNEESH KUMAR
B.Arch, MCA, IIA
CA201786849
RAGHAVA ARCHITECTS
Office:- 201, CS-09, GK-II, Indrapuram Ghaziabad (U.P.)
raghavaarchitects@gmail.com
9810379715, 9891146128