

PLOT NO-71 TO 76

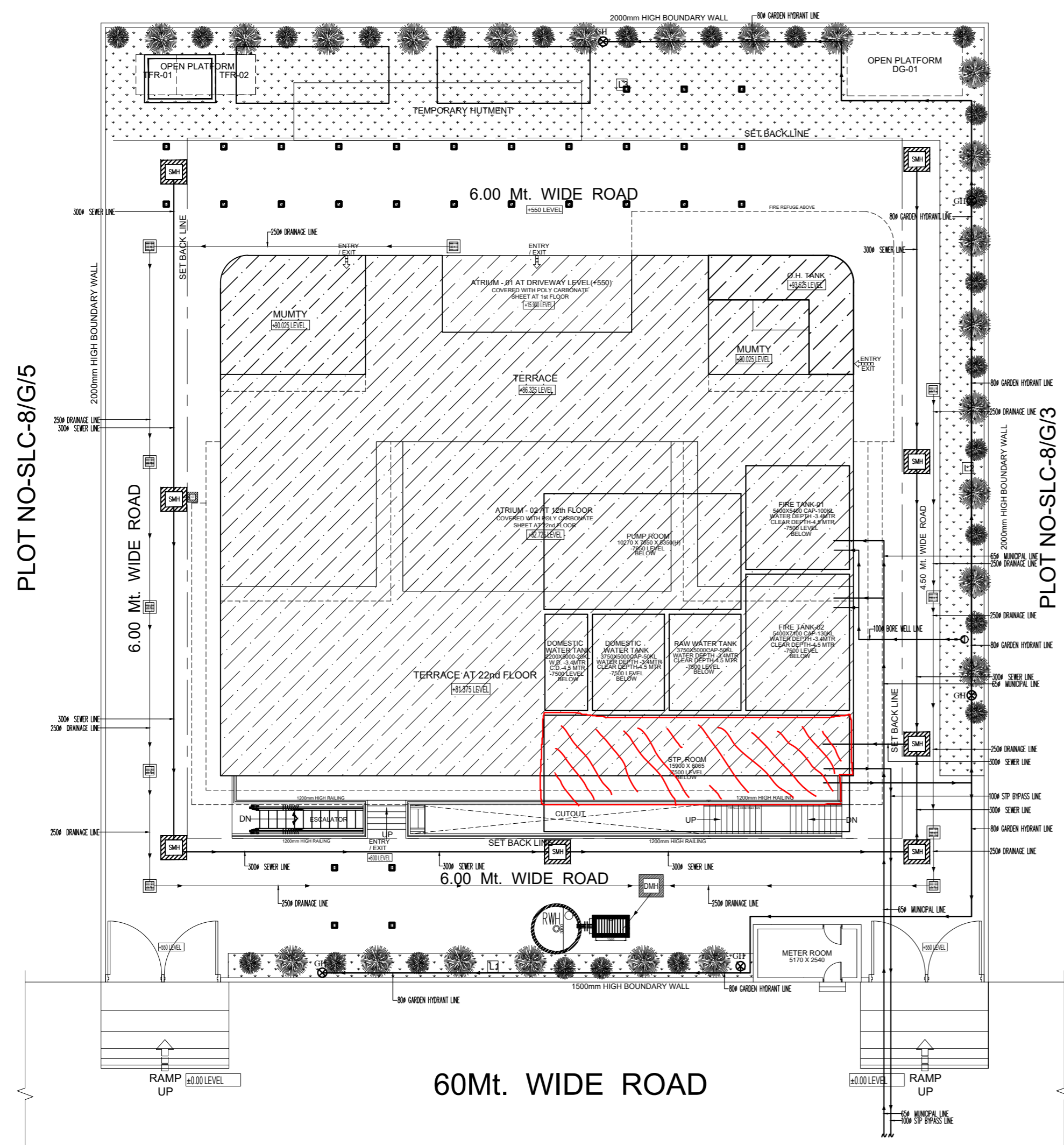

Rain Water Harvesting Calculations

As per Table No. 1 Rain Water Harvesting and Conservation Manual by CPWD, the annual rain fall is 1400 mm @ 45 mtr.

S.No	Description of Area	Area sqm.	Run-off Factor	Yearly Rainfall in mtr.	Volume of Water Available for Rain Water Harvesting Yearly (cum.)
1	Roof top areas	324.00	0.95	0.845	988.89
2	Roads and Pavements	1940.00	0.7	0.845	619.07
3	Green areas	349.00	0.7	0.845	207.41
Total					1492.29

Considering evaporation, spillage and first flush wastage, only 50% of water is actually available for rain water harvesting = 1193.83 m³

PEAK HOURLY RAINFALL = 60mm/hr

PEAK HOURLY DISCHARGE	
1	Roof Top
2	Roads and Pavements
3	Green areas
Total	

Average throughput for 250 mm dia harvesting bore well = 82.98 cum/hr

Retention tank for each pit (RWH SIZE - 3 mtr Dia and 3 mtr effective depth) = 20 cum

No. of pits required = 6.8 Nos

Say = 1.00 Nos

No. of pits Provided = 1 Nos

Water Requirement

S. No	Description	Unit/Area	Occupancy per unit (Person)	Total Occupancy	Water Requirement per capita per day (LPCD)	Total Requirement (lit)	Total Domestic Water Requirement (lit)	Total Fire Fighting Water Requirement (lit)
TOWER - I								
1	COVERED TERRACE (24x36)	612	35 (person)	3045	85	45855	1528	2087
2	UPPER FLOOR (24x36)	516	35 (person)	3620	85	45800	1837	2384
3	MIDDLE FLOOR (24x36)	540	35 (person)	3780	85	49500	2022	2726
4	GROUND FLOOR (24x36)	648	35 (person)	4524	85	49500	2222	2928
5	THIRD FLOOR (24x36)	648	35 (person)	4524	85	49500	2222	2928
6	12th NO. STOREY WITH 12th FLOOR & 20th FLOOR (ROOM)	120	2 (person/Room)	240	100	42000	2000	1600
7	20th FLOOR (ROOM)	84	35 (person)	2940	85	25000	1796	1524
8	ROOF TOP & BALCONY	1000				10000		
9	SPRINKLE STAIRS	100	45	4500	4500	27000	1800	
TOTAL						87000	47881	33120
1st No.						87000	47881	33120

Water requirement by according to AC Plant (100 TPD) = 28000

Volume of Flow (Q) = 1.12222 m³/sec

Hours of Operation - 24 Hrs

Average Daily Losses - 0.05

11. Backwash of Filter = 10000

Total = 112222

Capacity of Storage Treatment Plant = 77396

1.2% of Domestic Water = 1044

Planting Water = 171

1.2% of Domestic Water = 1044

Total = 112222

LEGEND OF PLUMBING

SYMBOL	DESCRIPTION
SMH	SEWER MANHOLE
DL	SEWER LINE
DL	DRAINAGE LINE
MH	DRAINAGE MANHOLE
CB	CATCH BASIN 450X450(TYP.)
ML	MUNICIPAL LINE
BWL	BORE WELL LINE
V	VALVE
STP	STP BYPASS LINE
GH	GARDEN HYDRANT LINE
GH	GARDEN HYDRANT

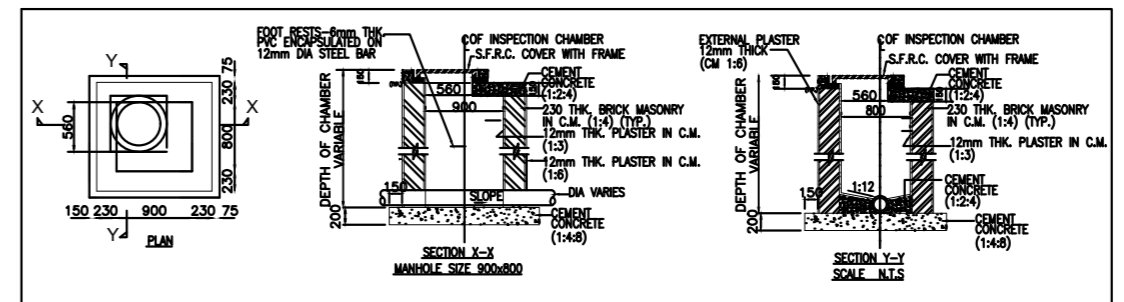
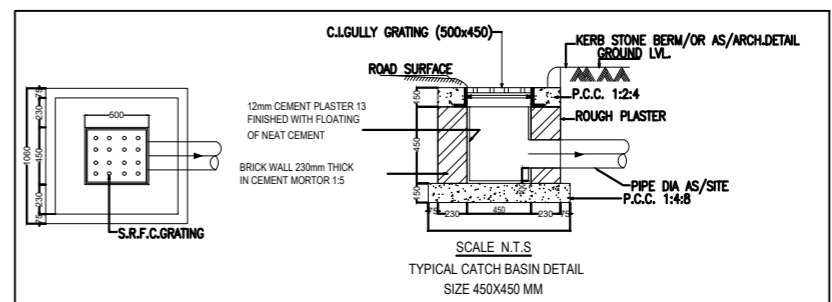
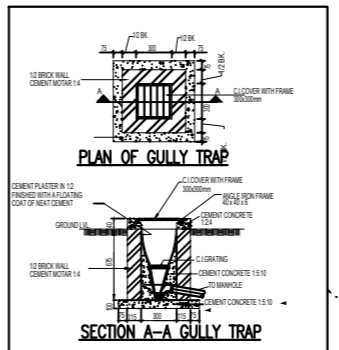
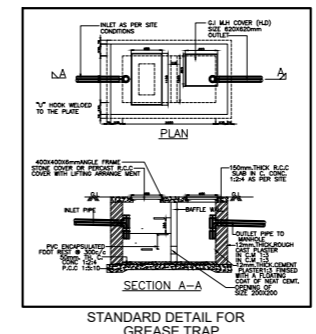
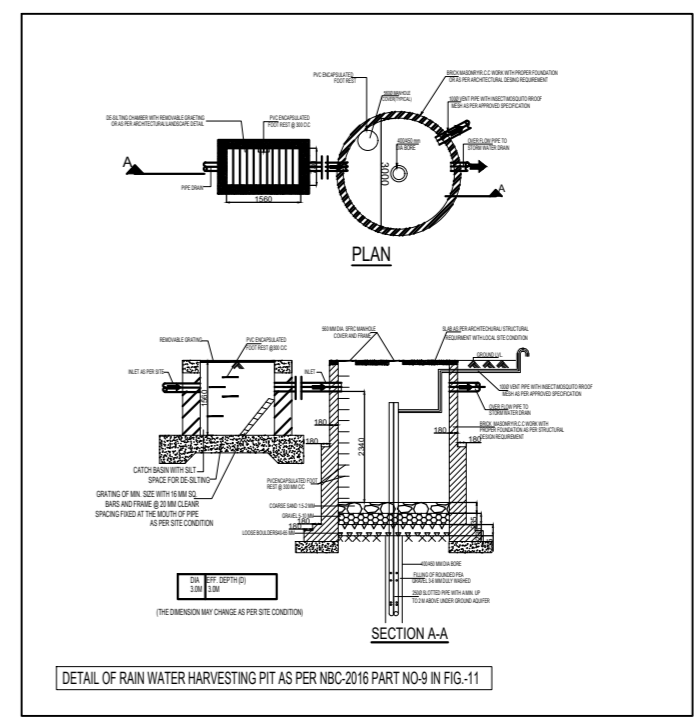

RAJESH VIJAYA
P. Raj Vijaya, Sector - 50, Noida
Chartered Engineer

For SUKADIV PROJECTS LLP
Authorised Signatory

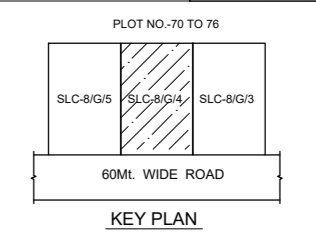

FOR SANCTION

PROJECT: PROPOSED COMMERCIAL COMPLEX "DIVYARV GRANDE" FOR SUKADIV PROJECTS LLP.
AT PLOT No. SLC-8/G/4, DELTA-II, GREATER NOIDA.

ARCHITECTS: plan india group
ARCHITECTURE, LANDSCAPE, INTERIOR DESIGN & PLANNING
A-80, RAIL NAGAR, SECTOR-50, NOIDA 201301
Mo. No. 98100-62882
email: planindiagroup@gmail.com

TITLE: SITE PLAN PLUMBING SUBMISSION DRAWING

DATE: 24/07/2025
PL-01A
DRG. NO.

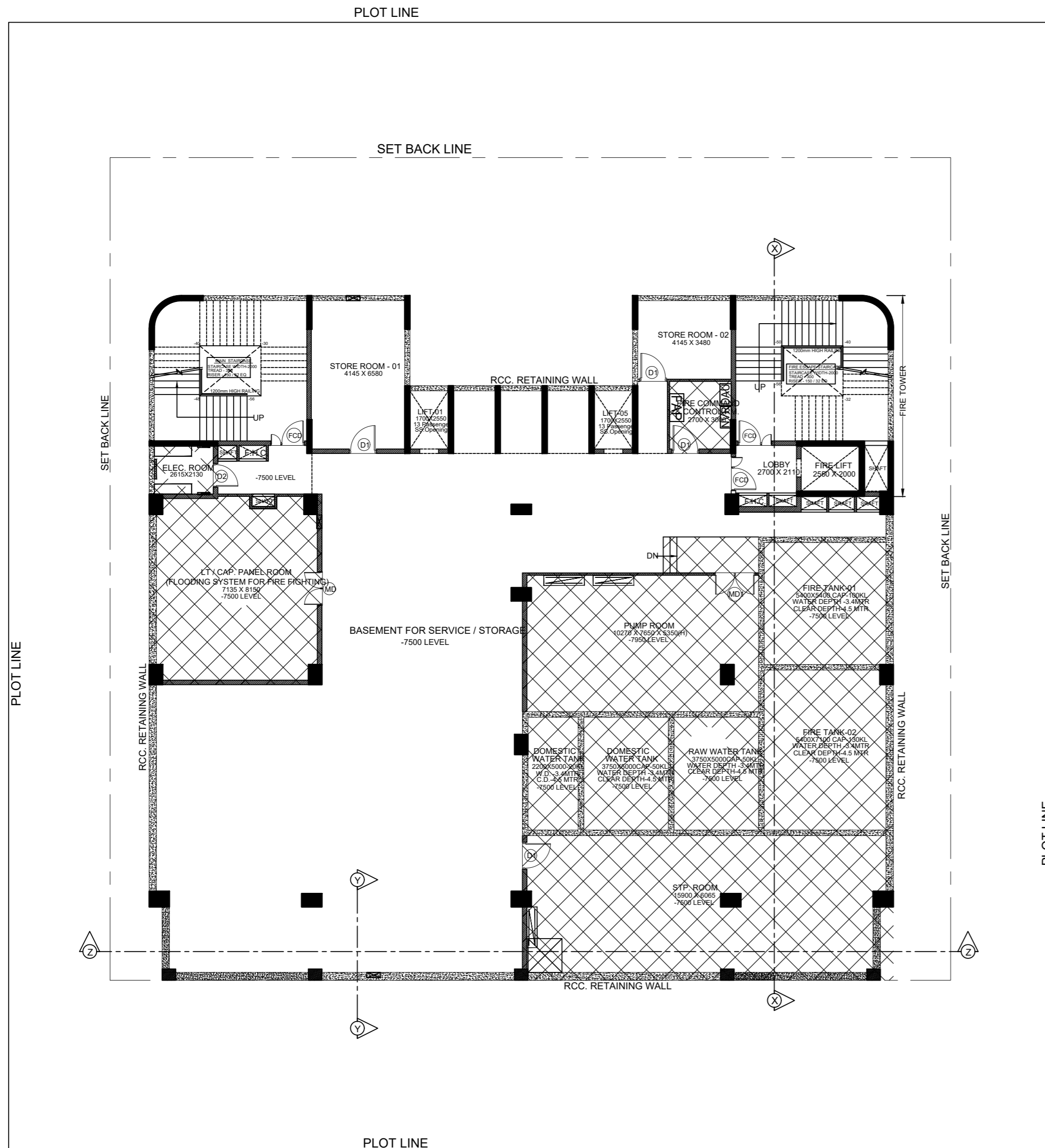

BASEMENT PLAN

Water Requirement									
S. No.	Description	Units/Area	Occupancy per unit (Person)	Total Occupancy	Water Requirement per capita per day (L/PCD)	Total Requirement (liters)	Total Domestic Water Requirement (liters)	Total Fire Water Requirement (liters)	Total Requirement (liters)
TD-WORK-1									
1	LOWER GROUND (SHOPS)	313	55person	304	15	4565	398	2987	7552
2	UPPER GROUND (SHOPS)	313	55person	306	15	4590	1007	2881	7471
3	FIRST FLOOR (SHOP)	343	55person	327	15	2152	622	1530	3682
4	SECOND FLOOR (SHOP)	343	55person	327	15	2152	622	1530	3682
5	THIRD FLOOR (SHOP)	343	55person	327	15	2152	622	1530	3682
6	13th-14th-15th-16th-18th-19th-20th FLOORS (ROOFS)	830	55person	313	25	7825	1888	1481	11194
7	22nd FLOOR (ROOFS)	454	55person	155	35	5425	3783	1024	10232
8	WATCHMEN LADENRY					1800			1800
9	SERVICE STAFFS			60	45	2700	2700	1800	7200
TOTAL						87835	47115	30130	87835
10) Water requirement by Addressing AC Plant (100 TR) LTR Consumption (including loss) - 1.5% Volume of Flow @ 4 L/SP/MINUTE Hours of Operation - 24 hrs. Average Daily Flowing - 180%									
11) Bore Well for Fire LTR 15000 65000 15228 82815 39333									
Capacity of Storage Treatment Plant 15% of Domestic Water = 30% of Flowing Water = 7788 LTR 15% of Fire Water = 11250 LTR = 15338 LTR = 15338 LTR = 15338 LTR									

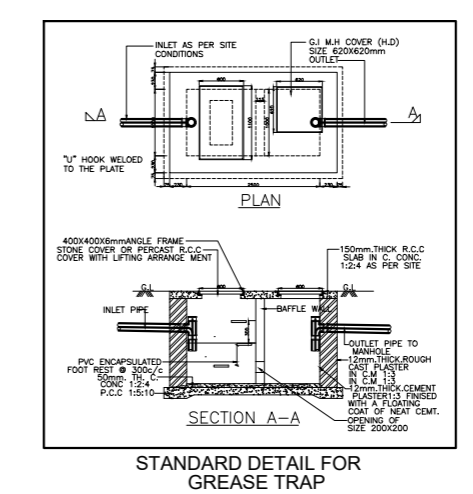
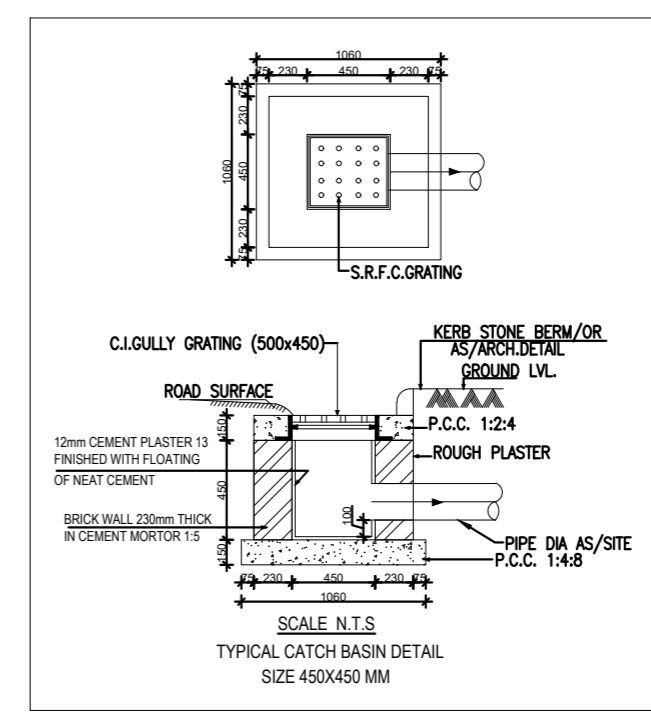

PLUMBING LEGEND:-	
①	110 OD SOIL PIPE
②	110 OD WASTE PIPE
③	160 OD SOIL PIPE
④	160 OD WASTE PIPE
⑤	COLD WATER SUPPLY PIPE (CWS)
⑥	FLUSHING WATER SUPPLY PIPE (FWS)
⑦	32* COLD WATER RISER PIPE (CWR)
⑧	32* FLUSHING WATER RISER PIPE (FWR)
⑨	160 OD RAIN WATER PIPE
FT	FLOOR TRAP
FD	FLOOR DRAIN

PLUMBING LEGEND:-	
—	SOIL PIPE LINE
—	WASTE PIPE LINE
(CWS)	COLD WATER SUPPLY
(FWS)	FLUSHING WATER SUPPLY
(HWS)	HOT WATER SUPPLY
—	CISTERN WITH ANGLE VALVE
HF	HEALTH FAUCET
∇	VALVE
●	GEYSER

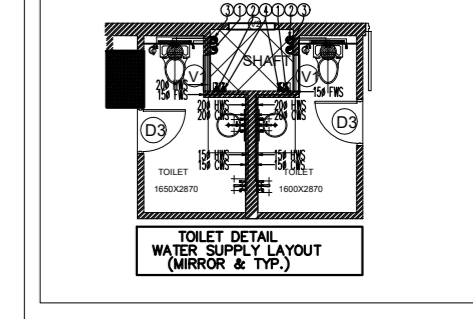
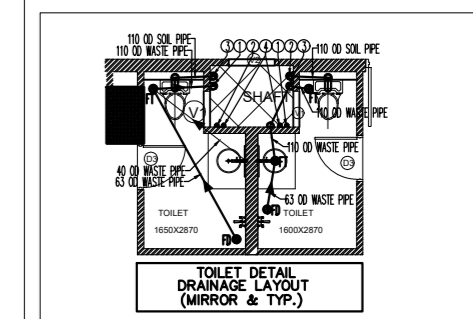
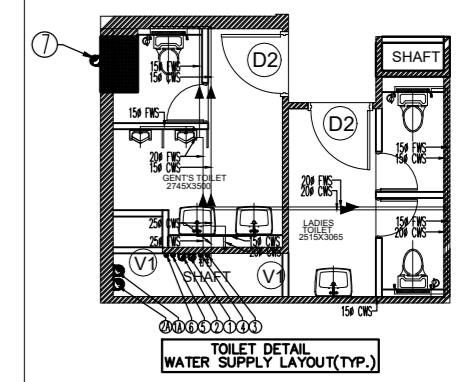
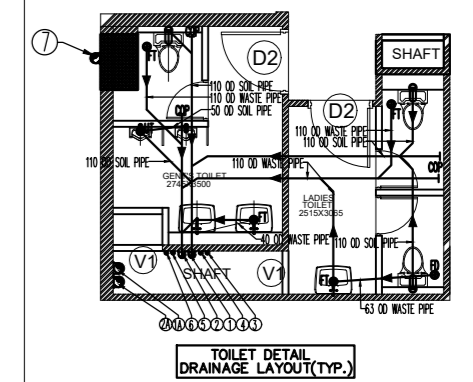

RAJESH VERMA
 ARCHITECT
 51, Rail Vihar, Sector-33, Noida.
 GATEWAY
 For SUKADIV PROJECTS LLP
 Authorised Signatory

- ▨ F.A.R. AREA
- ▨ NON F.A.R. AREA
- ▨ 15% SERVICE AREA

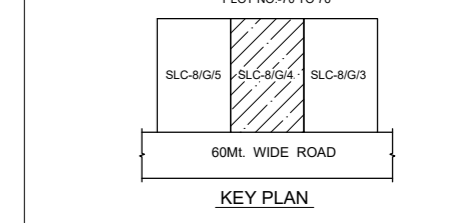

FOR SANCTION
 PROJECT:- PROPOSED COMMERCIAL COMPLEX "DIVYARV GRANDE" FOR SUKADIV PROJECTS LLP.
 AT PLOT NO. SLC-8/G4, DELTA-II, GREATER NOIDA.

ARCHITECTS:- **plan india group**
 ARCHITECTURE, LANDSCAPE, INTERIOR DESIGN, & PLANNING
 A-80, RAIL NAGAR, SECTOR-50, NOIDA 201301
 Mr. No. 98100-62282
 email - planindia@rediffmail.com

TITLE:- **BASEMENT PLAN PLUMBING SUBMISSION DRAWING**
 24/07/2025 PL-01
 DATE DRG. NO.



14th FLOOR PLAN

S. No.	Description	Unit/Area Sqm	Occupancy per Unit (Persons)	Total Occupancy	Water Requirement per capita per day (L/PCD)	Total Requirement (lit)	Total Domestic Water Requirement (lit)	Total Flushing Water Requirement (lit)	
TOWER - 1									
1	10th FLOOR (SHOPS)	215	35/person	354	15	4955	1269	2686	
2	10th FLOOR (OFFICES)	215	35/person	246	15	4955	1007	2948	
3	10th FLOOR (OFFICES)	343	35/person	827	15	23203	622	15581	
4	10th FLOOR (OFFICES)	343	35/person	827	15	23203	622	15581	
5	10th FLOOR (OFFICES)	343	35/person	827	15	23203	622	15581	
6	10th FLOOR (OFFICES)	343	35/person	827	15	23203	622	15581	
7	10th FLOOR (OFFICES)	343	35/person	827	15	23203	622	15581	
8	10th FLOOR (OFFICES)	343	35/person	827	15	23203	622	15581	
9	10th FLOOR (OFFICES)	343	35/person	827	15	23203	622	15581	
10	10th FLOOR (OFFICES)	343	35/person	827	15	23203	622	15581	
11	10th FLOOR (OFFICES)	343	35/person	827	15	23203	622	15581	
12	10th FLOOR (OFFICES)	343	35/person	827	15	23203	622	15581	
13	10th FLOOR (OFFICES)	343	35/person	827	15	23203	622	15581	
14	10th FLOOR (OFFICES)	343	35/person	827	15	23203	622	15581	
15	10th FLOOR (OFFICES)	343	35/person	827	15	23203	622	15581	
16	10th FLOOR (OFFICES)	343	35/person	827	15	23203	622	15581	
17	10th FLOOR (OFFICES)	343	35/person	827	15	23203	622	15581	
18	10th FLOOR (OFFICES)	343	35/person	827	15	23203	622	15581	
19	10th FLOOR (OFFICES)	343	35/person	827	15	23203	622	15581	
20	10th FLOOR (OFFICES)	343	35/person	827	15	23203	622	15581	
21	10th FLOOR (OFFICES)	343	35/person	827	15	23203	622	15581	
22	10th FLOOR (OFFICES)	343	35/person	827	15	23203	622	15581	
23	10th FLOOR (OFFICES)	343	35/person	827	15	23203	622	15581	
24	10th FLOOR (OFFICES)	343	35/person	827	15	23203	622	15581	
25	10th FLOOR (OFFICES)	343	35/person	827	15	23203	622	15581	
26	10th FLOOR (OFFICES)	343	35/person	827	15	23203	622	15581	
27	10th FLOOR (OFFICES)	343	35/person	827	15	23203	622	15581	
28	10th FLOOR (OFFICES)	343	35/person	827	15	23203	622	15581	
29	10th FLOOR (OFFICES)	343	35/person	827	15	23203	622	15581	
30	10th FLOOR (OFFICES)	343	35/person	827	15	23203	622	15581	
31	10th FLOOR (OFFICES)	343	35/person	827	15	23203	622	15581	
32	10th FLOOR (OFFICES)	343	35/person	827	15	23203	622	15581	
33	10th FLOOR (OFFICES)	343	35/person	827	15	23203	622	15581	
34	10th FLOOR (OFFICES)	343	35/person	827	15	23203	622	15581	
35	10th FLOOR (OFFICES)	343	35/person	827	15	23203	622	15581	
36	10th FLOOR (OFFICES)	343	35/person	827	15	23203	622	15581	
37	10th FLOOR (OFFICES)	343	35/person	827	15	23203	622	15581	
38	10th FLOOR (OFFICES)	343	35/person	827	15	23203	622	15581	
39	10th FLOOR (OFFICES)	343	35/person	827	15	23203	622	15581	
40	10th FLOOR (OFFICES)	343	35/person	827	15	23203	622	15581	
41	10th FLOOR (OFFICES)	343	35/person	827	15	23203	622	15581	
42	10th FLOOR (OFFICES)	343	35/person	827	15	23203	622	15581	
43	10th FLOOR (OFFICES)	343	35/person	827	15	23203	622	15581	
44	10th FLOOR (OFFICES)	343	35/person	827	15	23203	622	15581	
45	10th FLOOR (OFFICES)	343	35/person	827	15	23203	622	15581	
46	10th FLOOR (OFFICES)	343	35/person	827	15	23203	622	15581	
47	10th FLOOR (OFFICES)	343	35/person	827	15	23203	622	15581	
48	10th FLOOR (OFFICES)	343	35/person	827	15	23203	622	15581	
49	10th FLOOR (OFFICES)	343	35/person	827	15	23203	622	15581	
50	10th FLOOR (OFFICES)	343	35/person	827	15	23203	622	15581	
51	10th FLOOR (OFFICES)	343	35/person	827	15	23203	622	15581	
52	10th FLOOR (OFFICES)	343	35/person	827	15	23203	622	15581	
53	10th FLOOR (OFFICES)	343	35/person	827	15	23203	622	15581	
54	10th FLOOR (OFFICES)	343	35/person	827	15	23203	622	15581	
55	10th FLOOR (OFFICES)	343	35/person	827	15	23203	622	15581	
56	10th FLOOR (OFFICES)	343	35/person	827	15	23203	622	15581	
57	10th FLOOR (OFFICES)	343	35/person	827	15	23203	622	15581	
58	10th FLOOR (OFFICES)	343	35/person	827	15	23203	622	15581	
59	10th FLOOR (OFFICES)	343	35/person	827	15	23203	622	15581	
60	10th FLOOR (OFFICES)	343	35/person	827	15	23203	622	15581	
61	10th FLOOR (OFFICES)	343	35/person	827	15	23203	622	15581	
62	10th FLOOR (OFFICES)	343	35/person	827	15	23203	622	15581	
63	10th FLOOR (OFFICES)	343	35/person	827	15	23203	622	15581	
64	10th FLOOR (OFFICES)	343	35/person	827	15	23203	622	15581	
65	10th FLOOR (OFFICES)	343	35/person	827	15	23203	622	15581	
66	10th FLOOR (OFFICES)	343	35/person	827	15	23203	622	15581	
67	10th FLOOR (OFFICES)	343	35/person	827	15	23203	622	15581	
68	10th FLOOR (OFFICES)	343	35/person	827	15	23203	622	15581	
69	10th FLOOR (OFFICES)	343	35/person	827	15	23203	622	15581	
70	10th FLOOR (OFFICES)	343	35/person	827	15	23203	622	15581	
71	10th FLOOR (OFFICES)	343	35/person	827	15	23203	622	15581	
72	10th FLOOR (OFFICES)	343	35/person	827	15	23203	622	15581	
73	10th FLOOR (OFFICES)	343	35/person	827	15	23203	622	15581	
74	10th FLOOR (OFFICES)	343	35/person	827	15	23203	622	15581	
75	10th FLOOR (OFFICES)	343	35/person	827	15	23203	622	15581	
76	10th FLOOR (OFFICES)	343	35/person	827	15	23203	622	15581	
77	10th FLOOR (OFFICES)	343	35/person	827	15	23203	622	15581	
78	10th FLOOR (OFFICES)	343	35/person	827	15	23203	622	15581	
79	10th FLOOR (OFFICES)	343	35/person	827	15	23203	622	15581	
80	10th FLOOR (OFFICES)	343	35/person	827	15	23203	622	15581	
81	10th FLOOR (OFFICES)	343	35/person	827	15	23203	622	15581	
82	10th FLOOR (OFFICES)	343	35/person	827	15	23203	622	15581	
83	10th FLOOR (OFFICES)	343	35/person	827	15	23203	622	15581	
84	10th FLOOR (OFFICES)	343	35/person	827	15	23203	622	15581	
85	10th FLOOR (OFFICES)	343	35/person	827	15	23203	622	15581	
86	10th FLOOR (OFFICES)	343	35/person	827	15	23203	622	15581	
87	10th FLOOR (OFFICES)	343	35/person	827	15	23203	622	15581	
88	10th FLOOR (OFFICES)	343	35/person	827	15	23203	622	15581	
89	10th FLOOR (OFFICES)	343	35/person	827	15	23203	622	15581	
90	10th FLOOR (OFFICES)	343	35/person	827	15	23203	622	15581	
91	10th FLOOR (OFFICES)	343	35/person	827	15	23203	622	15581	
92	10th FLOOR (OFFICES)	343	35/person	827	15	23203	622	15581	
93	10th FLOOR (OFFICES)	343	35/person	827	15	23203	622	15581	
94	10th FLOOR (OFFICES)	343	35/person	827	15	23203	622	15581	
95	10th FLOOR (OFFICES)	343	35/person	827	15	23203	622	15581	
96	10th FLOOR (OFFICES)	343	35/person	827	15	23203	622	15581	
97	10th FLOOR (OFFICES)	343	35/person	827	15	23203	622	15581	
98	10th FLOOR (OFFICES)	343	35/person	827	15	23203	622	15581	
99	10th FLOOR (OFFICES)	343	35/person	827	15	23203	622	15581	
100	10th FLOOR (OFFICES)	343	35/person	827	15	23203	622	15581	

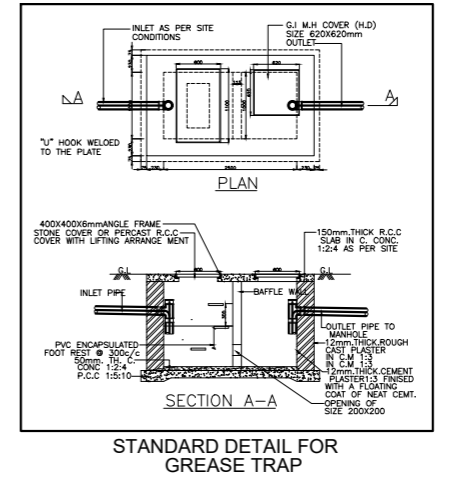
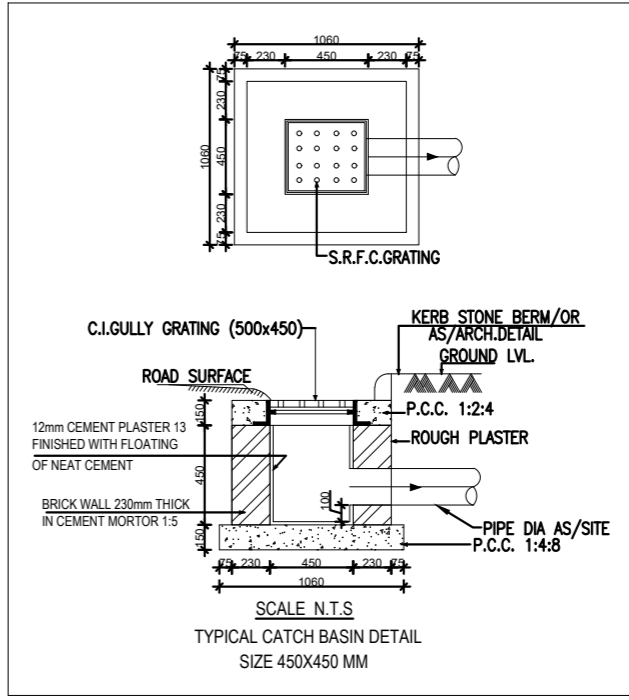

S.NO.	SYMBOL	DESCRIPTION
1	●	110 OD SOIL PIPE
2	●	110 OD WASTE PIPE
3	●	160 OD SOIL PIPE
4	●	160 OD WASTE PIPE
5	●	COLD WATER SUPPLY PIPE (CWS)
6	●	FLUSHING WATER SUPPLY PIPE (FWS)
7	●	32# COLD WATER RISER PIPE (CWR)
8	●	32# FLUSHING WATER RISER PIPE (FWR)
9	●	160 OD RAIN WATER PIPE
10	●	FLOOR TRAP
11	●	FLOOR DRAIN

S.NO.	SYMBOL	DESCRIPTION
1	—	SOIL PIPE LINE
2	—	WASTE PIPE LINE
3	(CWS)	COLD WATER SUPPLY
4	(FWS)	FLUSHING WATER SUPPLY
5	(HWS)	HOT WATER SUPPLY
6	—	CISTERN WITH ANGLE VALVE
7	HF	HEALTH FAUCET
8	∇	VALVE
9	●	GEYSER

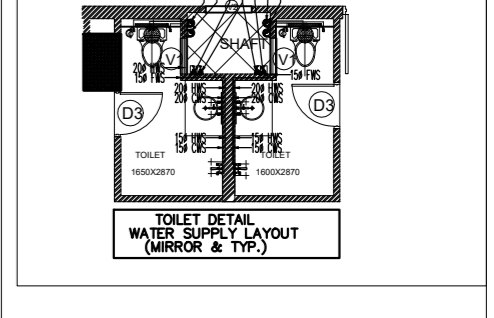
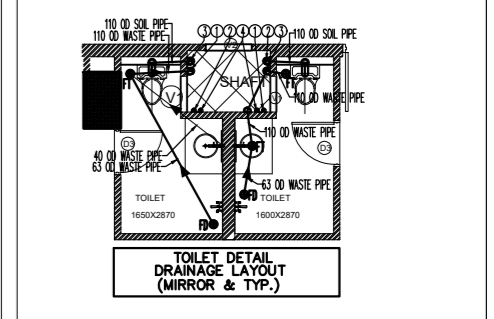
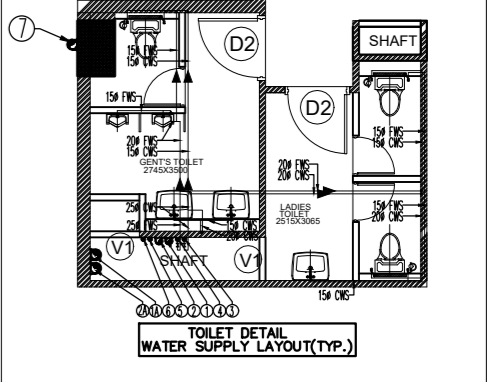
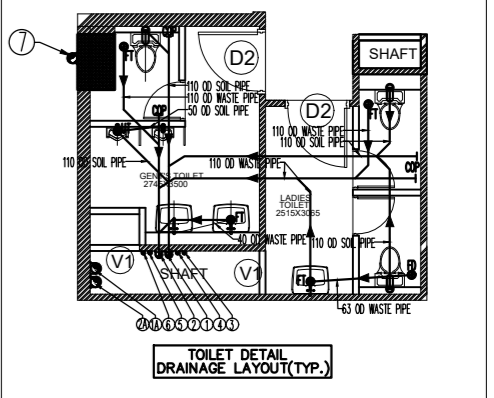

RAJESH VERMA
Architect
51, Rail Vihar, Sector - 33, Noida.
GATEWAY

For SUKADIV PROJECTS LLP
(Signature)
Authorised Signatory

- ▨ F.A.R. AREA
- ▨ NON F.A.R. AREA
- ▨ 15% SERVICE AREA

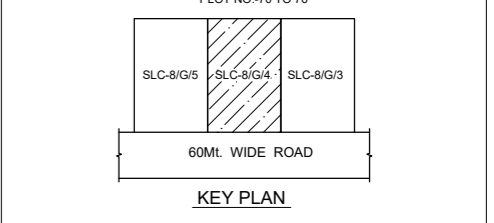

FOR SANCTION

PROJECT: PROPOSED COMMERCIAL COMPLEX "DIVYARV GRANDE" FOR SUKADIV PROJECTS LLP.
AT PLOT NO. SLC-8/G/4, DELTA-II, GREATER NOIDA.

ARCHITECTS: **plan india group**
ARCHITECTURE, LANDSCAPE, INTERIOR DESIGN, & PLANNING
A-80, RAIL NAGAR, SECTOR-50, NOIDA 201301
Mo. No. 98100-62882
email: planindia@rediffmail.com

14th FLOOR PLAN		
PLUMBING SUBMISSION DRAWING		
24/07/2025	PL-11	
DATE	DRG. NO.	