

LEGEND :-

S.No.	DESCRIPTION	SYMBOL
1.	SEWERAGE LINE	
2.	STORM WATER DRAINAGE LINE	
3.	DOMESTIC WATER RISER PIPE	
4.	FLUSHING WATER RISER PIPE	
5.	INSPECTION CHAMBER SIZE 600X600MM	
6.	CATCH BASIN SIZE 450X450MM	
7.	SEWER CIRCULAR MANHOLE	
8.	STORM WATER CIRCULAR MANHOLE	

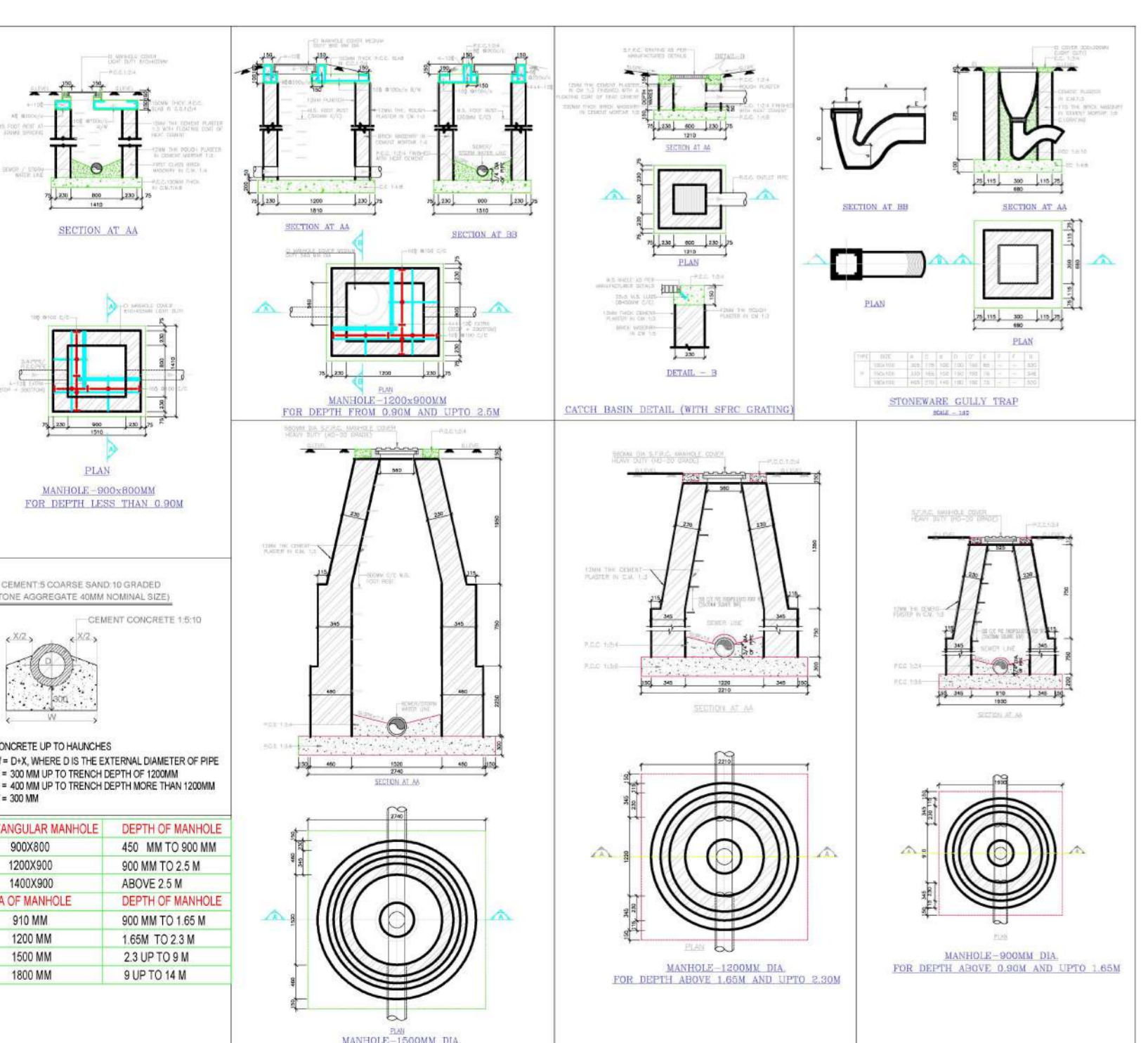
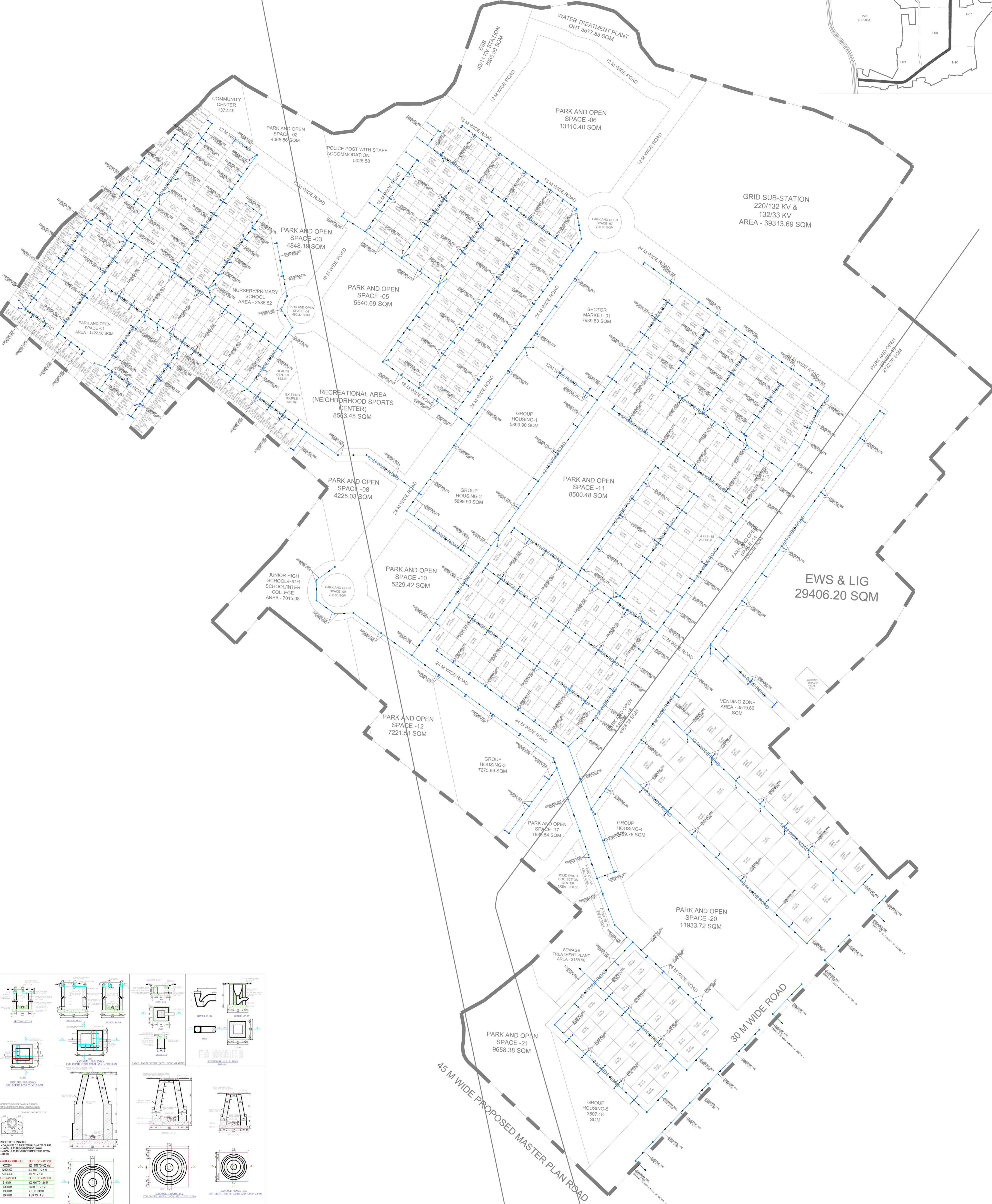
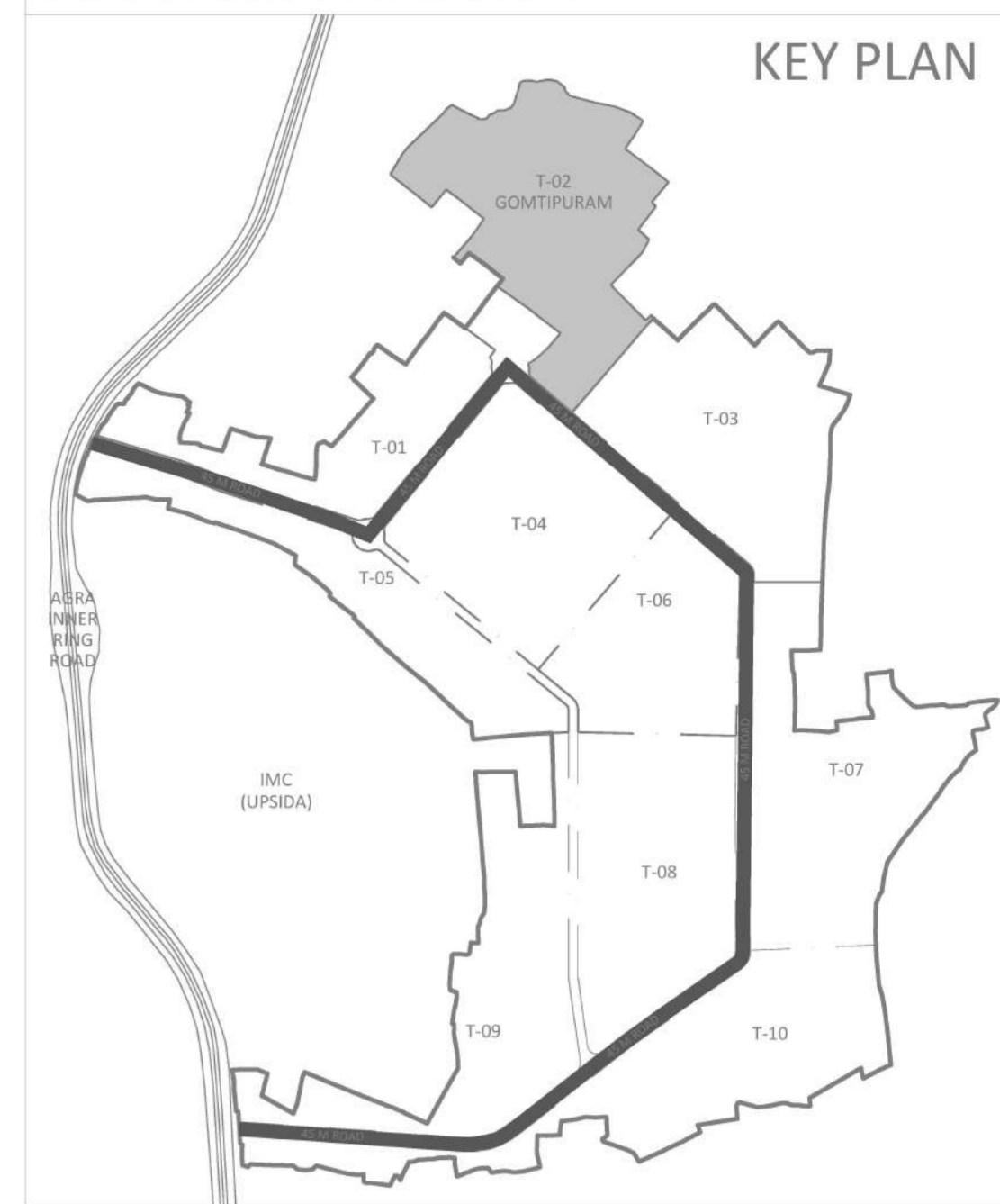

Agra Development Authority ADA
Ratan Muni Road, Jaipur House Colony
Agra, Uttar Pradesh - 282010

DDF Consultants Pvt. Ltd
501, B-9, ITL Twin Towers, Netaji Subhash Place, Pitampura, New Delhi-110034
Phone: 011-47400500 (100 lines) Fax: 011-47400555

SAHIL KATYAL
Sahil Katyal
(Architect & Urban Planner)

AKSHAY GAUR
Akshay Gaur
(Architect & Urban Planner)

PROJECT TITLE: PROPOSED LAYOUT PLAN OF GOMTIPURAM TOWNSHIP ON KHASRA NO. (23-36, 41-58, 48(HT), 75-99, 102-106, 108-109, 281-282, 287-295, 304-305) OF VILLAGE RAHANKALAN, AGRA, UTTAR PRADESH

DRAWING TITLE: PROPOSED SEWER LAYOUT PLAN

SHEET NO. : 3/8

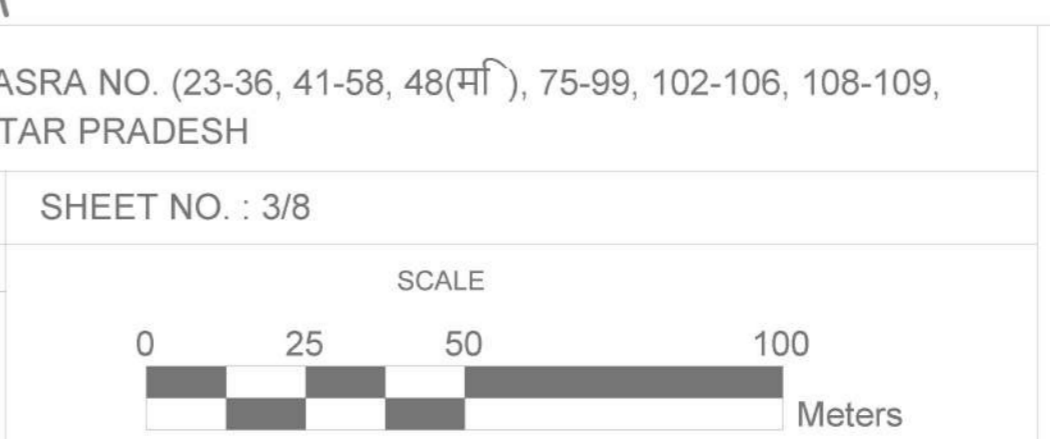

DRAGONS
DRAFTSMAN: J.E., A.E.

T.P.
SECRETARY: T.P., VICE CHAIRMAN: H.A.