

SANITATION DETAIL FOR GROUND FLOOR

PLAN OF RAIN WATER HARVESTING

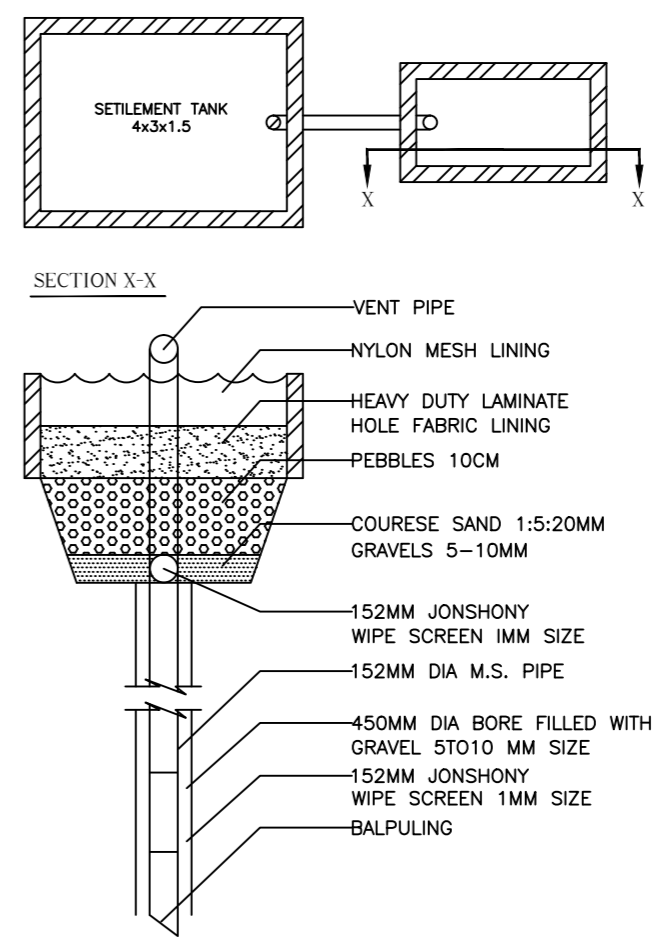

PLAN OF RAIN WATER HARVESTING (NOT TO SCALE)

AREA STATEMENT						
TYPE OF FLAT	FLOOR	FLAT AREA IN SQM.	NO. OF FLATS ON G.F.	NO. OF FLATS ON F.F.	NO. OF FLATS ON S.F.	TOTAL NO. OF ON G+2
1-BHK	G+2	52.70	03	03	03	9 NOS.
2-BHK TYPE-A	G+2	78.50	07	07	07	21 NOS.
2-BHK TYPE-B	G+2	105.00	02	02	02	06 NOS.
TOTAL						36 NOS.

SPECIFICATIONS

- FIRST CLASS BRICK WORK IN 1:6 C/ MORTAR
- R.C.C. WORK IN 1:1.5:3 CEMENT MIX
- FOUNDATION CEMENT CONC. IN 1:4:8 MIX
- PLASTERING IN 1:6 CEMENT MORTAR
- DOOR WINDOW IN WOODEN WORK

TITLE -

SANITATION DETAIL FOR GROUND FLOOR

UNIT DETAIL

PERMISSIBLE UNIT - 36
ACHIEVED UNIT - 36

AREA STATEMENT	SQM.	%TAGE
1. TOTAL LAND AREA	3280.00	
2. OWNER'S LAND LEFT FOR ROAD WIDENING	361.60	
3. NET LAND AREA	2918.40	100.00
4. PROP.COVD.AREA ON G.F	1125.01	38.55
5. G.F OPEN AREA	1793.39	61.45
6. PROP.COVD.AREA ON F.F	1125.01	38.55
7. PROP.COVD.AREA ON S.F	1125.01	38.55
8. PROP.COVD.MUMTY AREA	107.12	03.67
9.TOTAL PROP.COVD.F.A.R AREA	3375.03	115.65
10. TOTAL PROP.(F.A.R+NON F.A.R AREA)	3482.15	
11. ACHIEVED F.A.R.	1.16	
12. PERMISSIBLE F.A.R.	1.20	
13. ACHIEVED COVERAGE	38.55%	
14. PERMISSIBLE COVERAGE	40%	
15. OPEN PARKING	805.00/23	35 Cars
16. ACHIEVED PARKING	35 Cars	
17. PERMISSIBLE PARKING	35 Cars	

PROPOSED PLAN OF THE GROUP HOUSING BUILDING ON KHASARA NO. -211,212 & 213 SITUATED AT MAUJA CHATIKARA TEH. & DISTT. MATHURA

OWNERS :-

BHAGVATI COAL MOVERS PVT. LTD.
A.G.-579 SHALIMAR BAG, NEW DELHI
AUTHORIZED REPRESENTATIVE
SHRI AKHIL KUMAR JAIN
S/O SHRI DEVENDRA KUMAR JAIN &
SHRI DEENA AGRAWAL
S/O LATE SHRI RADHA RAMAN AGRAWAL

OWNER'S SINGN :-

ARCHITECTS:

AN ISO 9001-2008 CERTIFIED COMPANY

BAJAJ CONSTRUCTIONS

Architects Engineers Structural Consultants
Interior Designers Valuer & PMC
A-8/7, KRISHNA NAGAR, MATHURA
PH. 7900204888
CELL. 9412280100.

Website : www.bajajconstructions.com
E-mail : bajaj_consts@rediffmail.com
bajajconstructions2@gmail.com